

# Information Systems

Hitachi aims to be your Best Solutions Partner on the basis of trust developed since its founding with product groups involving electricity, water supply, transportation and other such infrastructure that serves as a lifeline for the support of information systems. An indispensable condition for the coming ubiquitous information society is the ability to access information in a secure and safe manner anytime, anywhere and by anybody. We are therefore striving to realize a secure, safe and comfortable society through highly reliable and highly functional products and security solutions.



## Expanded Solutions for Electronic Government

The Japanese government is working toward the establishment of an electronic government by fiscal year 2003 through its "Millennium Project" and "e-Japan Strategy."

In response to this movement, Hitachi, Ltd. has added the following new and expanded solutions to provide total support for the digitization of government services.

### (1) Government Evaluation Solution

This solution supports the introduction and implementation of efficient government evaluation. It provides tools for assessing government activities objectively from a business point of view and for making effective improvements to those activities.

The Government Evaluation Solution is based on a government evaluation system (first marketed in April 2001) that was the first in Japan to employ corporate accounting techniques to estimate the total cost of government operations. It supports the establishment of local business-management methods that involve both residents and government through such services as information provision and opinion polls.

### (2) Document Management Solution

Japan's Information Disclosure Law enacted in April 2001 calls for quick response to applications received for the disclosure of documents held by government institutions. This gives more urgency to the digitization of paper documents that have been managed by conventional methods up to now.

For this reason, Hitachi's Document Management Solution consists of three key products. In addition to Information Provision System, there are Total Document Management System for digitizing documents at a prior stage and systematizing document management in government institutions, and e-mail Management System.

Among the above, e-mail Management System is the first e-mail management system in Japan to automatically classify daily sent and received e-mails by subject matter and store them in a database, and to allow for e-mail searching and retrieval. In this

way, e-mail Management System enables to record know-how and decision-making processes, suggesting novel ways of using e-mail.

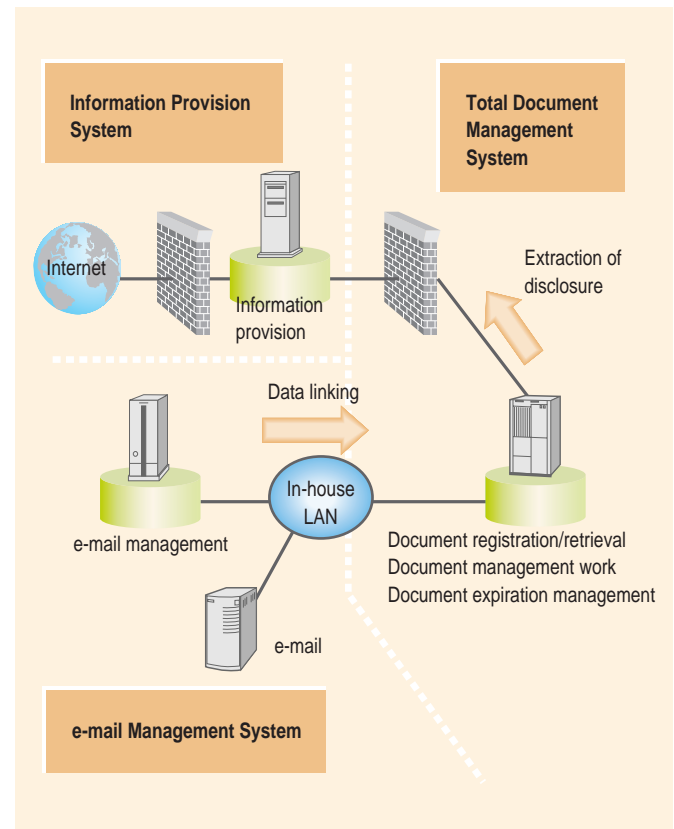

#### Concept of Document Management Solution

The Document Management Solution allows to realize central management of various kinds of government documents including e-mails. It supports effective use of past documentation and process of information disclosure.

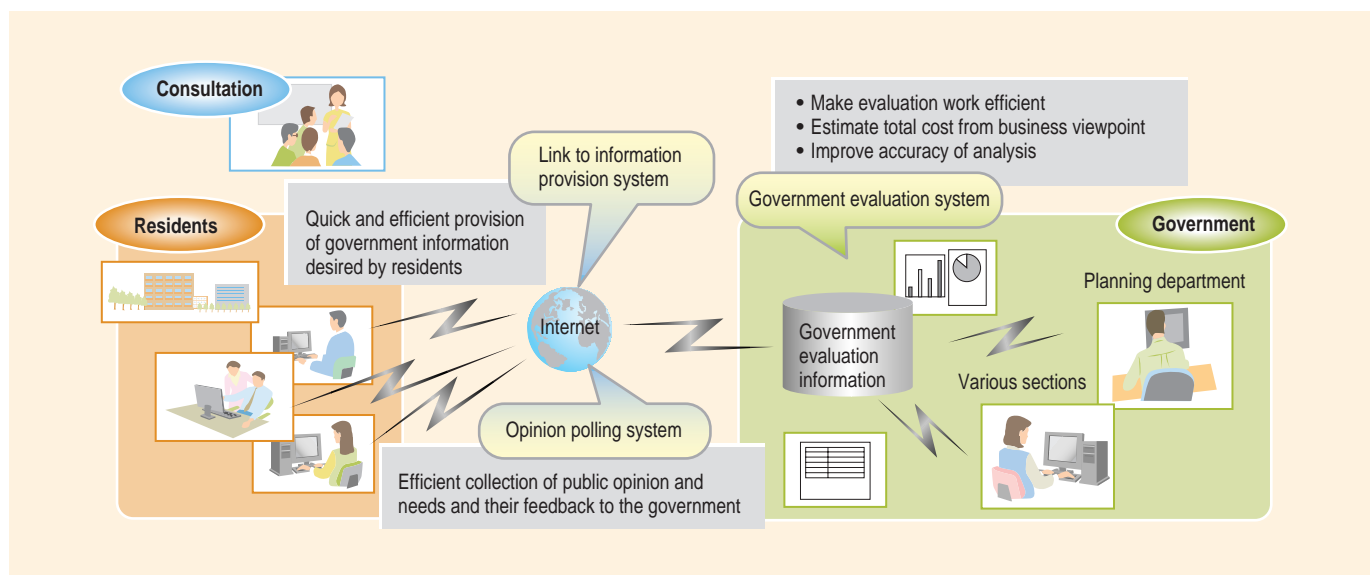

#### Typical application of Government Evaluation Solution

The Government Evaluation Solution supports effective government evaluation with thorough communication between residents and government through consultation and various tools centered on a government-evaluation system.

## Hitachi's IT Solutions for Manufacturing in the Internet Era

The IT industry is rapidly expanding on a world-wide scale throughout the world with the coming of the Internet era. This expansion and the Internet itself are transforming the structure of industries. For instance, M&A (mergers and acquisitions) and business cooperation are promoted globally so that many companies are coming to include electronics manufacturing services. Today, many managers have to run their businesses under severe conditions, such as meeting requirements for diverse products and coping with reduced product lifetimes.

Hitachi's IT solutions for manufacturing is to the several problems that management and business pose for customers in the manufacturing industry. They consist of solutions in seven categories that help the customer to rapidly and flexibly deal with the ever-changing market.

- (1) The e-market place
- (2) DE (digital engineering)
- (3) Ecology
- (4) CRM (customer-relationship management)
- (5) SCM (supply-chain management)
- (6) ERP (enterprise resource planing)

### (7) MES (manufacturing execution system)

Instances where collaboration and the integration of information systems on intra- and inter-company bases are seen as necessary have recently been increasing in number. This increase is related to the recent trend of M&A and cooperation between companies in other industries as well as in manufacturing industries. Hitachi's IT solutions for manufacturing are positive adaptations of new technologies to meet many kinds of demands.

Hitachi has also been providing a CPC (collaborative products commerce) service since May 2001. The CPC service realizes collaboration between companies as well as between the departments of a company by means of the reconsideration of business processes, and information. The CPC service contributes to the realization of total management and improvement of utility by use of the portal software. In particular, the CPC service deals with the collaboration between the links in the supply chain and in the engineering chain in manufacturing industries.

Hitachi will continue to provide new solutions to meet the new demands of manufacturing industry .

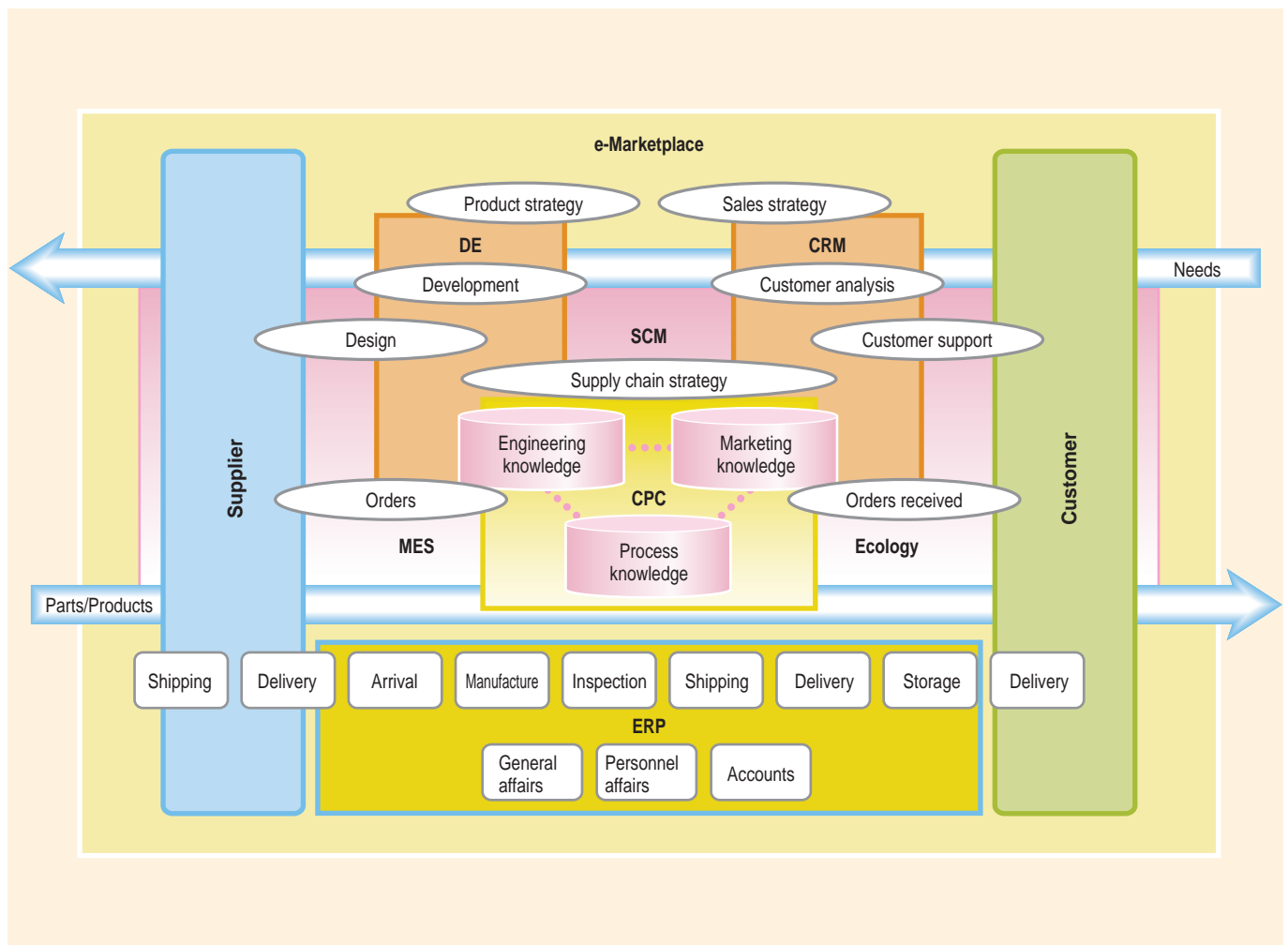

*Hitachi's IT solutions for manufacturing*

*Solutions support the construction of strategic information systems through the mutual collaboration.*

## TWX-21 Improves the Efficiency of the Work Across the Whole Range of Corporate Activity

The develop of the eMP (electronic marketplace) originated in the U.S.A. but has become a major trend in many other countries; E2open (for the electronics sector) and Transora (for retailers) in the U.S.A. and ISB2B for sourcing information of vendors in China. These eMPs are managed by the multiple buyers and suppliers. Another type of eMP is the private eMP, which is purely for the purpose of private SCM development.

An eMP is not restricted to providing the user with procurement functionality but may be made applicable to almost all processes of an enterprise and can be used for possible areas of application including design, sourcing, and so on.

User companies are able to maximize their functions of procurement and sales by using the services of eMPs in various business. Business processes will move seamlessly from design to sales, so that linkage with multiple eMPs including in-house systems will also be important. Such linkage has been eased by the advent of XML (extensible markup language). When we consider the overall management workload, including trouble shooting and the setting of maintenance rules, we see that the management will be a heavy job for the user.

TWX-21, which entered service in 1997 and has become a

major B2B business-media service in Japan, has over 12,000 users. Users compete in selling commodities to their customers. In producing these commodities, they apply the services of TWX-21 for collaboration in design, procurement, production. Once a user has joined TWX-21, the user does not have to face complex tasks of system connection or configuration.

TWX-21 provides a common platform where linkage with E2open or some other eMP is achieved by a single connection. TWX-21's CPFR (collaborative planning and replenishment) service enables users to upgrade their levels of sales activity. The system provides a standard platform on which retailers and vendor exchange current information about actual sales and forecasts of sales, sales-promotion plans, current levels of stock, so that a user is able to minimize its inventory of stock. This service allows the user company to cooperate with its partners in taking various factors into account to obtain accurate sales figures.

Furthermore, TWX-21 offers support for the development of private eMPs as a service for its customers. This is suitable for those customers who have their own business procedures to which the standard services are not applicable.

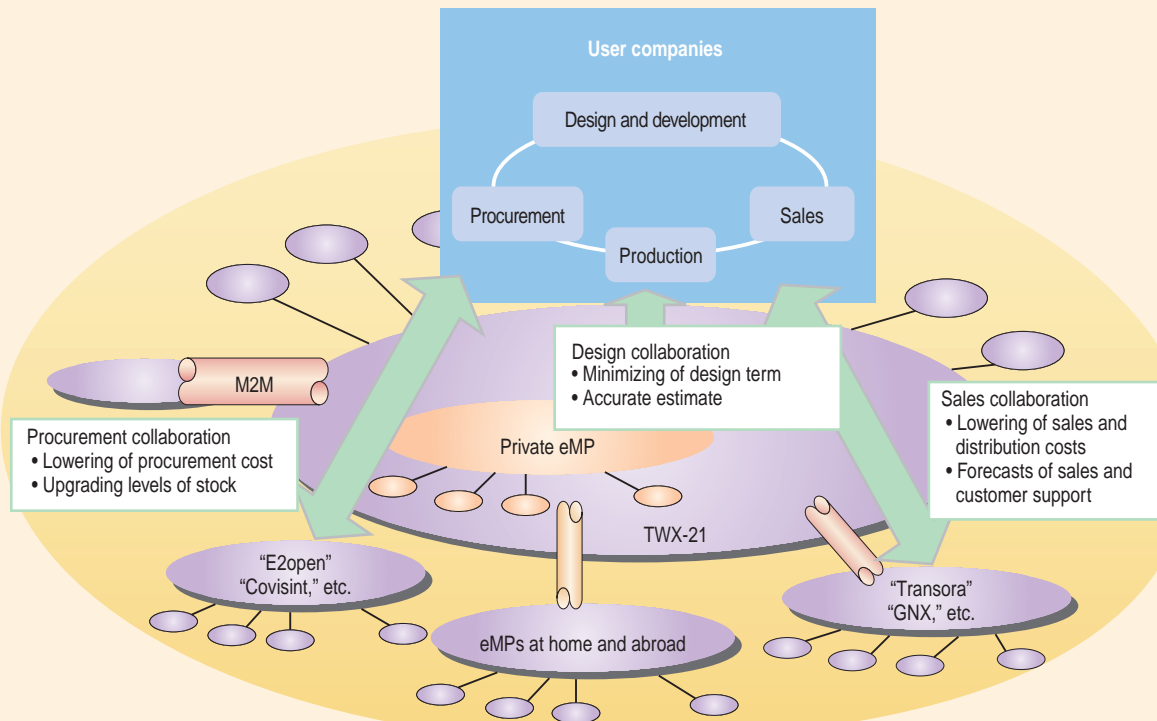

*TWX-21: Facilitating collaboration between companies by linking eMPs*  
 Linking domestic and overseas eMPs makes it easy for companies to collaborate in design, production, procurement, sales, distribution, and other activities. TWX-21 improves the efficiency work across the whole range of corporate activity, i.e., including those which involve customers, clients, suppliers, etc.

## Job Management Partner 1 Version 6i: Integrated Solutions for Improving Customer Services in an E-business Environment

The increasing popularity and capabilities of broadband and mobile devices have led to strong diversity in the range of Internet-connected environments. This has in turn placed stricter requirements in terms of quality and stability on e-business environments. In order to fulfill these requirements, providers must construct highly reliable system-operating environments on the Internet and must reduce costs by efficiently operating these environments. The software products that make up Job Management Partner 1 were developed as tools for use in the construction of corporate information systems that support e-business.

Version 6i of Job Management Partner 1 (abbreviated below as Version 6j) extends and strengthens the advanced reliability, productivity and operability features that were provided by previous versions of the Job Management Partner 1 software. Version 6i aims at *Internet Service Quality Management* to provide high quality services in a global business environment. Version 6i in the operational management of customers' corporate information systems based on three key concepts: *Serviceability, Service Security and Service Cost*.

Job Management Partner 1 is currently deployed in more than 6,000 corporations both in Japan and abroad. This industry-leading software for system management is highly rated by its users. Job Management Partner 1 is extremely flexible and supports a wide range of business activities, including enterprise resource planning (ERP), the operation of data warehouses (DWH), and the provision of Web-computing solutions.

The major new features of Version 6i are:

### (1) Enhanced network management facilities

• Support for IPv6 (version 6 of the Internet Protocol) network environments. The new version leads other vendors in the network-management industry. Version 6i supports Hitachi's gigabit router devices as well as other IPv6-supported devices, providing for the configuration management, fault management and performance management of such devices. Version 6i provides for the integrated management of mixed environments which

contain both IPv4 and IPv6 networks, and thus provides a way of managing newly constructed IPv6 network environments without requiring changes to the existing IPv4 network environments.

### (2) Enhanced integrated security management

• The integrated security-management functions of Version 6i provide for the central management of various security products, including, of course, products from other vendors. The setup definitions for the managed security products within the system's domain are centrally managed, security-related events are monitored across the system as a whole, and the administrators notified when specified events occur. Version 6i also provides information that assists in security audits. The information is based on the assembled logs of the activities of the system's security products.

• Version 6i provides file access control functions that monitor all file accesses and permit access (read/write) for specified users and programs only. The functions enable robust security management.

### (3) Enhanced availability management

• Version 6i provides availability management solutions for multi-platform environments. Version 6i is thus capable of managing the performance and availability of the operating systems and of applications such as ERP, databases, groupware, and middleware in a mixed UNIX\* / Windows\*\* environment.

Ubiquitous-computing environments are expected to develop, bringing computational equipment into a yet closer connection with our lives. 'The advent of so-called "information appliances" represents a step in this direction.' Job Management Partner 1 provides rapid and flexible support for system environments of this type. Our aim is to place Job Management Partner 1 as the de facto standard for the system-management software that sustains the corporate information systems of the 21st century.

\* UNIX is a registered trademark in the United States and other countries, licensed exclusively through X/Open Company Limited.

\*\* Windows is a registered trademark of Microsoft Corp. in the U.S. and other countries.

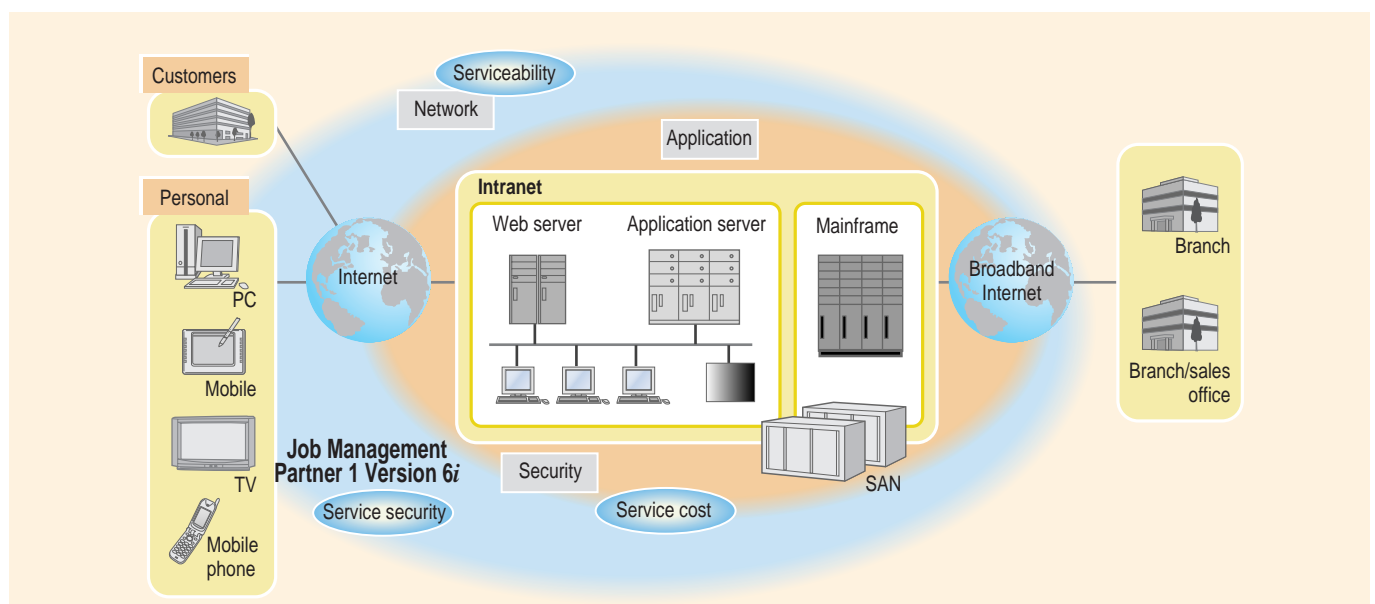

Concept of Job Management Partner 1 Version 6i

## Occupation-oriented Financial Solutions “Hitachi Financial Community”

In corporations, there is a need for programs that educate employees on asset management and for reduction of welfare expenses, etc. With the advent of the fixed contribution pension, etc., we have entered the era of employees taking responsibility for managing their own assets.

In the Hitachi Group, the Hitachi Financial Community (HFC), a portal service that provides excellent one-stop financial services, was started in April 2001. By using HFC, it is possible to introduce services ranging from the procedures of financial organizations to the provision of financial information efficiently in the form of a coherent portal for employees. Employees can obtain accurate information from financial organizations that cooperate with HFC as well as quality financial products.

On the other hand, financial organizations that have contracted with HFC can obtain market information that is specific to occupations, so the development and provision of products that are suited to a particular occupation are easy to accomplish. Furthermore, an occupation is a homogeneous market for financial organizations.

With Hitachi’s background in network technology and security technology, we have formed stable ties between financial service enterprises within the Hitachi Group, such as Hitachi Capital Corporation, with a broad range of attractive occupations. For the future, on the basis of HFC expertise gained by working with

the Hitachi Group, we will propose this occupation-oriented service as a financial solution to many companies.

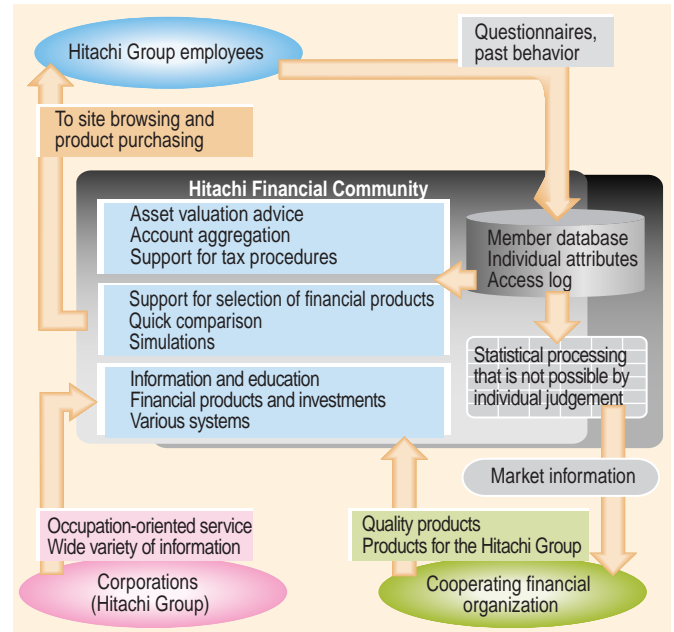

Overview of occupation-oriented financial solutions through the “Hitachi Financial Community”

## Version 6 of the HiRDB Scalable Database Featuring Multiple DB Functionality and Database Staticizing: the Solution for the Mission-critical Systems of 24-hour-a-day Web Businesses

In the web-oriented business field with its requirement for non-stop services, the database management system must provide quick fail-over and high levels of availability and allow the execution of database maintenance and batch jobs at the same time as online transactions.

Version 6 of the HiRDB provides two functions as the solution of the above problem. The first is a multiple DB function that allows access to multiple physical entities with the same table definition as different databases by having them on separate logical volumes created by either Hitachi’s Shadow Image disk-array subsystem or by some other software-mirroring feature. The second is database staticizing, which keeps databases consistent with data at all points in time. The two functions are integrated to achieve a non-stop service where it is possible to execute database maintenance or batch jobs at the same time as online transactions.

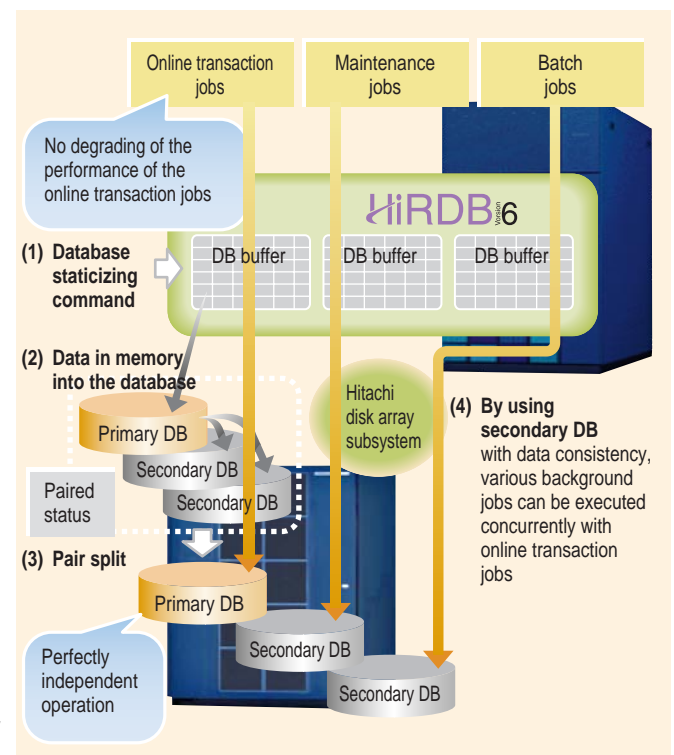

Using HiRDB Version 6 to provide non-stop service  
A non-stop service is achieved with HiRDB’s multiple DB function and database staticizing.

## Contents-check System for Preventing Dissemination of Falsified Information from Web Pages

Many services, such as electronic government and electronic commerce, are conducted via Internet websites; thus, maintaining the reliability of such services is a major challenge. In addition, since there has been a rash of attacks on websites by hackers, many users have a sense of insecurity when it comes to using websites.

The “contents-check system” developed by Hitachi, Ltd. continuously monitors information being sent out via a web browser and checks whether it has been tampered with. If the system detects tampered-with web-page information, it instantly substitutes that tampered web page with one that displays “Now in preparation.” In this way, the system prevents false information from being disseminated.

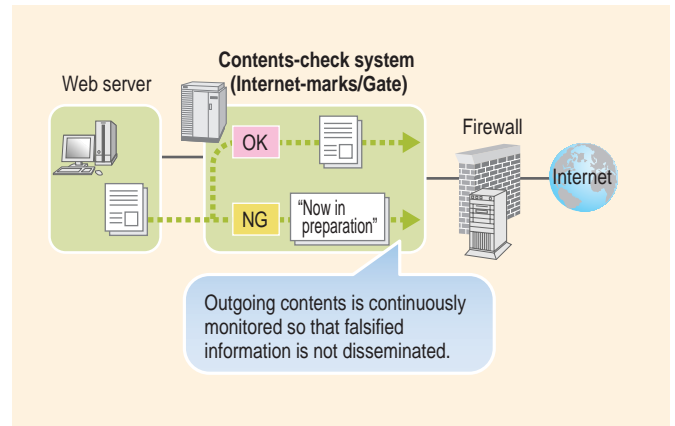

Configuration of the contents-check system

Outgoing information (based on data created on websites) from web browsers is continuously monitored.

## Sports-Information System Installed at the Japan Institute of Sports Sciences

A new sports-information system has been installed at the Japan Institute of Sports Sciences (JISS), a core organization for creating databases of sports information and for supporting medical research on sports.

This system has three main characteristic features. The first is a so-called “total sports clinic” based on medical data on individual athletes that creates training materials by integrating sports information from various sources (such as scientific journals) with actual images of, for example, an athlete’s movement. The second

feature — “game analysis” — can analyze formations being used in a particular ball game and then provide rapid feedback to individual players in the form of computer-graphic images. The third feature, called “biomechanics support,” can compare the movement of a trainee with a top-class athlete; that is, it combines actual images and computer-graphics images of an athlete’s movement with graphical analysis in the form of a time series. Comparing the two time series can then show the difference between the movements of the two athletes.



A view of the Japan Institute of Sports Sciences (JISS) and example images of game analysis. By means of computer-graphics images, an event can be reenacted from an individual athlete’s viewpoint, and the whole team’s zone of influence can be visually analyzed.

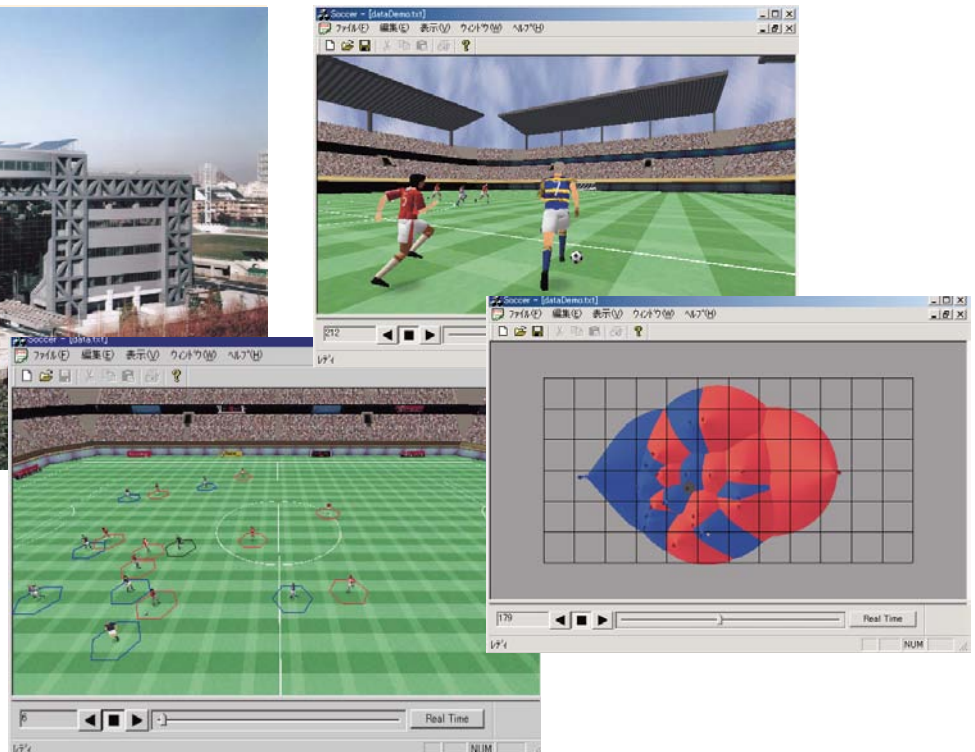

## Hitachi's NAS Products\*: Storage Systems that Enable Consolidation of SAN and NAS

With the continuing rapid increase in Internet business, the volume of data being distributed over networks has been increasing dramatically. There has been a corresponding increase in the need for the integration of information systems. As a way of satisfying this need, Hitachi, Ltd. has released the high-end/midrange disk array subsystem for use in storage area networks (SANs). In addition, the increasing diversity of computer systems is leading to an increasing need for NAS (network-attached storage), which allows file sharing among machines with heterogeneous execution environments.

Against this background, Hitachi, Ltd. has developed full-scale NAS products to supplement the existing line-up of SAN products, namely, Hitachi's high-end or midrange disk array subsystems. These NAS products are composed of a UNIX\*\* -based NAS engine and Hitachi's high-end or midrange disk array subsystem. This allows the configuration of a NAS shared file area to supplement a current SAN storage area, and areas of both types may co-exist in a single disk array subsystem. Hitachi's NAS products enable the integrated operational management of storage in a way that achieves high levels of performance and reliability.

The NAS products are suitable for those environments in which high levels of system availability are required, such as large-scale web hosting. They are also suitable for small- and mid-scale system environments where files are shared, Web content is managed, etc., at the departmental level.

### (1) High levels of availability

Hitachi's NAS products provide an architecture that eliminates single points of failure by combining clustered NAS engines with Hitachi's high-end/midrange disk array subsystem, which are highly appraised in terms of availability.

### (2) Ease of installation

Hitachi's NAS products are shipped after their resources have been set up for the final clustered configuration. Users are thus able to immediately connect them to their existing networks and proceed directly to making the directory and user settings.

At user sites where Hitachi's high-end disk array subsystem has already been installed, the user is able to use the surplus capacity of Hitachi's high-end disk array subsystem as a NAS shared file area by adding a NAS Box, which features a NAS engine.

### (3) Consolidating storage

Hitachi's NAS products provide for the co-existence of a SAN and a NAS area in a disk array subsystem, so storage capacity can be supplemented by both SAN and NAS access methods. Storage can thus be effectively consolidated and the

cost of storage management can be reduced, since centralized storage monitoring, integrated backup, etc., are possible.

\* Hitachi's NAS products are only available in Japan as the A-6517 Series.

Hitachi's high-end disk array subsystems are sold as the A-65A1 Series in Japan.

Hitachi's midrange disk array subsystems are sold as the A-6542 Series in Japan.

\*\* UNIX is a registered trademark in the U.S. and other countries, licensed exclusively through X/Open Company Limited.

\*\*\* Ethernet is a registered trademark of Xerox Corporation in the U.S.

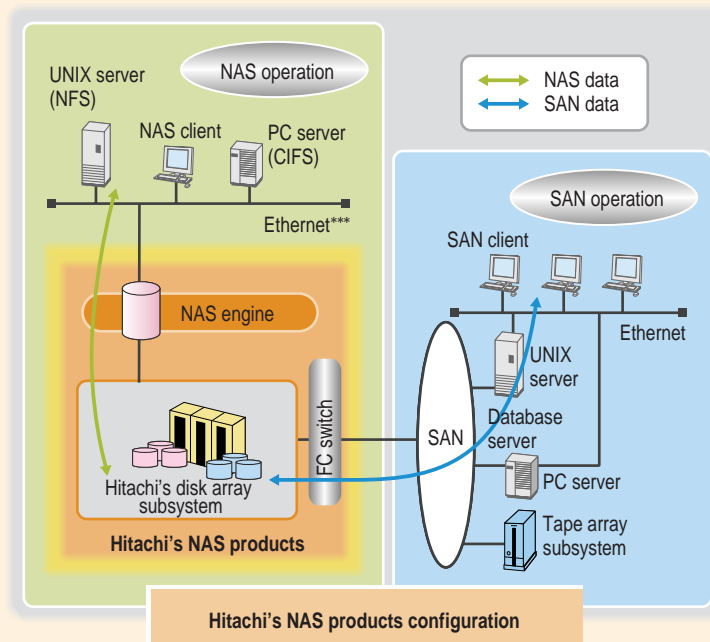
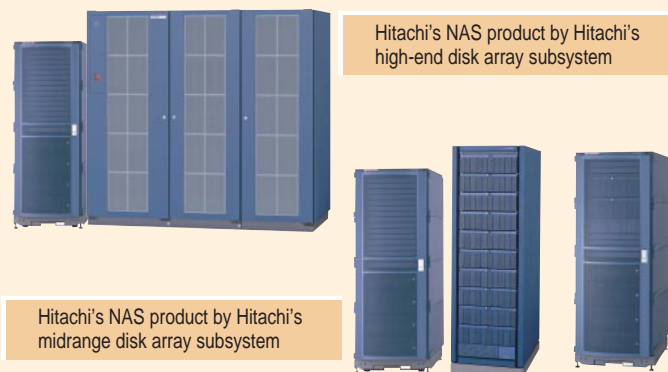

NFS: network file system  
CIFS: common Internet file system  
FC: fibre channel

Hitachi's NAS products allow the co-existence of SAN and NAS areas in a single disk array subsystem.



## Enhancing the Functionality of the Lightning 9900 Series Disk Array Subsystem

In June 2000, Hitachi, Ltd. released the Lightning 9900 Series disk array subsystem, which handles up to 27 Tbyte and allows effective consolidation of storage in large-scale SAN (storage area network) environments. We made improvements to the system's fundamental performance and functionality in June 2001. The major improvements are listed below:

### (1) Improved fundamental performance

We have improved the system's performance by tuning the hardware microprogram. The performance on random read operations is now up to 60% better than the previous performance. Moreover, support for a 2-Gbit/s fibre channel interface has been added to supplement the existing support for a 1-Gbit/s fibre channel interface.

### (2) Improved operability in terms of data protection and data sharing

Hitachi has improved the system's operability in terms of data protection and data sharing. For example, using a fibre channel link between the disk array subsystem at the main site and at the remote site brings a four-fold improvement in the performance of host-access processing for a remote-copy function.

### (3) Enhancement of management functionality

We have added control on a per-server (World Wide Name) basis to the Prioritized Port Control function, which previously only controlled server-access load on a per-channel-port basis. This function allows us to assign priority to the processing of applica-

tions according to the importance of online servers.

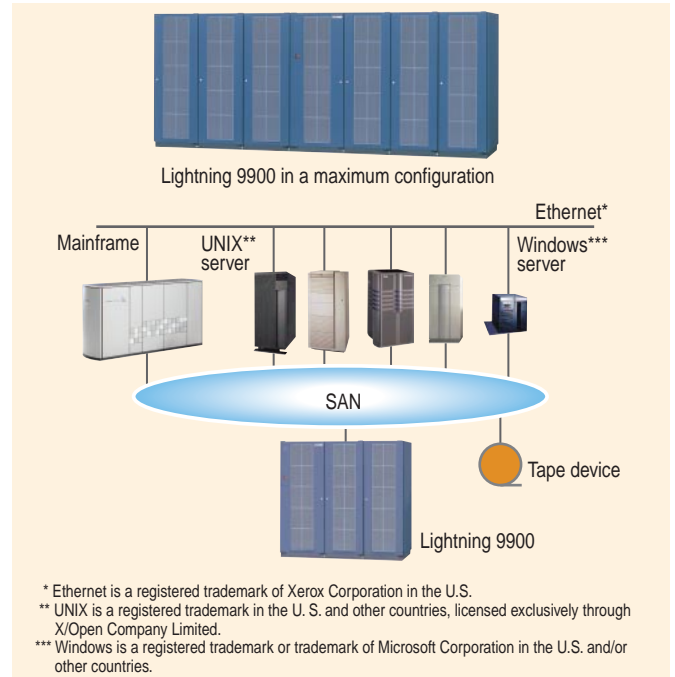

*The Lightning 9900 Series of disk array subsystems enables effective storage consolidation in large-scale SAN environments.*

## Improving the Functions of Thunder 9200™

The Thunder 9200™ storage system (maximum memory capacity: 6.6 Tbyte) was developed for use in storage-area network (SAN) environments. The following new features have now been included in the system.

Major new features:

(1) A 2-Gbyte-per-second fiber channel makes it possible for a Thunder 9200™ unit to transmit data at double the previous speed.

(2) A 15,000-rpm hard-disk drive (18 Gbyte) improves the system's performance in transaction processing.

(3) A multiple RAID-coupling feature-lite (MRCF-Lite) function supports the creation of replicas in the same subsystem as the original logical volume. This replica makes it possible to execute a backup operation and an on-line transaction at the same time without needing an extra application server and the increased load on the LAN.

Thunder 9200 is a trademark of Hitachi Data Systems Corporation.

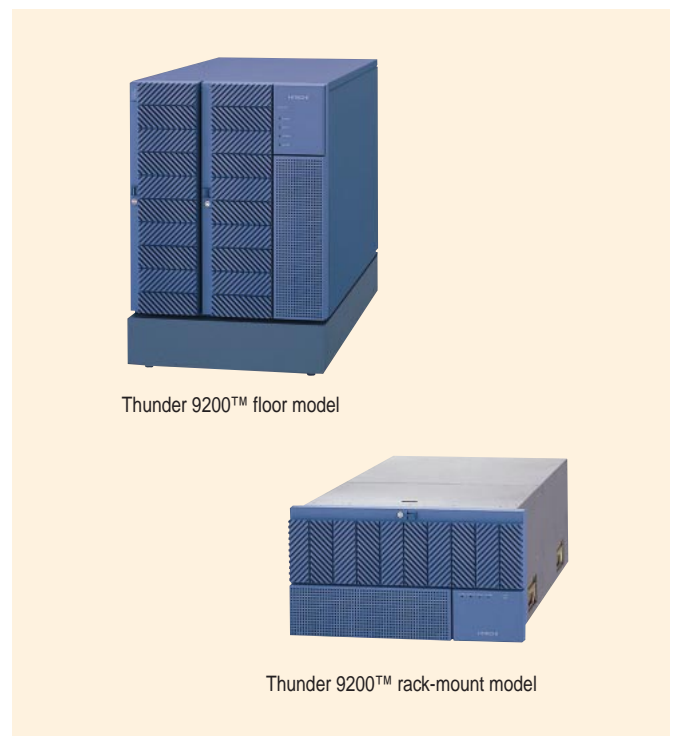

*A high-performance and highly reliable storage system that facilitates storage consolidation in the SAN environment*

## Enterprise Server UNIX\* Server Series

The lineup of high-performance and highly reliable open-platform UNIX\* servers for the mission-critical marketplace has been supplemented by five new models, including the high-end model 690.

Combining up to 32 POWER4\*\* processors with clock rates of 1.3 GHz or 1.1 GHz and a newly developed large level-3 cache achieves the world's highest level of performance for the model 690. Support for logical partitioning, with up to 16 partitions available, provides greater flexibility of system operation and satisfies needs such as server consolidation.

The new basic design methodology that was adopted and numerous new functions that were added provide dramatically improved RAS (reliability, availability, serviceability) features. The integration of two processors on a single chip and the use of MCM (multi-chip module) technology has minimized the total number of components and thus the number of potential points of failure. The POWER4 processor's synchronous machine-check interrupt and PCI (Peripheral Component Interconnection) Extended Error Handling will prevent machine crashes. The former mechanism is used to identify the affected processes, and this information is used to ensure that non-correctable hardware errors will have no impact on other partitions, the AIX\*\* kernel, or other user processes. PCI-bus errors are handled to limit the scope of the damage to a single PCI slot and the loss of use of the PCI adapter in that PCI slot; they thus do not lead to system

termination. Hot-swapping of power supplies, cooling fans, disks, and PCI adapters makes it possible to carry out maintenance without interrupting services.

\* UNIX is a registered trademark in the United States and other countries, licensed exclusively through X/Open Company Limited.

\*\* AIX and POWER4 are trademarks of the International Business Machines Corporation.



*The model 690 — The high-end model of the UNIX server series  
Up to 32 processors can be held in one rack; the advanced design of the rack is based on the Energy Mosaic concept and has been adopted for all of Hitachi's server and storage products.*

## Enterprise Server for Powerful Support of Mission-critical Work in the E-business Generation

The rapid spread of the broadband environment has enabled enterprises to start integrating their mission-critical work with e-business applications. This integration has consequently led to the dawn of a new era, namely, that of "enterprise net business" or E-business for short. Aiming at powerful support of this evolving E-business environment and development of new businesses, Hitachi, Ltd. has launched a new next-generation strategic server called the Enterprise Server. This server features a 64-bit architecture that enables advanced collaboration between web applications and mission-critical work.

Main features of the Enterprise Server:

By adopting a 64-bit architecture based on newly developed CMOS (complementary metal-oxide semiconductor) processors, the Enterprise Server can expand the scale of on-line operations, as well as speed up database and batch processing, while operating within the existing system environment.

To provide the high reliability necessary for mission-critical work, the Enterprise Server utilizes a redundant configuration in the processors and memory making up the server's core as well as in the power supply and cooling components. This enables switching to an alternate component whenever a fault occurs so that mission-critical work can continue without disruption.

Regarding the server's operating systems, Hitachi's virtual-storage operating system (which provides the main support for mission-critical work) as well as Linux\* are implemented. This combination of operating systems represents an "all-in-one" server configuration for supporting Web applications.

The system also supports high-speed, flexible connections to peripherals on various channels. In particular, through fiber channels utilizing a fiber-connection architecture, close cooperation with Hitachi's large-scale, high-reliability disk-array subsystem is possible.

This cooperation enables the SAN storage to be managed and the backbone databases to be constructed effectively.

\* Linux is a trademark or registered trademark of Linus Torvalds of the U.S. and other countries.

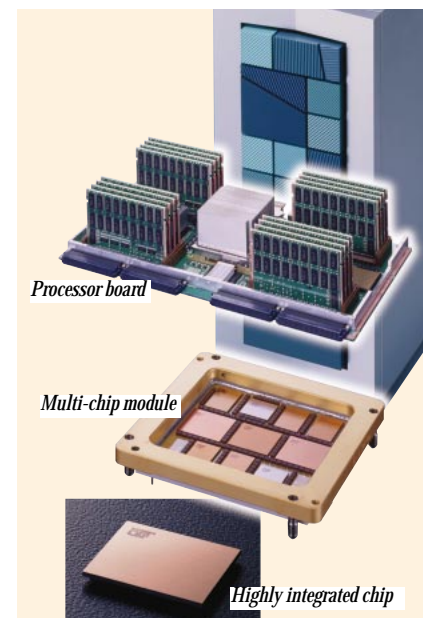

*Hitachi's latest enterprise server technology featuring high cost performance*

## Compact Multi-Function ATM Combines Payment-statement Handling and ATM Functions

A new ATM has been developed that combines payment-statement handling and the cash and account settlements in relation to the payment with the standard ATM functions of bank-note and coin handling, card handling, and passbook handling. This ATM includes a handset and keys with dynamic Braille labeling to satisfy barrier-free standards for the handicapped.

The most compact components on the market, which have been made possible by new design technologies, were used within this ATM. The machine thus makes up very little space. The ATM also surpasses superior image-processing technologies by which users can handle the ATM in minimal errors and easy operations.



*Compact multi-function ATM*

*The ATM was designed with reduced dimensions to allow its placement in small spaces. The image processing technology enables the handling of payment statements.*

## New Bill-recycling Module Requires Minimal Space, Has a Large Capacity, and Accommodates China's Bank Notes

A bill-recycling ATM for international use has been developed. The machine is able to handle a variety of currencies, including the Chinese bank notes. The dimensions of the new module have been reduced to only 60% of those of the domestic model (57-cm wide × 63-cm deep), yet it has a large storage capacity (7,000 bank notes) which enables long periods of operation without restocking. A single module handles both withdrawals and deposits of cash. The mechanism allows for a maximum of 100 notes per transaction. The large 15-inch monitor and World-Wide-Web-compatible software allows for effortless operation.



*The bill-recycling ATM for international use*

*The new bill-recycling module was developed to accommodate world-wide currencies including the Chinese currency, takes up minimal space, and is capable of storing large quantities of bank notes.*

## Hitachi's IPv6 Network Construction Support Solution

Japan's IPv6 Promotion Council has adopted Hitachi's gigabit router- and Job Management Partner 1 (JP1)-based IPv6 solution as its IPv6 experimental system.

Hitachi has taken advantage of its long-term experience and know-how with regard to IPv6 in setting up and delivering an access network for a demonstration experiment on the combination of an IPv6 access network and digital home appliances that was carried out by the IPv6 Promotion Council.

The IPv6 Promotion Council was established in October 2000 with the Ministry of Public Management, Home Affairs, Posts and Telecommunications as the observer. Its goal is to popularize the concept of the IPv6-based next-generation Internet by gathering knowledge in a variety of fields from public corporations, governmental and nongovernmental organizations and individual users and disseminating the knowledge among these parties.

The e-Japan Priority Policy Program was formulated in March 2001 with the goal of realizing an IPv6-based Internet environment by 2005 so that all people in Japan are able to securely, quickly and easily receive, process, and transmit desired information at any location. The IPv6 Council was founded to realize this national policy, and along with the broadcasting media and Ministry of Public Management, Home Affairs, Post and Telecommunications promotes demonstration experiments on the use of IPv6 in digital home appliances. The council is also responsible for studies of the management of addresses during the period of changeover to IPv6, investigating the looming shortage of IPv4 addresses and the need for IPv6 addresses, and promoting IPv6 at a variety of events and showrooms.

The experiment that concerns us here was intended to promote the use of IPv6 by having monitors recruited through advertisements actually use the IPv6-based broadband access network with IPv6-based digital appliances to identify technical problems and investigate market needs.

Among the members of the IPv6 Promotion Council, Hitachi has helped usen Corp. to carry out an experiment on broadband access for ordinary users and Tokyo Metallic Communications

Corp. to carry out an experiment on IPv6 broadband access using xDSL. Hitachi also helped IP REVOLUTION, INC. to use fiber optics to provide an IPv6 test environment for The center for Information Science, Kogakuin University and the Tokyo University of Science. In each of these cases, Hitachi provided a network development solution that was tailored to the goals of the experiment for the corresponding carrier and ISP (Internet service provider) and to the corresponding IPv6 operation plan.

Hitachi took advantage of its long experience with IPv6 solution technology in establishing the IPv6 network systems. Hitachi's gigabit routers and the JP1 integrated system operation manager from Hitachi provided the core equipment and manager, respectively; these items were supplemented by equipment from other vendors.

Hitachi's gigabit router was adopted because it has the following highly evaluated features:

- (1) Its hardware processes IPv6 addresses at a high speed (this is an indispensable prerequisite of a backbone router).
- (2) A variety of IPv6 functions such as BGP4+ (border gateway protocol 4+), OSPFv3 (version 3 of open shortest path first) and RIPng (routing information protocol next generation) are supported.
- (3) It has a long track record having been applied by a variety of carriers, iDCs (Internet data centers), and ISPs that operate according to IPv6.

The JP1 integrated system operation manager was adopted because it has the following strong points:

- (1) JP1 had been verified as working well with the GR2000 and the software is very stable.
- (2) JP1 provides GUI (graphical user interface)-based IPv6 network management.

This experiment allowed carriers and ISPs to study problems in the provision of IPv6 services and to gain operational knowhow. It is planned that the results of the experiment are used as feedback in starting to study the introduction of practical commercial service.

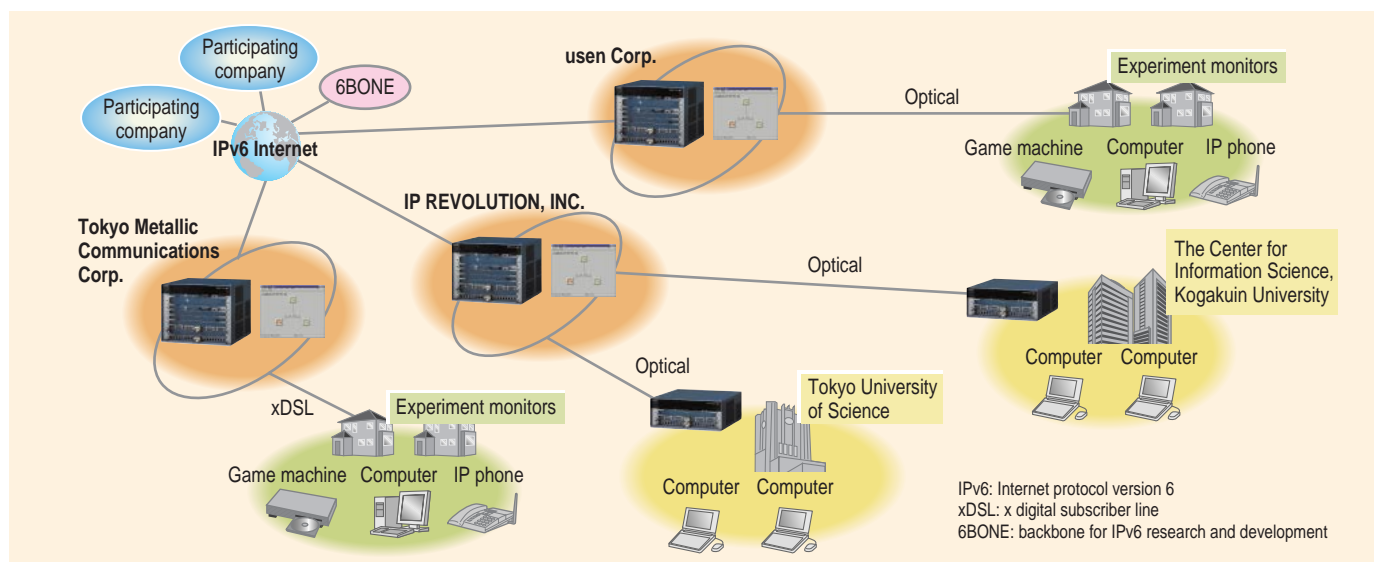

Hitachi's IPv6 Internet Connection System for an experiment supported by the IPv6 Promotion Council  
 Hitachi contributed and established a reliable IPv6 access network for an experiment of the IPv6 Promotion Council.

## Web-gateway System Solution to Support Network-based Delivery of Digital Contents

The market for digital contents is growing rapidly as is the number of businesses that supply contents. This is because of the advancement of broadband and mobile Internet technologies. A variety of contents, such as game software, pictures, and streaming videos, are being downloaded to tens of millions of users through both wired and wireless IP connections.

The web-gateway system is designed as a common application platform on which network carriers and service providers can realize various types of content-based business. It features traffic control for the scalable and reliable delivery of contents and to allow the implementation of revenue-increasing applications in relation to contents-based business. The central part of this system is an original proxy server from Hitachi, the flexible web gateway server (FWGS). The software runs on a PC under Linux\*. The FWGS provides traffic-control features such as distributed cache control, priority control, and congestion control, that facilitate scalable and stable contents-delivery services. The FWGS is interoperable with such back-office servers as the authentication-database, fee-collection and administration servers, thus helping the user to realize value-added applications like contents charging, user authentication and user/contents priority control.

Here are three areas of application for Hitachi's web-gateway solution:

### (1) Mobile web-gateway system

The congestion control, contents charging, authentication control, and other features of Hitachi's web-gateway system make it ideal for use as the gateway to services for the delivery of contents over mobile networks.

### (2) Distributed cache system for large-scale contents-delivery services

The web-gateway system's features that facilitate centralized management, including cache and priority control, give it strong advantages as the front-end of cache system of this type.

### (3) Front-end systems for large-scale web sites

The gateway's traffic control features, such as priority control, queuing control, and traffic monitoring, make it particularly suitable in this role.

The requirements for contents-delivery services are changing with the arrival of new technologies and business models. Further enhancements to the web-gateway system are being planned and will realize additional services such as the delivery of streaming contents, security checking, and advertising services. The web-gateway system will keep evolving as an application platform in the IP networks of the next generation.

\* Linux is a trademark or registered trademark of Linus Torvalds of the U.S. and other countries.

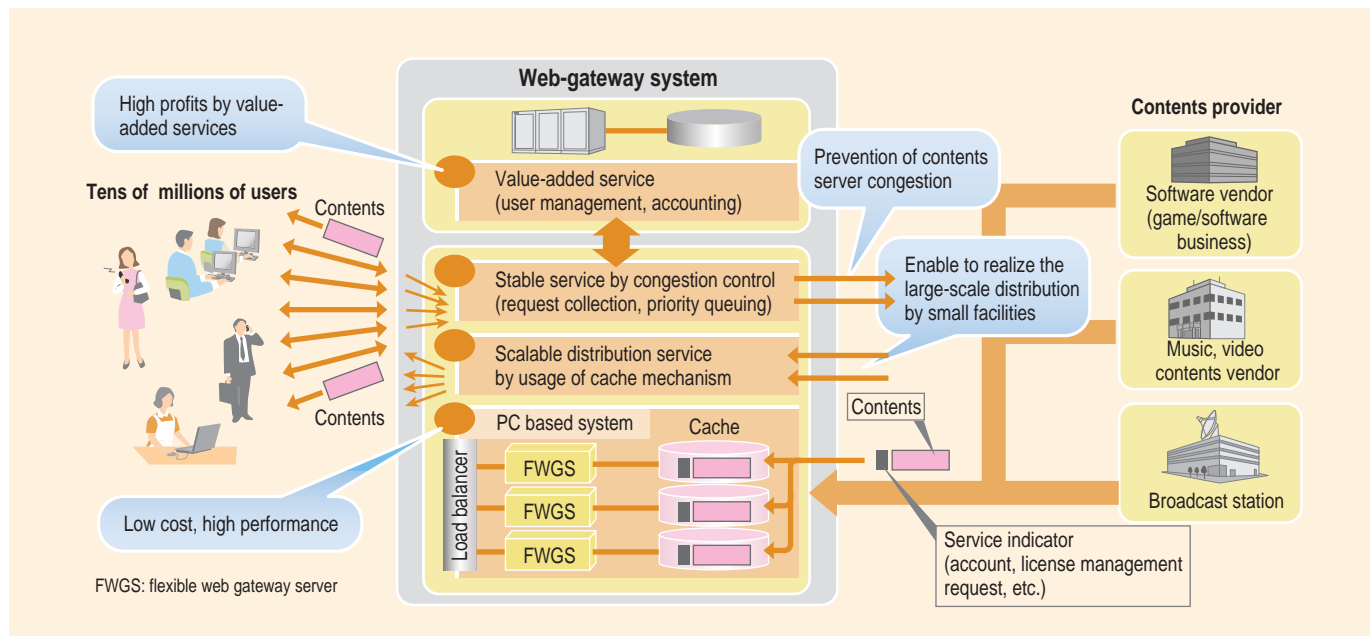

### Hitachi's web-gateway system

The web-gateway system makes it possible for contents providers to provide stable services to tens of millions of users with a small-scale server system. It also allows network carriers and service providers to create revenue-increasing value-added services.

## AMN1100 Series of Optical Ethernet\* Converter

The AMN1100 series is a line of media converters (MCs) which realizes long-distance transmission for access networks by converting Ethernet frames into optical signals. WDM (wavelength division multiplexing) technology is applied in AMN1100-series products to realize bidirectional communication via a single optical fiber. The series currently consists of two models, which differ according to the method of optical access : a PON (passive optical network) type and an SS (single star) type.

In the PON type media converter, an optical splitter is installed between the central equipment and the user equipment to allow a maximum of 32 users to share a single optical fiber. It also lowers per-user-circuit cost, and the cost of space for the central equipment. A media converter of the SS type, on the other hand, is for a 1-to-1 connection between the central equipment and user equipment and is intended to ease the building of simple networks.

The main features of the two models are as follows:

[Common]

- (1) Application of WDM technology to implement bidirectional transmission over a single optical fiber.
- (2) Provision of an auto-negotiation function to allow the selection of a communications method which is suitable for equipment on a customer's premises.
- (3) An SNMP (simple network management protocol) manager provides support for remote monitoring/control and loopback-

test functions between user equipment at remote sites and central equipment.

[PON type: AMN1100-P]

- (1) Provision of an optical interface that complies with ITU-T recommendation G. 983.1.
- (2) The user is able to take advantage of the latest PON-based optical technology to extend LAN segments by up to 20 km.
- (3) Provides for per-line broadband-access speeds of up to 100-Mbit/s (typically 6 Mbit/s, both upstream and downstream, when branching is into 16 lines).
- (4) Provides security through support for the Virtual LAN (IEEE802.1Q).
- (5) Two types of center equipment are available: i.e., a box type (up to 32 lines) and a unit type (up to 704 lines)

[SS type: AMN1100-S]

- (1) The optical interface complies with 100BASE-FX (IEEE802.3).
- (2) The user is able to take advantage of the latest SS-based optical technology to extend LAN segments by up to 40 km.
- (3) Up to 21 lines may be accommodated by adding a communications card for each line.

\* Ethernet is a registered trademark of Xerox Corporation in the U.S.

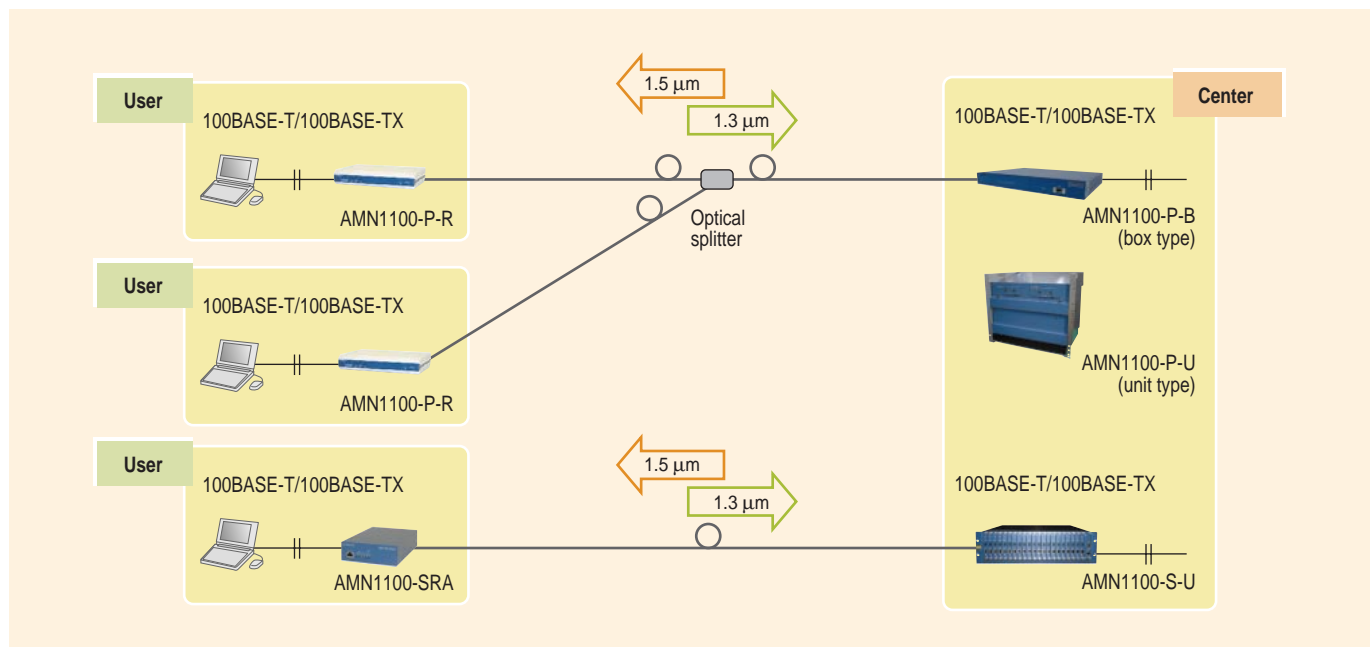

Example configurations for AMN1100 series optical Ethernet converters

Wavelength division multiplexing technology is applied in the system to realize bidirectional communication via a single optical fiber.

Two types provided for selection according to the user's needs: i.e. the AMN1100-P PON-type where an optical splitter is used (upper configuration), and the AMN1100-S-SS-type converter (lower).

## Hitachi's IPv4/v6 Broadband-access Gateway

With the spread of broadband Internet access through such means as ADSL, CATV, and FTTH, Internet users are increasingly demanding connection at speeds greater than 1 Mbit/s. There is now a strong demand for network-access equipment that operates according to a high-speed Internet-processing protocol to provide flexible support for these access methods along with high data-transfer rates.

Furthermore, the increase in the number of the Internet users is expected to lead to a shortage of IPv4 addresses. Both the more effective use of IPv4 resources and the introduction of the equipment which operates according to IPv6 are very important goals. Telecommunications carriers are now promoting the construction of an IPv6 network to provide new services for digital home appliances and mobile terminals.

Our broadband access gateway is a very compact and high-performance access gateway that supports both IPv4 and IPv6. In addition, the broadband access gateway achieves high throughput by using an NP (network processor) for packet processing. There are two models; the broadband access server and the address translator.

The broadband access server is an IPv4/IPv6 dual-stack broadband access server that can accommodate access according to a variety of broadband methods, such as ADSL, CATV and FTTH. When an access request is received, the broadband access server authenticates the user, allocates an IP address and configures an L2TP (Layer 2 Tunneling Protocol) tunnel in the access network if this is required. Telecommunications carriers that use the broadband access server are able to provide a robust broadband-access environment for their users.

The address translator is an IPv4/IPv6 address translator which creates a bidirectional interconnection between an IPv4 network and IPv6 network. The address translator provides for the smooth migration of telecommunications carriers from existing IPv4 equipment to IPv6 equipment. It also provides interoperability with IPv6 to IPv4 networks that have been constructed as private corporate networks.

By effectively applying the broadband access server and the address translator, telecommunication carriers, enterprises and the like can improve their future network architectures. These devices are compact and powerful so they help the user to more effectively use physical space. They also facilitate the control of broadband service quality and the maintenance of a network environment in which IPv4 and IPv6 coexist. The latter feature is particularly helpful to users who have the intention of creating new services.

The main features of the two models are as follows:

[Common]

- (1) High service density and performance are provided in a compact 2U (89 mm) size housing.
- (2) A high speed and flexible architecture are realized by using NP (network processor).

The NP realizes flexibility in software processing along with high-performance hardware-level processing. Hitachi's broadband access gateway achieves high-throughput packet processing for access networks to which users are connected through a wide variety of high-speed access methods. It is easy to add new functions to a broadband access gateway after it has been installed. This reduces costs for telecommunications carriers, since it eliminates the need for them to replace devices on the network when they introduce new services.

- (3) Flexibility and scalability for networks at all scales.

[Broadband Access Server]

- (1) A maximum rate of 4-Gbit/s in packet forwarding performance
- (2) As many as 16,384 PPP (point-to-point protocol) sessions
- (3) IPv4/IPv6 dual protocol-stack feature
- (4) Server redirection at LAC (L2TP access concentrator) will be implemented in the near future

Content-delivery servers/cache servers may be placed on the LAC sides of L2TP tunnels. This makes it possible to reduce the bandwidth of the access network and makes it easy to secure QoS for VoIP, streaming, etc. by setting content servers/cache servers at the LAC side of the L2TP tunnels.

[IPv4/v6 Address Translator]

- (1) 2-Gbit/s address translation for the highest performance in the industry
- (2) Very large scale: 16,384 address-translation entries
- (3) Bidirectional address translation allows access from IPv4 clients to IPv6 servers and vice versa.

Suitable for carriers that are providing IPv6 services, and for enterprises and content holders who need to migrate from existing IPv4 networks to IPv6 networks.

- (4) Address translation for IP packets travelling between multiple IPv4 private address networks.

Application example: integration of enterprise networks

- (5) Automatic generation of translator's address-translation entries
- (6) DNS (Domain Name System) load-balancing function:

The load of translation is balanced among the translators to improve the network's reliability. This is achieved by varying the translators' addresses in translator-dedicated DNS replies.

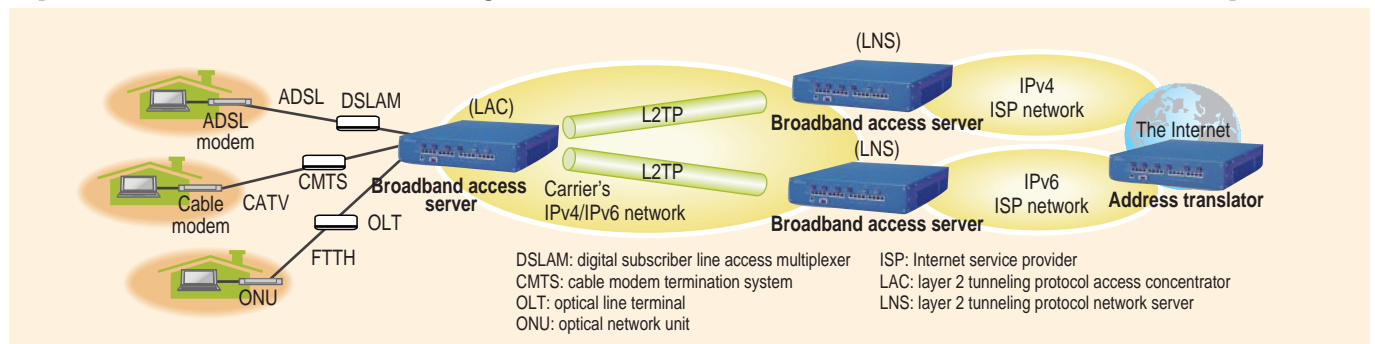

Example of configuring a broadband access network application of the broadband access server and the address translator  
 The broadband access server accommodates a variety of types of broadband-access lines, such as ADSL, CATV and FTTH.  
 The address translator bidirectionally interconnects an IPv4 network and IPv6 network.

## IPv6 Enhancement of Hitachi's Gigabit Router

Hitachi's gigabit router has been enhanced with dedicated hardware that provides support for the IPv6 (Internet Protocol version 6) next-generation Internet protocol.

The gigabit router provides the following key IPv6-related features and is thus realizing the high-speed backbone of a ubiquitous network connecting an enormous number of computers, mobile terminals and information appliances.

(1) High-speed processing of IPv6 packets

The router supports IPv6 protocol suite enabling huge space of addresses ( $2^{128}$ ). All of the processes involved in IPv6 packet routing, such as forwarding, filtering, QoS (Quality of Service) control and tunneling, are executed by dedicated hardware\* on high-speed links so that software-based processing by a general-purpose CPU is not required. This implementation realizes high-speed communications in the actual IPv6 environment.

(2) Broad range of applicability and scalability

The seven models of this series meet routing requirements across the range from enterprises to carriers; the line interfaces handle the range from low (64 kbit/s) to high (2.4 Gbit/s) rates. Each line card forwards IPv6 packets by line rate. The full suite of IPv6 protocol support means that the gigabit routers can adapt to various kinds of IPv6 networks.

(3) Flexible IPv6 administration and management

The gigabit router has advanced functions of IPv4 to IPv6 transition such as dual stack, one IPv4 and one IPv6, IPv6 over an IPv4 tunnel and IPv4 over an IPv6 tunnel. Furthermore, it provides practical IPv6 network management functions that are at the same level as current IPv4 network management functions; these include the IPv6-MIB (management information base), path-reachability checking tool, and logging and configuration tools.

\* A gigabit router shown lower right-hand corner does not support hardware-based IPv6 forwarding.

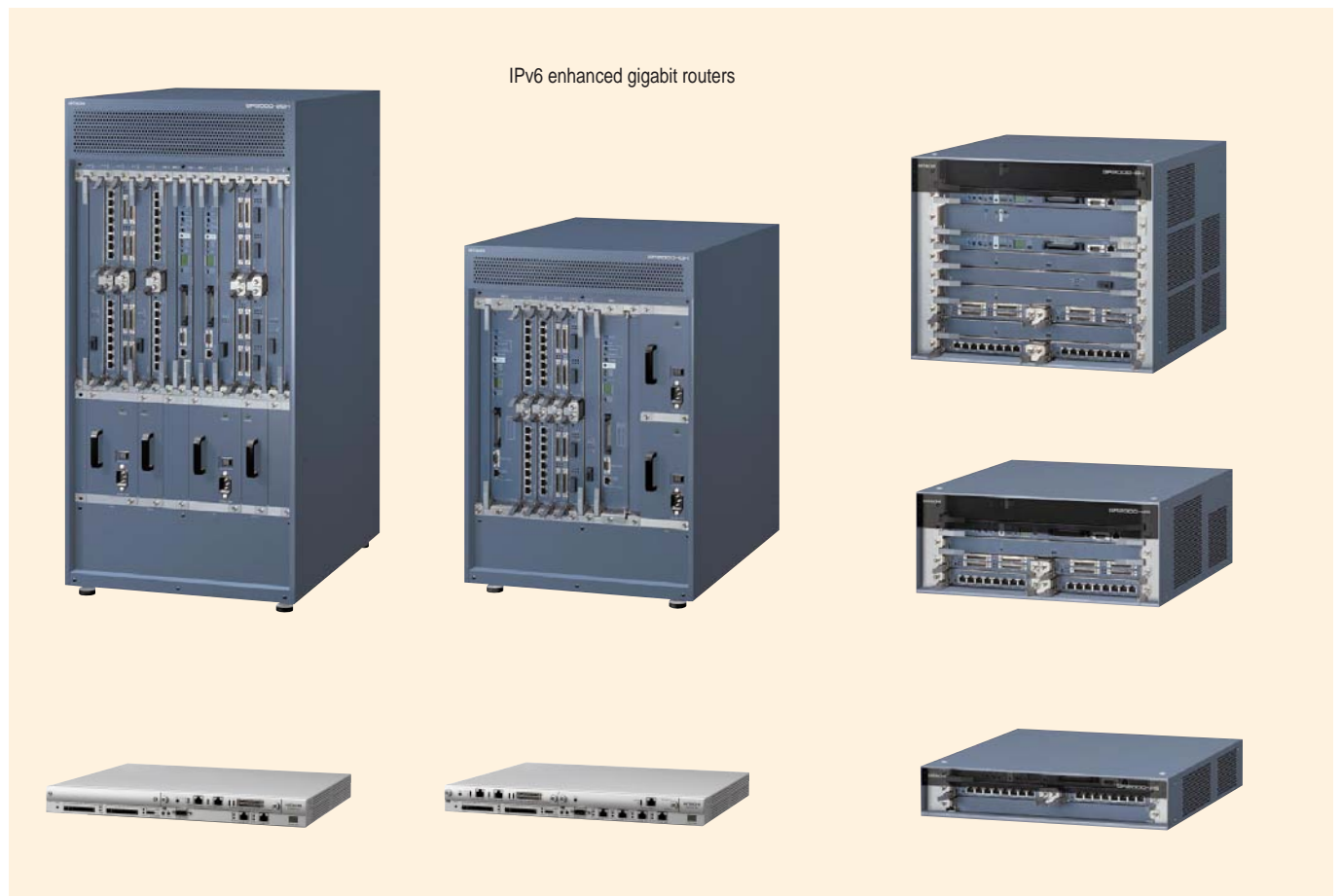

*Hitachi's gigabit routers*

*Dedicated hardware in Hitachi's gigabit routers supports packet routing according to IPv6.*



# OSEM Solution that Supports DWDM Optical Transport Networks

Dense wavelength division multiplexing (DWDM) systems are being introduced into the backbones of optical transport networks. High speeds of 10 Gbit/s per channel are getting popular today.

In response to these circumstances, Hitachi, Ltd. has introduced the AMN6100 DWDM system with 10 Gbit/s × 128 channels, or 1.28 Tbit/s in total. To meet the pace of the development of DWDM optical transport networks, the company has recently developed an optical signal expander module (OSEM), which is designed to make the AMN6100 more functional. The OSEM meets the requirement for transmission over distances of greater than 1,040 km, and in fact achieves a transmission distance of up to 8,000 km. The function of wavelength conversion in the module has been enhanced to make more effective use of installed fiber runs. The function of wavelength selection has been enhanced, too, so that the user is able to build a flexible network. Optical transport-network solutions are thereby offered.

The "AMN6100" is used in the optical transport networks which are provided by Global Crossing Ltd. and Norlight

Telecommunications, Inc. in the USA.

Main features of the OSEM are as follows:

- (1) In addition to a transmission distance of 1,040 km, the OSEM minimizes the effect of chromatic dispersion and mitigates PMD (polarization mode dispersion) within a line amplifier (LA) to further eliminate the factors that cause deterioration of the transmitted signal (such as gain tilt, dispersion, and polarization-mode dispersion), thus achieving a transmission distance of up to 8,000 km.
- (2) Wavelength conversion makes it possible to design networks on a band basis. This makes it possible to select the optimal wavelength according to the conditions of fiber transmission.
- (3) Wavelength selection makes it possible to design networks on a wavelength basis and to meet mesh-type networks, because it does not depend on the conditions for a given transmission line (such as the loss characteristics for a particular type of fiber).
- (4) A compact design that allows the OSEM to be incorporated in any LA desired on a wavelength basis makes the effective use of the space available at the LA site possible.

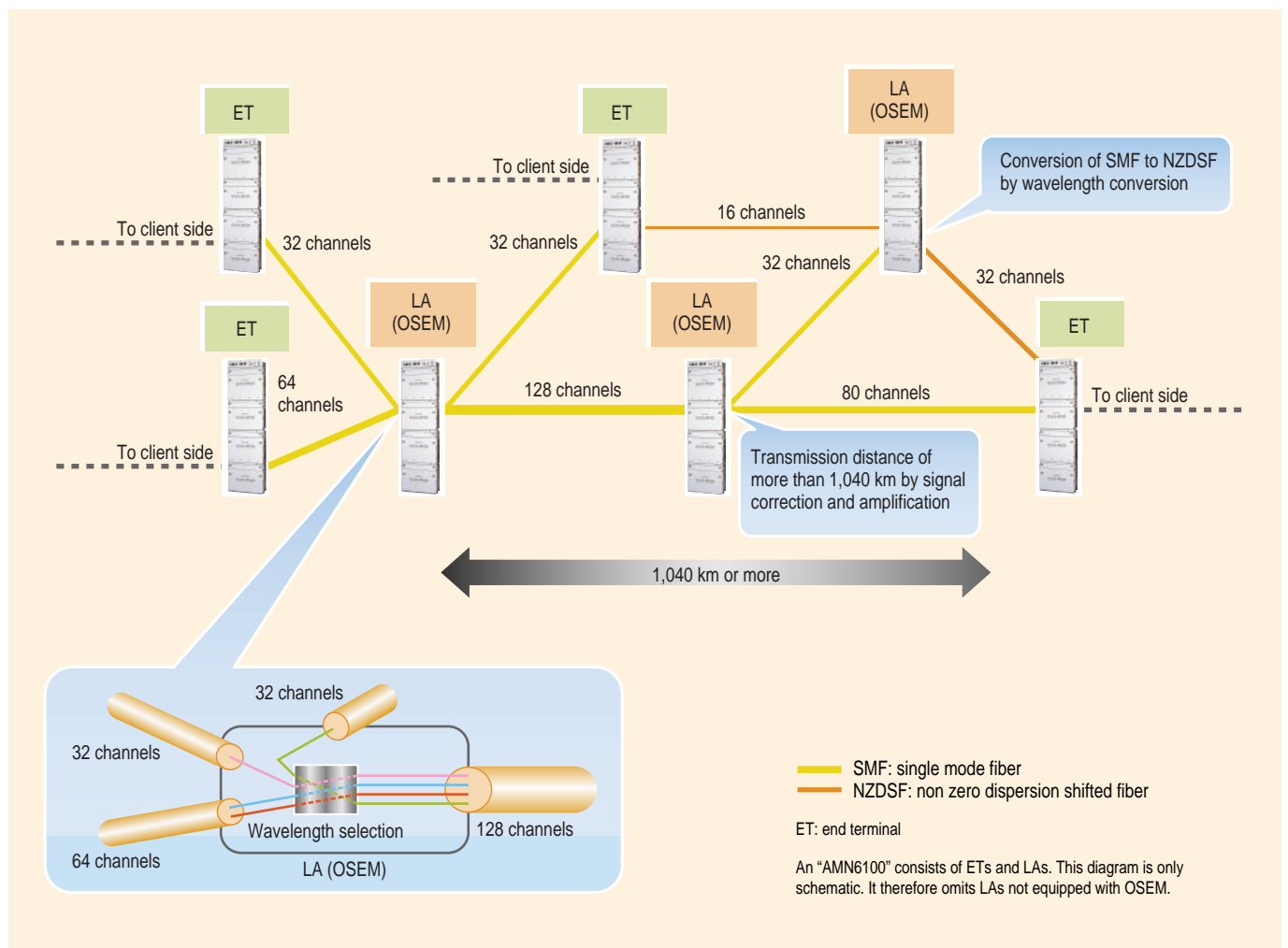

Typical application (schematic diagram) of AMN6100/OSEM units in a DWDM optical transport network  
 The AMN6100 makes it possible to build a flexible networks suited for the particular transmission lines and traffic levels by wavelength selection of the OSEM in the LA.

## OTN Transponder Equipment for DWDM Optical Transport Systems (AMN 7100)

Hitachi's AMN 7100 Flex Lambda Terminal is a wavelength transponder that provides 2.5- to 10-Gbit/s services on an AMN 6100 dense wavelength multiplexing (DWDM) ultra-long-haul transport platform.

The terminal offers open optical interfaces from a variety of equipment suppliers so that it is able to carry various types of traffic, including SONET (synchronous optical network), SDH (synchronous digital hierarchy), ATM (asynchronous transfer mode) and IP (Internet protocol).

The AMN 7100 consists of transponder cards for 10-Gbit/s tributary signals and multiplex cards with multiplexing functionality for 2.5-Gbit/s tributary signals. Both cards have ITU-T G.709 compliant OTN (optical transport network) overhead-processing function that provides rich management capabilities to DWDM network operators. Furthermore, these cards have an FEC (forward error correction) function in which Reed-Solomon codes are applied to improve the effective bit error rates in long-haul transmission.

The multiplex card also has a function for the efficient use of lambda resources, where four 2.5-Gbit/s tributary inputs are multiplexed into a single 10-Gbit/s signal. The card provides a transparent transport function, transferring tributary-signal overheads, such as automatic protection switch, order wire and data communication channel without modification through the 10-Gbit/s backbone network. This transparent transport function is accomplished by transmitting the overhead of the tributary signals in unused overhead of the OC-192 overhead bytes. Tributary-network providers are able to use this feature to transfer their own OAM (operation, administration and maintenance)

signals via Hitachi's DWDM network. The combination of the multiplexing function and the transparent transport function allows service providers to maximally utilize the valuable fiber infrastructure.

The AMN 6100 DWDM system with the AMN 7100 enlarges the capacity available on a fiber, and achieves a bandwidth of 1.28 Tbit/s. Hitachi's AMN 6100 and AMN 7100 DWDM systems have been awarded orders from Global Crossing Ltd. and Norlight Telecommunications, Inc. in the USA.

The major features of the AMN 7100 are as follows:

- (1) High density and small footprint; Up to 33 transponder cards or multiplex cards in a 7-foot NEBS (network equipment building system) bay.
- (2) Up to 128-channel capacity at 10-Gbit/s transfer rate in the AMN 6100 system using the AMN 7100's C-band and L-band wavelength sources interleaved with the 50-GHz spacing on any fiber.
- (3) The multiplex cards can operate as tributary multiplexers for DWDM equipment, thus realizing more efficient use of the lambda resources in a fiber.
- (4) An ITU-T G.709 compliant OTN overhead-processing function for DWDM network operation, administration and maintenance.
- (5) A Telcordia GR-253-CORE and ITU-T G.707 compliant SONET/SDH overhead-monitoring function for tributary signal.
- (6) Improved transmission capability (additional 6-dB margin) due to the application of a powerful FEC function, 8-byte correction based on a Reed-Solomon code.
- (7) Ability to interface with many types of client traffic, such as SONET, SDH, ATM and IP.

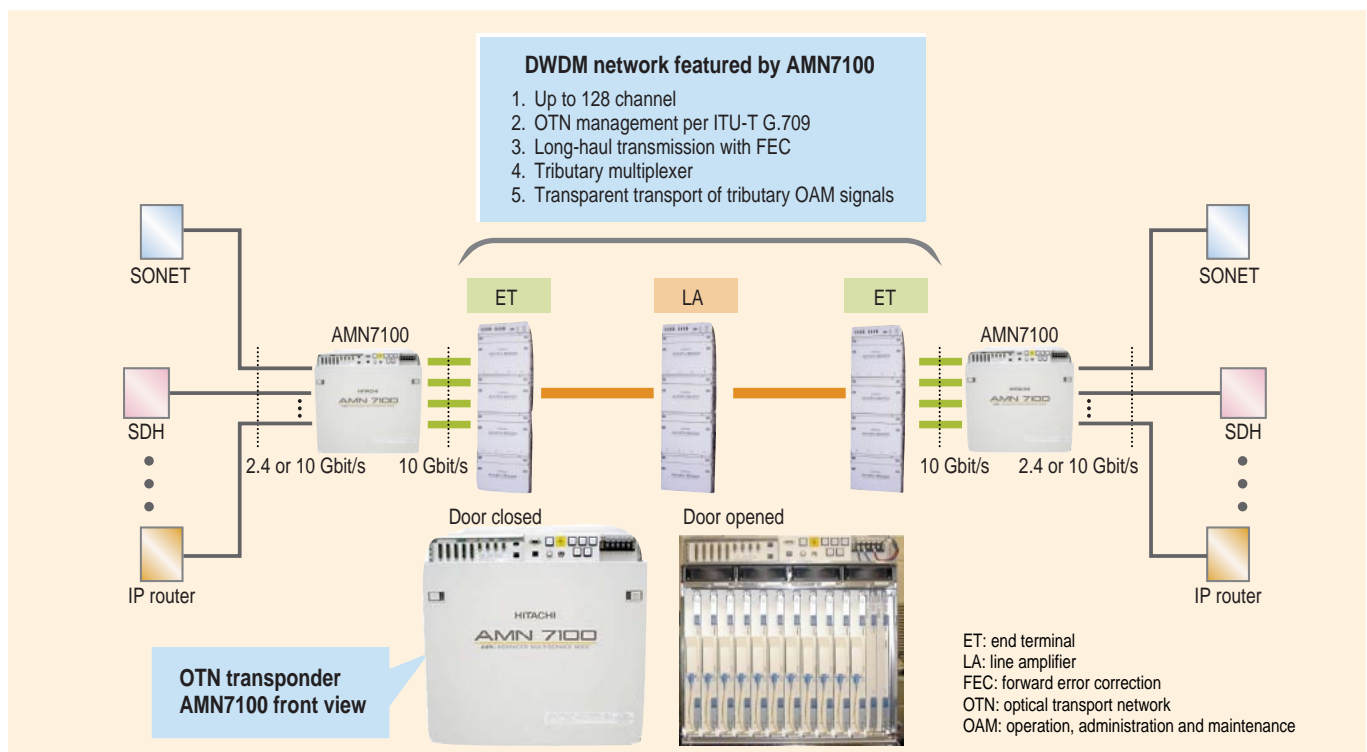

A DWDM network with an OTN transponder

AMN7100 OTN transponder allows the efficient connection of various types of traffic from a variety of equipment with a large-capacity backbone network.

## 40-Gbit/s Optical Transmitter and Receiver Modules

With the explosive growth of the Internet, high-speed fiber-optic networks, currently constructed with 10 Gbit/s and WDM (Wavelength Division Multiplexing) technology, are demanding the next generation of 40-Gbit/s technology to realize higher transmission capacities. In line with these market needs, OpNext, Inc. has developed a 40-Gbit/s optical transmitter and receiver module which can be used at the front-end of a fiber-optic network system.

The major features of the module are as follows:

- (1) The transmitter consists of a 4-to-1 multiplexer and an optical transmitter. The receiver includes an optical receiver and a 1-to-4 demultiplexer. The multiplexer and demultiplexer achieve an interface of 4 channels at 10 Gbit/s.
- (2) The optical transmitter and receiver incorporate high-speed ICs fabricated with InP (indium phosphide) technology, which provides an exceedingly good high-frequency response. A SiGe (silicon germanium) process, which proves higher densities of integration, was used in manufacturing the multiplexer and demultiplexer ICs.
- (3) The newly designed 40-Gbit/s semiconductor-based optical modulator enables low-voltage operation. The integration of the optical modulator and its driver IC in a compact package leads to wide eye-openings for optical signals modulated at 40 Gbit/s.
- (4) The optical receiver incorporates a photo-detector module

with integrated pre-amplifier which exhibits a broadband and flat frequency response up to 40 GHz. The receiver has clock extraction and decision circuits to realize the 3R (reshaping, retiming, regenerating) functions.

- (5) Stable and error-free data transmission was confirmed with a 40-Gbit/s NRZ (non-return-to-zero) PRBS (pseudo random binary sequence) of  $2^{31}-1$  data over 2 km of dispersion-shifted optical fiber.

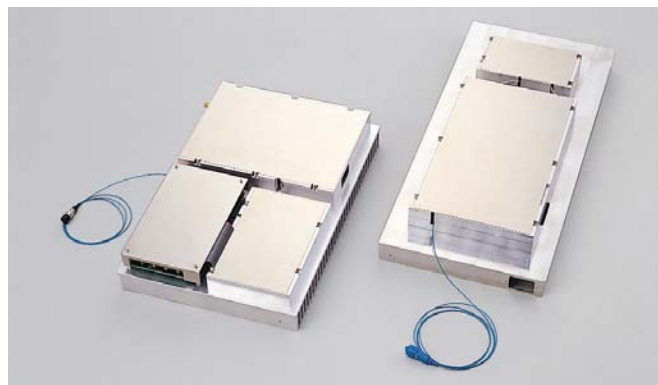

40-Gbit/s optical transmitter and receiver module

An optical transmitter module with a 4-to-1 multiplexer (left) and an optical receiver module with a 1-to-4 demultiplexer (right).

## Highly-integrated and Compact 10-Gbit/s Optical Transceiver Modules Featuring with MSA-specifications Compliance

OpNext, Inc. has developed 10-Gbit/s fiber-optic transceiver modules with a 16 : 1 multiplexing (MUX) and 1:16 demultiplexing (DEMUX) circuit. These modules can be used in high-speed optical network systems, Internet Protocol (IP) switches, and IP routers. With the use of silicon-germanium ICs, CMOS ICs, and a direct-modulation laser diode with a wide operating temperature range, a device that is both compact (64 mm × 89 mm × 13.7 mm) and low power consumption (6.2 W) has been achieved.

The transmission distances are 600 m for the Fabri-Perot laser diode type, and 2 km and 12 km for the distributed-feedback laser diode type. The optical and electrical interface is compatible with modules from other MSA (multi-source agreement) vendors, including those which are overseas. OpNext, Inc. started to sell these devices in April 2001.

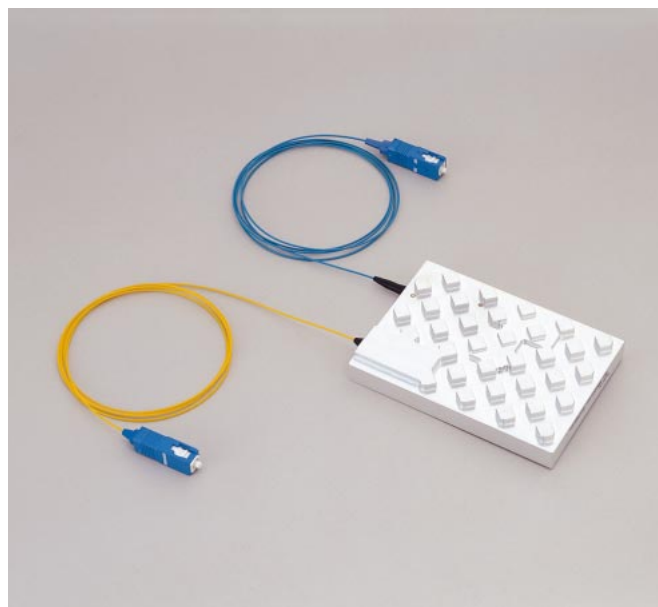

The highly-integrated and compact 10-Gbit/s transceiver module

The optical and electrical interface is compatible with the standard agreed to by the 9 MSA vendors including OpNext, Inc. The reductions of 55 % in volume and 40 % in power consumption were attained in comparison with the company's previous model.

## CP-X275W Micro-portable Multimedia Projector

The CP-X275W, which was released in Dec. 2001, has excellent qualities as a micro-portable projector, including:

(1) Super-wide-angle-lens projection: a 60" image from a distance of 1.5 m; (2) Quiet operation: 33 dB in whisper mode and 38 dB in standard mode; (3) Ultra-compact (W 289 × H 60 × D 210 mm) and ultra-light weight (2.4 kg); (4) Low price

Recent trend in liquid-crystal projector is characterized by two key expressions "brightness" and "resolution." The CP-X275W has been improved in brightness (1,200 lm) and in image resolution (compatible up to UXGA) to meet these market needs. The following features were also added to meet the needs of customers.

(1) Component-video input for HDTV  
 (2) Gamma correction: normal, cinema and dynamic mode  
 (3) Color-temperature correction: a new warm mode for DVD playback on a PC

(4) Illuminated buttons

(5) Direct keystone-correction button on the unit

CP-X275W succeeds the CP-X270W as our flagship model and will meet the various expectations that corporate, educational, and home users have with regard to presentation tools.



CP-X275W micro-portable multimedia projector

## Lineup of High-definition Plasma Televisions

Until recently, for plasma-display-panel (PDP) television and display screens to be light, and thin and to provide high brightness and a wide viewing angle, they had to be relatively large (i.e., 50 or 42 inches). In addition, such televisions and displays were mainly used in business. In 2001, however, all television manufacturers began full-scale production of plasma televisions for home use. Since then, many users have been enjoying the benefits of thin screens of plasma televisions whose market has been growing rapidly.

Acting as the driving force in creating plasma TVs, Hitachi became a world leader in producing plasma TVs in the spring of 2001 with the launch of its 32-inch plasma television (diagonal picture size: 82 cm). This model features a PDP based on the ALIS (alternate lighting of surfaces) technology for Hi-Vision broadcasting that has a 1,024-pixel vertical-line configuration. These features enable high-definition Hi-Vision images to be displayed on this new 32-inch PDP plasma television.

Since the launch of Hitachi's 32-inch visual-size plasma television in April 2001, the demand for plasma televisions has been growing rapidly. For example, in Japan sales of plasma TVs rose

from 5,000 units in the first quarter of 2001 to 10,000 units in the second quarter of 2001 with 65,000 units sold in 2001. The annual growth rate of sales for 2001 from 2000 was nearly 400%. This growth continues in 2002. The sales are now about 25,000 units, which is five times the number of units sold in the same quarter of 2001.

Hitachi started selling PDP TVs in the European market in the fall of 2001 and will expand its sales worldwide.



New lineup of high-definition plasma televisions (from the left: 32-inch visual-size, 37-inch visual-size, 42-inch visual-size)

## 37- and 42-inch High-definition Plasma Displays

The Hi-plasma CMP307X is the first 37-inch plasma display on the market to be compatible with the 1,024 × 768 pixel high-definition XGA\* format with a 4 : 3 aspect ratio. To suit the image being displayed, the CMP307X can be set for reproduction in either the 2.09 million-color mode for optimal sharpness and brightness, or the 16.77 million-color mode for superior picture quality.

The 42-inch Hi-plasma CMP4121HD also has a feature of reduced image retention for the display of still pictures. This model incorporates a 1,024 × 1,024 pixel high-resolution wide screen and a new panel that provides superior brightness for a breathtakingly crisp and bright picture with an extra-high white-peak brightness level of 750 cd/m<sup>2</sup>. Among the other technical advantages of this model are the application of black framing to ensure even blacker blacks, and a DCB (dynamic color balance) circuit that enhances the color balance at all levels of brightness.

All of this innovation makes the CMP4121HD a highly effective display for a host of applications.

\* XGA is a registered trademark of the International Business Machines Corp. in the U.S.

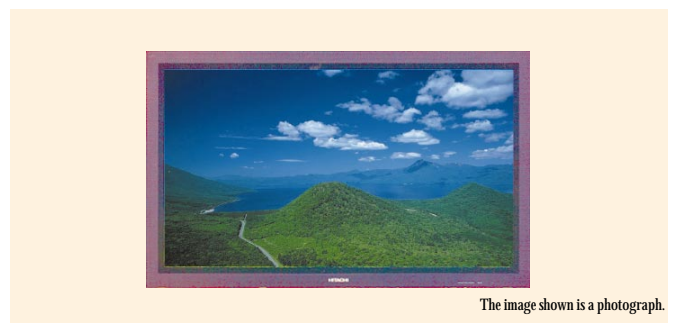

42-inch high-definition plasma display

The image shown is a photograph.

## Space-saving LSV40 40-inch Rear Projector

The LSV40 is an LCD-based rear projector that was developed for use in the display of digital information. There are two models: a ceiling-mounted display and a multi-display model. Either of these can be built into a large-screen display by connecting some units. The ceiling-mounted display is mounted above eye level. The screen is inclined 15-degrees downward because the images can be viewed easily and clearly when the display is mounted above eye level.

One of LSV40's many features is its space-saving design. The top depth of the ceiling-mounted unit is 550 mm and the bottom depth is 372 mm. The multi-display model's depth is 400 mm. These depths are less than half those of conventional CRT type projectors. The LSV40 produces a very bright image of excellent quality. This is because its black-stripe screen absorbs ambient light.

The LSV40 is thus suitable for a wide range of applications, such as the provision of information, advertisements, and promotional materials through broadband networks.



(a) 40-inch ceiling-mounted display array and a unit  
(b) 40-inch multi-display set and a unit

## New DVD-Cam: DZ-MV250, 270

Hitachi has announced its second round of DVD camcorders, the DZ-MV250 and DZ-MV270. A new feature of these models is that the user can record video onto 8-cm DVD-R discs. DVD-R discs hold up to 30 minutes of high-quality DVD video (per side). Although it is not rewritable, the DVD-R disc has a big advantage in that it may be played back on most standard consumer DVD players and DVD-ROM drives. Additionally, the new two models are capable of recording 1,998 JPEG still images at 1,280 × 960 pixels on DVD-RAM discs.

Consumers continue to receive the benefits of a disc-based system, including random access and the compact form factor. Random access to any point on the disc avoids clumsy rewinding and fast forwarding. Hitachi's DVD camcorders offer a visual "thumbnail" guide, i.e., a set of small pictures to representing the beginning of each scene recorded on the disc. Simply select the thumbnail picture to view the corresponding video clip. DVD-RAM offers the same capability for still images. Additionally, since the camcorders only write to empty areas on the disc, there is no danger of accidentally erasing any scene. With DVD-RAM, consumers can even edit their movies in the camera. This sophisticated system allows consumers to set up sequences and re-order them, and to add special scene-transition effects, including fades and wipes.

With PC that has a USB connection and Hitachi's optional PC-based editing software (DZ-WINPC3W), the DVD camcorders become external DVD-home-movie drives. Video can be transferred from the DVD camcorder to the PC for editing. After editing, the video can be transferred back to the DVD camcorder. This strong point of Hitachi's multi-format DVD camcorders gives consumers unprecedented capabilities.



DZ-MV250