

Electrical Components and Air-conditioning Units for Low-environmental-impact Trains for Subway Systems in China

Fang Shaoxuan
Zhu Baoquan
Yoshio Ohtomo
Toyoki Asada
Hirohisa Kimijima
Katsuhiko Fujii

OVERVIEW: Beijing — the capital city of China — is pushing ahead with the upgrading and development of the transportation-related equipment and facilities in time for the opening of the Beijing Olympics in 2008. A central core of these developments is improvements to Beijing's metropolitan railway network. Hitachi, Ltd. accepted bulk orders for and supplied complete sets of electrical equipment for the subway trains on the No. 5 Line of the Beijing Subway — the first subway constructed in accordance with the demands of the Chinese Government and the opening of the Beijing Olympics. We previously took charge of manufacturing of electrical equipment for the No. 13 Line, and the orders concerning the No. 5 Line were received thanks to the good appraisal of our products for the No. 13 Line.

INTRODUCTION

AS part of the attempts to reduce congestion concerning urban transportation and improve urban environments, underground train networks — aiming to fulfill orbital transit around cities — are being planned for each metropolitan area in China, and these networks are already being operated in several cities in addition to Beijing, Shanghai, and Tianjin.

At present, the metropolitan rail-transit network of Beijing consists of four lines: No. 1 Line (going east-

west through Tian'anmen Square), No. 2 Line (a central loop line), the Batong Line (continuing from the east end of Line No. 1), and No. 13 Line (joining academic areas in the northwest of the city with residential areas in the northeast).

Of the four new lines of the Beijing Subway — namely, the No. 4 Line, No. 10 Line, and Airport Line,

Beijing Subway construction plan map

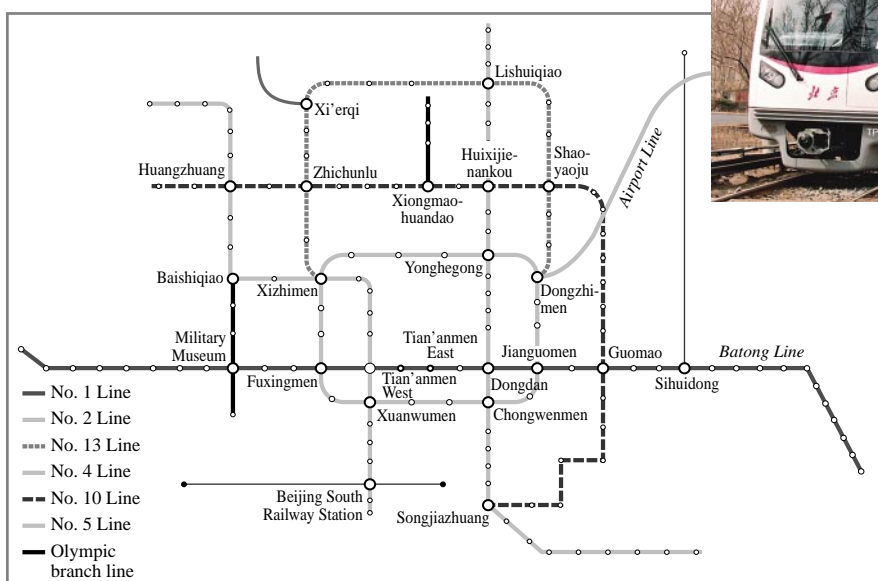

TP4000 Series for No. 5 Line of Beijing Subway



Fig. 1—External Appearance of Subway Train of No. 5 Line of the Beijing Subway and Map of Construction Plan for New Routes of Beijing Subway.

Hitachi is accepting batch orders for electrical products to be mounted on trains on No. 5 Line of Beijing subway. This is thanks to our favorable achievements implemented on No. 13 Line of the Beijing Subway.

in addition to the No. 5 Line (for which Hitachi, Ltd. received a job lot of orders) — now under construction in time for the opening of the Beijing Olympics, the No. 5 Line is the first to start commercial operation. In addition, since Hitachi was in charge of manufacturing the electrical equipment for the No. 13 Line trains, and the results of those manufacturing efforts were highly regarded, bulk orders for manufacturing the electrical equipment of the No. 5 Line trains were also received.

The subway trains of the No. 5 Line are six-car trains in a “3M3T” arrangement (where “M” stands for “motor” and “T” stands for “trailer”) and a total of 192 cars were manufactured.

The train (compartment body, bogies, and cabling) was designed by Changchun Railway Vehicles CO., LTD., who manufactured 126 cars, and 66 cars were manufactured by the Beijing Subway Rolling Stock Plant. Hitachi tendered to take charge of the VVVF (variable-voltage, variable-frequency) inverter equipment and traction motors, auxiliary power-source units, air-conditioning units, train-monitoring system, drive motors, and brake systems.

The rest of this report describes the technical details of the electrical equipment for the trains of the No. 5 Line of the Beijing Subway — which are set up for low environmental impact through improving energy saving, reducing maintenance work, and improving environmental friendliness.

OVERVIEW OF NO. 5 LINE OF THE BEIJING SUBWAY

Passing north-south through the center of the eastern part of Beijing, No. 5 Line of the Beijing Subway — with a total length of 27.6 km — includes 23 stations, starting from Songjiazhuang in Fengtai District in the south, passing through the commercial and embassy district on the east side of Old Beijing, and ending at Tian Tong Yuan Bei in the northern residential area of Changping District. Its underground section of 14.7 km (53% of the total length) incorporates 16 stations, and the rest of the line runs on elevated tracks over a distance of 12.9 km (47%) and incorporates seven stations. Connected to the storage tracks at Songjiazhuang and rail yards at Tai Ping Zuang, along its way from the south heading north, No. 5 Line intersects with No. 2 Line, No. 1 Line, No. 2 Line again, No. 10 Line, and finally No. 13 Line.

The planned routes for the Beijing Subway are shown in the left inset of Fig. 1. The No. 5 Line opened

for business on October 7, 2007, and its 192 cars are running smoothly without incident.

OVERVIEW OF SUBWAY TRAIN

An external view of a subway train of the No. 5 Line is shown in the photo in Fig. 1. Each subway train is composed of three types of car, that is, “Tc” (trailer car with cab), “M” (motor car), and “T” (trailer car). The main specifications of the cars are listed in Table 1, and the running performance of the train is listed in Table 2.

RUNNING PERFORMANCE OF SUBWAY TRAIN

The No. 5 Line trains are fitted with an AC (alternating current)-motor drivetrain (powered by a 750-V third-rail collector system) using VVVF inverters incorporating IGBTs (insulated-gate bipolar transistors). As regards the control technology for the drivetrain, speed-sensorless vector control and all-electric braking-control are adopted. This vector control technology improves response speed; as a result, regeneration ratio and adhesion performance are improved. Adopting the AC induction-motor drivetrain and VVVF inverter leads to improvements in energy saving, maintenance man-hours, and environmental friendliness. The configuration and characteristics of the drivetrain system are described in the following.

Construction

(1) The main circuit of the VVVF inverter unit consists of two groups of motors, with two motors controlled in parallel in each group, with power distributed in parallel to each group autonomously (that is, to drivetrain motors 1 and 3 in one group, and to drivetrain motors 2 and 4 in the other group).

(2) The inverter-control system — that is, a two-level-inverter method — runs two 180-kW induction motors in parallel. The main-circuit connections of the VVVF inverter unit are shown in Fig. 2, and the main specification is listed in Table 3.

Features

(1) Speed-sensorless vector control

Speed-sensorless vector control estimates speed from voltage and current, so it eliminates the need for sensors. As a result, maintenance of speed sensors is unnecessary, so the number of parts can be reduced and, in turn, the reliability of the whole train is improved. At the same time, applying vector control

TABLE 1. Main Train Specifications

Main train specifications for power supply, pantograph system, track gauge, compartment organization, etc. are listed.

Item number	Item	Content
1	Power supply/collector system	DC 750 V; third-rail collector
2	Gauge (mm)	1,435
3	Car organization	3M3T organization (Tc + M + T + M' + M' + Tc)
4	Car dimensions (mm)	Length: 19,000; width: 2,800; height: 3,800 Distance between bogies: 12,600
5	Riding capacity (persons)	Tc carriage: 226 (36 seated) M, M', and T: 243 (42 seated)
6	Design car weight (t)	Tc: 30; T: about 29; M and M': 35
7	Maximum speed	80 km/h
8	Bogie/gear wheel	“Bolsterless”-type pneumatic-spring bogies; drive train/teeth number ratio: 7.69; wheel diameter (newly manufactured)/770 mm (after maximum wear); axle gauge: 2,200 mm
9	Traction motor	180 kW squirrel-cage induction motor
10	VVVF inverter unit	PWM modulation-vector control 3-phase output IGBT/VVVF inverter control system Fitted with electric-power regeneration control (transformer-station power absorber and cooperative control) Control capacity: 1,400 kVA; main traction motor: 2 groups connected (1-3 and 2-4)
11	Control equipment	Power-regeneration/air-damping control system; fitted with skidding-control devices Electric-motor-driven air compressor: 720 L/min
12	Auxiliary power device	Capacity: 160 kVA; output: 380 V 3-phase 50 Hz
13	Car-monitoring equipment	Data collection/records presentation and auxiliary control functions; passenger-support function; maintenance-worker support function; ventilation equipment
14	Ventilation unit	25,000 kcal/h × 2 units per car
15	On-board equipment	ATO system; ATP system; on-board wireless radio communication

Tc: trailer car with cab VVVF: variable-voltage, variable-frequency ATO: automatic train operation
 M: motor car PWM: pulse-width modulation ATP: automatic train protection
 T: trailer car IGBT: insulated-gate bipolar transistor

TABLE 2. Train Operational Performance
Operational performance of the train (e.g. maximum operating speed and average operating speed) are listed.

Item number	Item	Content
1	Maximum operating speed	80 km/h
2	Average operating speed	50 km/h (typical zones; not including stopping times at stations)
3	Scheduled speed	36 km/h (stop time at stations: 30 s)
4	Average acceleration	0 – 40 km/h at 0.83 m/s ² 0 – 80 km/h at 0.5 m/s ²
5	Average deceleration	80 – 0 km/h Regular maximum braking: 1.0 m/s ² Rapid braking: 1.2 m/s ² Emergency braking: 1.2 m/s ²
6	Jerk capacity	Less than 0.75 m/s ² (excluding during emergency braking and main-circuit protection operation)

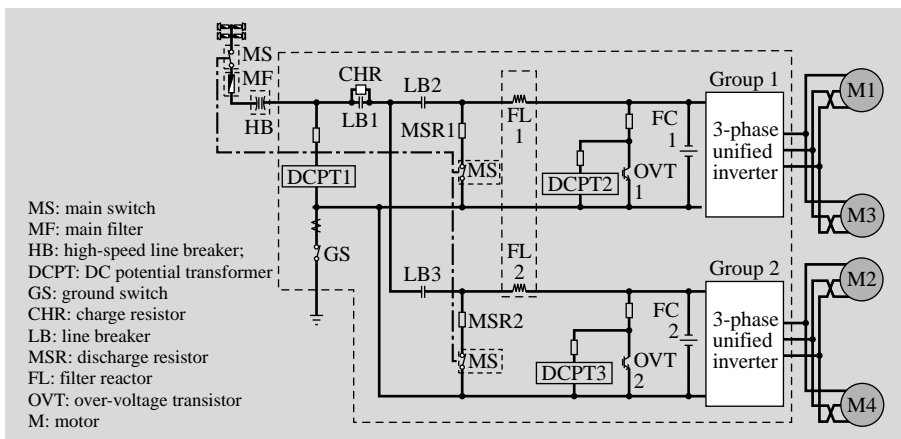

Fig. 2—Overview of Main Circuit of VVVF Inverter Circuit.
 The main circuit system consists of two groups of systems each with two-motor parallel control.

TABLE 3. Specifications of the VVVF Inverter
The main specifications of the VVVF inverter (devices, control system, etc.) are listed.

Item	Specification
Utilized device	IGBT device
Control system	<ul style="list-style-type: none"> • Three-phase-voltage two-level PWM modulation inverter • All-electric braking control • Speed sensorless vector control
Traction motor	<ul style="list-style-type: none"> • Two three-phase 180-kW induction motor units in parallel \times two connected groups • Compact, lightweight filterless/rotational speed sensorless
Inverter output capacity	1,400 kVA (max. 724 kVA \times 2 groups)
Operation command signal	PWM modulation signal
Cooling system	Natural cooling (reduced number of parts; reduced maintenance/ improved reliability)

improves control precision; consequently, response speed of the electric-motor control is increased, and the adhesion utilization ratio of the wheels can be exploited to the very limit.

(2) All-electric braking control

Aiming to improve ride quality when the train is decelerating during braking and reduce brake nose noise, all-electric braking control is adopted. This control system can control braking all-electrically to the point that the train is on the verge of a complete stop, and electric braking can be operated until the verge of stopping. If the braking force is insufficient or invalid, the electric braking is supplemented by auxiliary pneumatic brakes or, if that is not sufficient, the pneumatic brakes take over completely. The electric brakes and the pneumatic brakes smoothly switchover automatically with a minimum of jerk. As a consequence of this braking system, wear of the brake shoes on the wheels is reduced, and the role of the electric-power regenerative brakes (for economization of power consumption) is enhanced.

(3) Maintainability

The inverter unit has “longitudinal box-type” structure (i.e. “long” in the lengthwise direction of the cars) so that it can be accessed from one side of the train. As for the inverter unit, circuit breakers are built-in, so the amount of wiring fitting-out is reduced, and the terminals for the TMS (train monitor system) are also built-in. As a result of this configuration, the amount of wiring work for the inverter and TMS



Fig. 3—External View of VVVF Inverter.
The inverter is configured as a “longitudinal-box construction” so it can be handled from the side of the car body.

equipment is reduced, the inverter unit is more compact owing to its box-like configuration, and maintainability is improved by placing the logic units and TMS terminals close to each other. An external view of the inverter is shown in Fig. 3.

(4) PWM operation command signal

The signaling for operation commands utilizes PWM (pulse-width modulation), so command-signal reliability is improved, and the amount of cable fitting for the command lines is reduced. An analog voltage signal is output from the master controller, that signal is converted to a PWM signal by an encoder unit, and the PWM signal is sent to the VVVF inverter and brake equipment. Furthermore, in addition to the analog signal, the encoder unit can receive digital signals from the main controller unit, ATO (automatic train operation) unit, and braking equipment, and can switch between three kinds of operation mode: (a) manual operation by master controller, (b) ATO operation, and (c) railway-train forwarding-hauling operation

Auxiliary Electric-power Systems

The auxiliary electric-power system is used for the power source for controlling each train system (i.e. air-conditioning units, heater units, lighting, and battery chargers), and for the power sources for the train-monitoring system, on-board signaling equipment, and communication equipment. The construction and features of the system are described in the following sub-sections.

(1) Construction

The main-circuit system of the auxiliary electric-power system adopts IGBT devices in a high-speed circuit breaker, and is composed of a DC (direct-current) filter circuit, a power unit, an AC filter circuit, and a transformer. And it applies two-level inverter control to provide an output capacity of 160 kVA. Voltages of DC 110 V and DC 24 V are rectified from AC 380 V by AC/DC conversion. An external view of the auxiliary electric-power system and its main

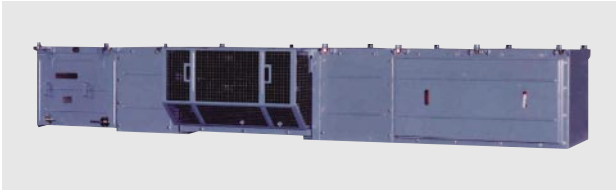

Fig. 4—External View of Auxiliary Power Unit.
Since a three-phase output line is connected full-time, even in the case that one of the auxiliary power-supply units stops, the power is not cut off to any of the cars.

TABLE 4. Specifications of Auxiliary Power-supply Unit
The main specifications of auxiliary power-supply unit (output voltage, inverter output capacity, etc.) are listed below.

Item	Specification
Output voltage	AC 380 V, 3-phase, 50 Hz, DC 110 V, DC 24 V
Inverter output capacity	160 kVA
Control system	Three-phase-voltage two-level PWM inverter Parallel operation system
High-speed breaker unit	IGBT device is used.
Cooling system	Natural cooling (reduced number of parts; reduced maintenance/improved reliability)

specification are given in Fig. 4 and Table 4, respectively.

(2) Features

(a) Connected in parallel, the auxiliary electric-power units employ a parallel-running control method for feeding power. Accordingly, since a three-phase power-output line is always connected by means of this in-parallel running control, in the case that one auxiliary unit is shutdown, none of the power supplies to any of the cars is cut-off. That is to say, even in the case that DC input of the auxiliary power-supply units on one side is cut-off when the train passes a section of the third rail, stable power supply to the whole train is maintained. The schematic configuration of the auxiliary power-supply system is shown in Fig. 5.

(b) In the case that two static-type inverters are in a normal state, one static-type inverter transmits load-assignment information between the two static inverters, and the optimum power supply for a particular load is supplied. In the case that one static-type inverter breaks down, the other inverter (still in normal mode) takes on the power-supply load for the six-train configuration. At that time, the load of the

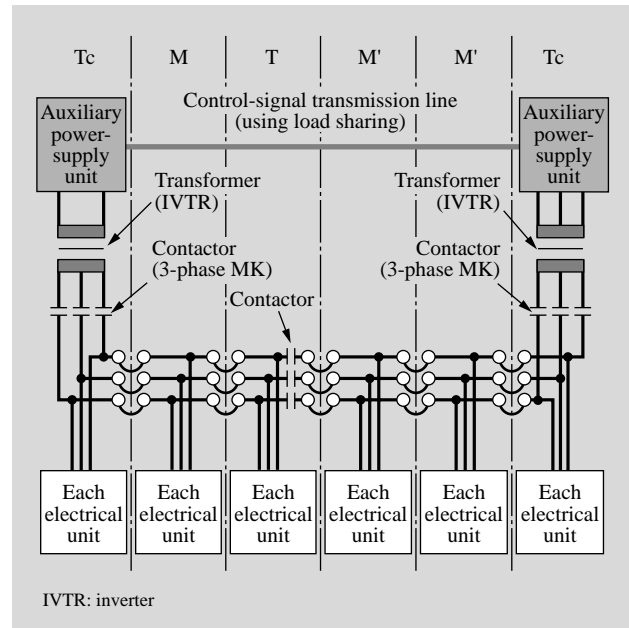

Fig. 5—System Configuration of Auxiliary Power-supply Unit.
The system configuration of auxiliary power-supply unit (used for supplying air-conditioning units, car-monitoring units, in-car signaling units, communication devices, etc.) is shown.

air-conditioning unit is reduced by half. Utilizing IGBT devices for the IVHB (inverter high-speed breaker) and fitting the IVHB inside the auxiliary power-supply system makes the system more compact and reduces its weight.

TRAIN-MONITORING SYSTEM

As well as collecting, recording, and presenting information, the train-monitoring system is a highly functional type providing functions such as auxiliary control of air-conditioners. By bolstering the train-crew support functions and maintenance-support functions along with the standard functions, the efficiency of train operation and maintenance is improved. In regard to operation state and failures of the main train equipment, data is collected, recorded, and presented automatically. The data is readout from various readout devices, and the results can be printed out.

(1) Configuration

The train-monitoring system is composed of a touch-sensitive, color LCD (liquid crystal display) panel in the driver's cabin, central monitoring units mounted in rectifiers in Tc cars, VVVF inverters in T and M cars and monitoring-station units equipped in the power-receive/supply equipment. These devices are connected by a backbone transmission channel at a bit rate of 2.5 Mbits/s. The backbone

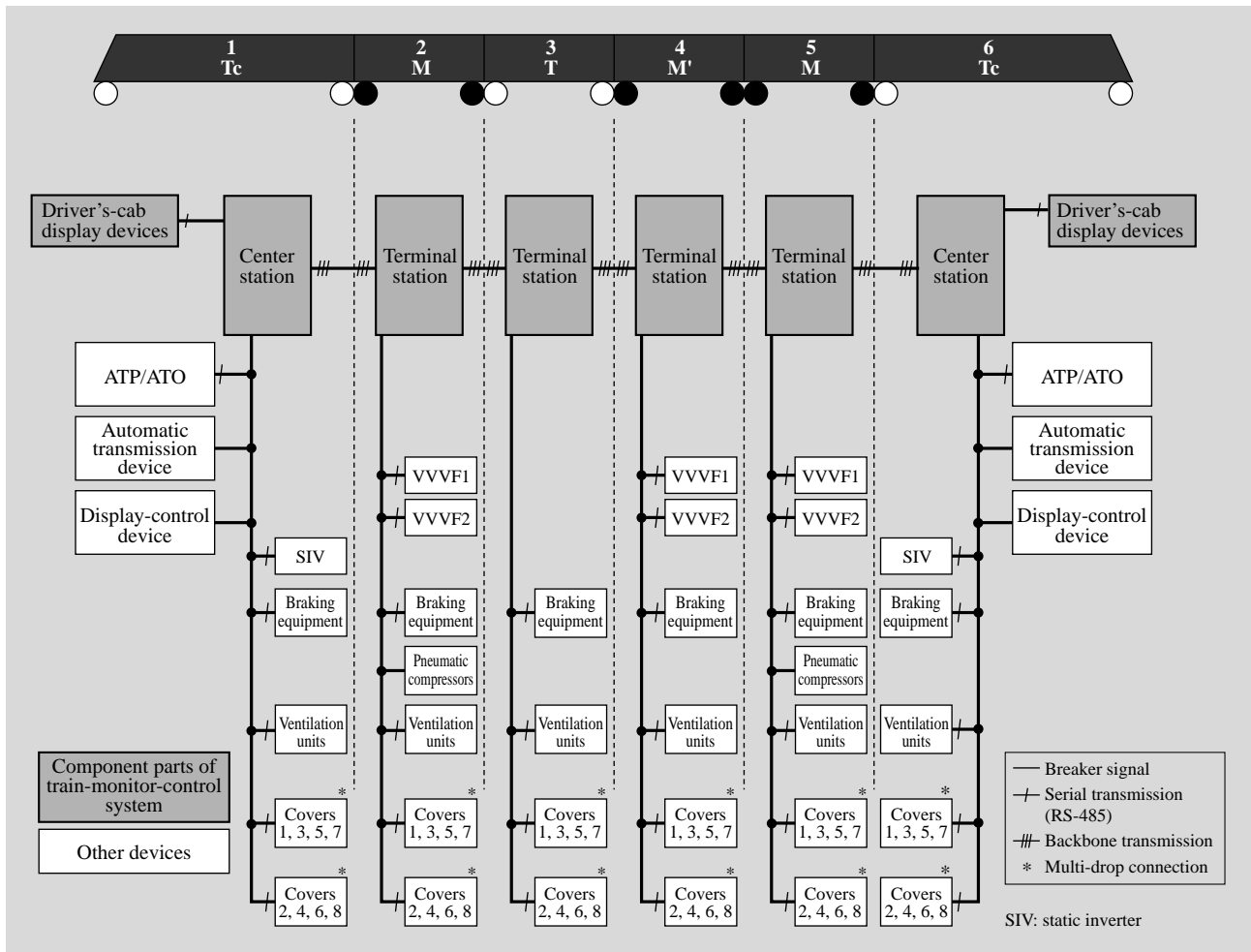

Fig. 6—Configuration of Car-monitoring System.

The car-monitoring system is composed of driver's-cab display devices, monitoring devices at the center of car Tc, and VVVF inverters in M and T cars as well as monitoring terminals fitted in receiving/feeder devices.

transmission employs the ARCNET (attached resource computer network) protocol, resulting in compact circuitry and a high-reliability transmission channel. Each central station and terminal station have RS-485 serial transmission interfaces, so two-way communication between each equipped device (such as inverters, brake units, and air-conditioners) is possible. The transmission protocol complies with the HDLC (high-level data link control), so international serial communication with each device is accomplished. Moreover, the capturing of the signals on each cabling line for each car is done via parallel interface. The configuration of the train-monitoring system is shown schematically in Fig. 6.

(2) Performance and features

(a) Inspection on departure (such as checking opening and closing of doors, train start-up, and braking) can be carried out before the train leaves the rail yard. And

the principle status of the train can be displayed.

(b) Self-diagnosis functions automatically check-out the train on start-up, and the diagnosis results are displayed on monitors.

(c) There are functions for supporting train-crew work, and in addition to functions for displaying train information for drivers in the conventional manner, there is a "work sign display function" for displaying work information (i.e. operating schedule information) concerning the train. There is also a function for supporting crew duties such as displaying train status, setting of terminal station and present station, displaying failure/fault information and displaying processing commands and traveling-plan information, and setting of cooling and heating temperature of the air-conditioning system.

(d) There is a maintenance-support function for executing test-run measurements and recording of fault



Fig. 7—Examples of TMS Driver's Cabin Displays. Displays of (a) work information, (b) malfunctions, and (c) fault records are shown.

information. In addition to conventional equipment-monitor display functions, the train-monitoring system has a running-data recording function for periodically recording operation data concerning train equipment and car bodies, a measurement-recording function for recording distance-traveled data and power consumption of SIVs (static inverters), and power-running and regenerative power of VVVF inverters, and a test-running function for measuring braking distance, acceleration, and deceleration. As a result of these functions, the user-friendliness of maintenance is improved. Moreover, functions for performing on-board checks — such as checking door opening/closing, braking, air-compressors, and self-diagnosis — are also provided (see Fig. 7).

AIR-CONDITIONING EQUIPMENT

The air-conditioning equipment is attached to the roof of the cars, and to set it within the train gauge, slim-type air-conditioning units are adopted. The air-conditioning units have a cooling performance of 50,000 kcal/h per car, provided by two units per car (i.e., cooling performance of 25,000 kcal/h per unit), and one unit is fitted on the roof at each end of each car. An external view of an air-conditioning unit is shown in Fig. 8.

Three sets of refrigeration cycles are included in each air-conditioning unit, and these three sets share one evaporator unit. As a result, there are four control levels for the cooling: strong (100%), medium (66%), weak (33%), and air-blower. This is one more level than conventionally available, so finer control of optimum air temperature and energy saving can be expected.



Fig. 8—External Appearance of Air-conditioning Unit. Since the unit is fitted within the boundary of the train car, a low-profile air-conditioning unit could be adopted.

CONCLUSIONS

This report described the technical features of the electrical components of a subway train that aims to meet demands such as energy saving and good maintainability, improvement of environmental friendliness, and low environmental load.

A prototype with a two-car organization of the TP4000 Series train of the No. 5 Line of the Beijing Subway was completed in April 2006, and running trials of the train by Changchun Railway Vehicles CO., LTD. between April and May that year confirmed the basic performance of the prototype. And from March to April, 2007, final verification trials on the main line were executed, and predefined performance was confirmed. After that, on October 7 that year, commercial operation of the No. 5 Beijing Subway Line started.

Continuing on from our work on the No. 13 Line

of the Beijing Subway, Hitachi, Ltd. has supplied several electrical products for the cars of the No. 5 Line. It is anticipated that these electrical products will make significant contributions to the success of passenger transit during the Beijing Olympics in August 2008 and further development of train transportation in Beijing City.

ACKNOWLEDGMENTS

In conclusion, on the implementation of the subway trains for the No. 5 Line of the Beijing Subway, we sincerely thank all those concerned at Beijing Mass Transit Railway Construction Administration Corp., the Beijing MTR Operation Corp., and Changchun Railway Vehicles CO., LTD. (which played a

coordinating role in the construction of the whole train).

REFERENCES

- (1) S. Fang et al., "Overview of the TP4000 Series Train of the No. 5 Line of the Beijing Subway," (two volumes) *Railway Vehicles and Technology*, Nos. 124, 125, January and February 2007.
- (2) T. Sekizawa, et al., "Electrical Product Systems for the No. 5 Line of the Beijing Subway," *Railway Cybernetics*, 2006 paper.
- (3) S. Ito, et al., "TMS Systems of the No. 5 Line of the Beijing Subway," *Railway Cybernetics*, 2006 paper.
- (4) S. Fang et al., "Overview of the H4000 Series Train for the No. 13 Line of the Beijing Subway," *Railway Vehicles and Technology*, January 2004.

ABOUT THE AUTHORS



Fang Shaoxuan
Vice Process Engineer, Equipment Department, Beijing MTR Construction Administration Corp.



Zhu Baoquan
No. 5 Line Project Manager, Senior Process Engineer, Equipment Department, Beijing MTR Construction Administration Corp.



Yoshio Ohtomo
Joined Hitachi Plant Engineering Co., Ltd. (now Hitachi Plant Technologies, Ltd.) in 1979, and now works at the Overseas Operation Department (China), the Rolling Stock Systems Division, the Transportation Systems Division, the Industrial Systems, Hitachi, Ltd. He is currently engaged in rolling stock systems engineering. Mr. Ohtomo is a member of the Japan Society of Mechanical Engineers (JSME).



Toyoki Asada
Joined Hitachi, Ltd. in 1992, and now works at the Rolling Stock Electrical System Design Department, the Mito Transportation Systems Product Division, the Transportation Systems Division, the Industrial Systems. He is currently engaged in railway electrical traction system engineering.



Hirohisa Kimijima
Joined Hitachi, Ltd. in 2000, and now works at the Rolling Stock Electrical System Design Department, the Mito Transportation Systems Product Division, the Transportation Systems Division, the Industrial Systems. He is currently engaged in rolling stock control and monitoring system engineering.



Katsuhiko Fujii
Joined Hitachi, Ltd. in 1999, and now works at the Electrical Machinery System and Plant Construction Engineering Department, the Hitachi Works, the Power Systems. He is currently engaged in rolling stock motor design.