

Development of Advanced RFID Application Systems for Nuclear Power Plants

Kimiharu Onda
Keiro Muro
Eisuke Wakabayashi
Ryosuke Shigemi
Ryota Arai
Shinya Yuda

OVERVIEW: In regard to manufacturing control of components for nuclear power plants as well as construction and maintenance of such plants, “traceability” of information such as construction records and work records has become even more strongly required over recent years. Meanwhile, RFID technology (which identifies people and products in mass-production industries by means of radiowaves) is used as a basic technology for supporting the “ubiquitous information society,” and its functionality and versatility are improving all the time. With this background in mind, the Hitachi Group has developed systems that apply RFID technologies to manufacturing control of pipe fabrication and construction management of nuclear power plants in order to improve quality and reliability of such plants, and the implementation of these RFID technologies is continuing to show effective results.

INTRODUCTION

A nuclear power plant is composed of a huge amount of different components (more than a million). As for construction and maintenance of such a plant, “information traceability” regarding components, construction records, used tooling, and so on is strictly enforced. Conventionally, checking and inputting of these records are mainly done by workers by manual input and visual verification. It has, however, become necessary to do “double checks” to avoid human errors like transcript errors.

In the meantime, RFID (radio-frequency identification) technology — which is rapidly gaining popularity in the industrial area as an automatic-recognition method because of its high level of functionality, general versatility, and environmental resistance — is drawing much attention. RFID technology recognizes IDs (identifications) by using electromagnetic waves (i.e. radiowaves), so it can recognize an ID without it being directly in sight. Furthermore, in contrast with a bar code (which is an equivalent automatic-recognition method), RFID technology features higher general versatility owing to its robustness against dirt and friction. With this background in mind, the Hitachi Group has been promoting technological development through application of RFID technology to construction and maintenance of nuclear power plants.

The rest of this report describes Hitachi’s production control and construction management as well as systems that apply RFID technology for maintenance (see Fig. 1).

APPLICATION TO PIPING-PRODUCTION CONTROL TECHNOLOGY

In regard to work-record monitoring and welding-record control on production lines in piping manufacturing plants as well as shipping control of manufactured piping, practical application of RFID technology has begun.

Application to Work-record Monitoring

The shape of each manufactured piping for nuclear power plants, amounting to several tens of thousands of items, is different from other pipings, and it is a risk that trouble in the manufacturing process will delay on-site construction progress of a plant. This means that delivery-date management of each piping item is necessary. Moreover, the piping-manufacturing process includes many steps after materials are input (for example, cutting, bending, and welding); accordingly, it is necessary to control an enormous amount of work records in conjunction with these process steps.

Up until now, a day-to-day production plan is devised by our in-house-developed production-control

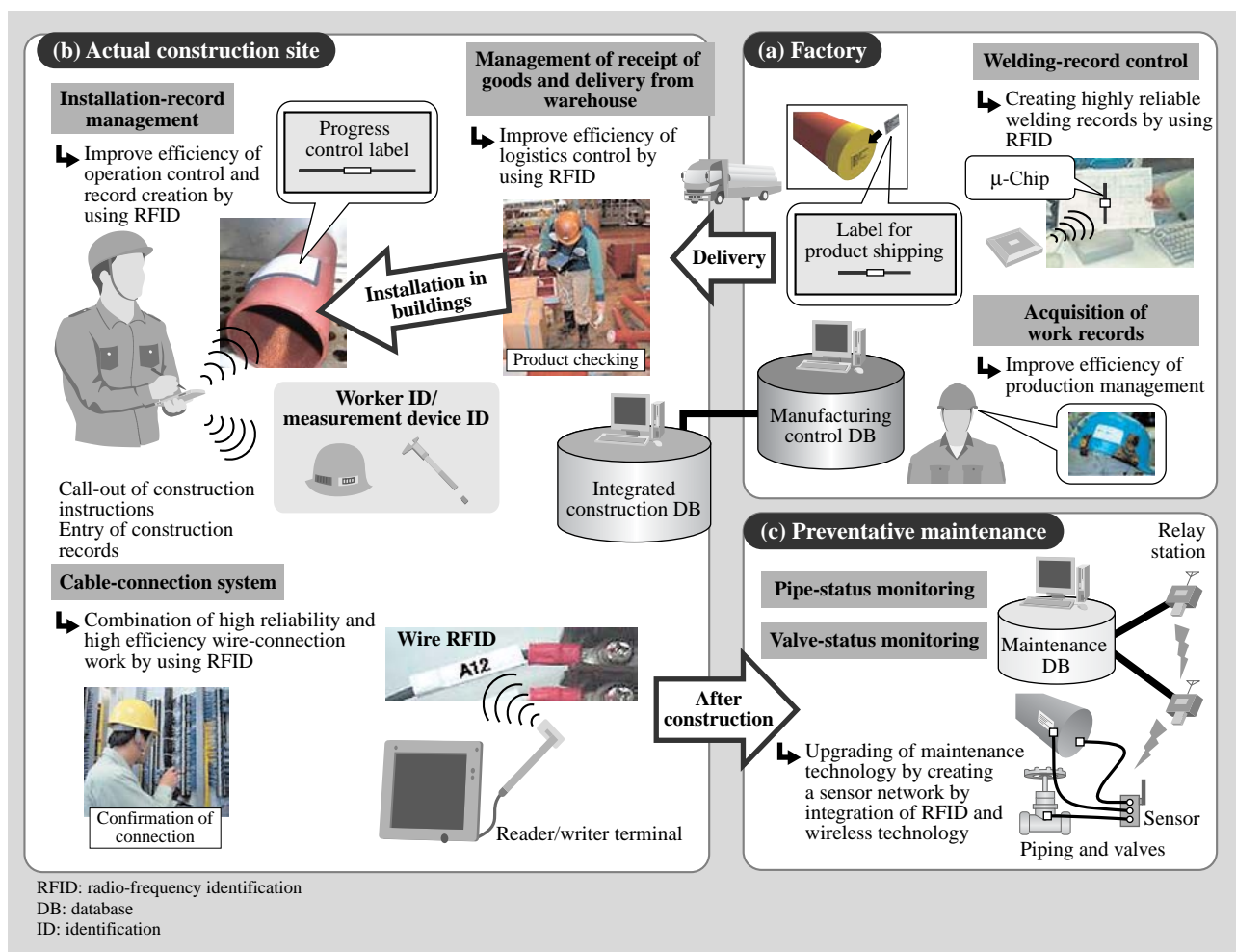

Fig. 1—Actual Expansion into Technologies for Production Control, Construction, and Maintenance in Nuclear Power Plants.

Examples of applications to (a) welding-record control in pipe-manufacturing plants, (b) product-material management at construction sites as well as installation-work support and cable connection, and (c) status monitoring in nuclear power plants.

system, and the past performance data for each process in the plan are input manually into the system. Naturally, real-time control is difficult under these circumstances. Given that fact, we have developed a system that uses RFID technology to improve the collection method and control of work records. The features of this system are described in the following sections.

In the piping manufacturing process, operations are carried out with IC (integrated circuit) tags built into the work records that are generated for each manufactured item. Thereupon, by making it possible to read IC-tag-attached manufacturing form by RFID readers set up at each production process at the start and finish of a work operation, it is possible to import data such as start and finish times of each process into

a manufacturing-control database. Furthermore, this system can be hooked up to conventional manufacturing-control systems, and production progress and delay status of each piping product can be verified in real time. In addition, by prescribing the timing of the start and finish of a process, it is possible to systematically estimate lead times and performance of each process step, leading to on-site improvements and higher production efficiency (see Fig. 2).

Application to Welding-record Control

On top of plant safety and quality control, assuring soundness of welded parts is vital. Accordingly, it is necessary to implement rigorous “qualification control” for enforcing proper welding by a welder with suitable qualifications. Furthermore, it is necessary to

keep more detailed records in comparison to those for other work, so a tremendous amount of effort is needed for qualification control and record management.

Given those circumstances, in regard to welding work, we have applied RFID technology to welder

tags, welding rods, and so on in addition to applying it to manufacturing form. By getting the welder to scan the aforementioned IC tag with a PDA (personal digital assistant) with a built-in IC-tag reader before starting a welding operation, the information required for qualification control can be verified against registered information in a qualification-control database.

In this way, it is possible to verify, for example, whether a welder has the necessary qualifications for welding relevant parts to be welded or whether the welding conditions are as instructed. Consequently, it is possible to prevent improper welding operations before they are performed. In addition, records such as welding current can be stored as electronic data after welding is complete, so operating efficiency of record organization and verification of welding work can be dramatically improved (see Fig. 3).

Application to Shipping Control

As mentioned above, incorrect or delayed shipment of pipes and their accompanying parts triggers delays at the construction site of a power plant. Product-shipment control is therefore extremely important. Conventionally, at the time of product shipment, the finished product is verified against a paper letter of transmittal by visual checking. As a result of this procedure, a huge amount of work is needed to check finished products and prevent human errors.

As for the system developed in the current work,

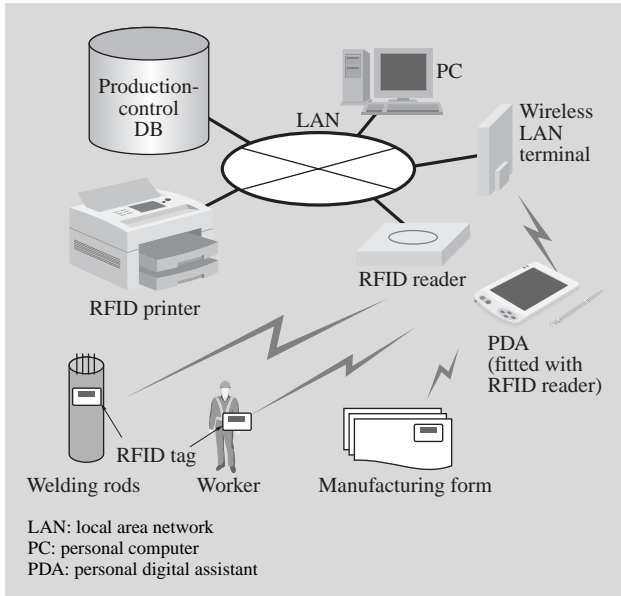

Fig. 2—Configuration of RFID System and Piping Factory. A system applying RFID technology is composed of RFID tags fixed to welding rods, operators, and manufacturing form targeted for control, readers for identifying the RFID tags, PDAs for recording data, a wireless LAN, and a database for managing the data.

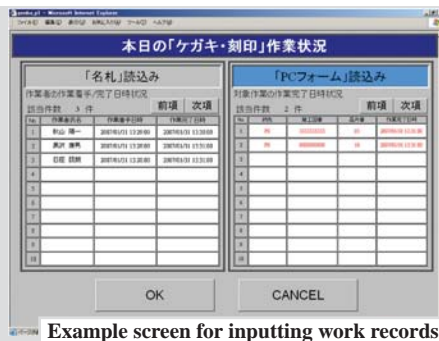

Fig. 3—Examples of Scenes of Workers Using RFID Technology and a Work Input Screen at Pipe-production Plant. RFID technology is applied to work-record collection and welding control as well as shipment control of piping.

by simply scanning the IC tag fixed to piping products with a PDA before shipping, it is possible to automatically verify the scanned data against the shipping-schedule information designated by the manufacturing-control system.

Moreover, a letter of transmittal can be automatically generated through connection with the production-control database, contributing to a reduction in the amount of effort exerted in all shipping work. And shipping information registered in the system can be instantly sent to the construction site due to receive the piping freight, enabling sure-and-steady delivery-date control between the manufacturing plant and construction site.

APPLICATION TO ON-SITE CONSTRUCTION MANAGEMENT

In regard to product receipt and warehouse-delivery control, and installation-work record control as well as cable-connection work at the actual construction site, systems using RFID technology have started to be applied.

Application to Product Shipment and Warehouse Delivery

In regard to receipt of products such as piping at the construction site, product verification is conventionally performed by visually inspecting the presented letter of transmittal of the originally dispatched product and checking it against the received product. Then, a huge amount of records have to be manually input into the product-control system on returning to the administration office.

Consequently, a lot of effort is involved in preventing human errors like verification errors and transcript errors at the construction site. Given those circumstances, we have developed a system using RFID technology for receipt of products and warehouse control at the construction site. The features of the system are described as follows.

By means of the developed system, product-shipment information sent via the system from the factory and the IC tags attached to the products are checked off against each other. The checking results are automatically registered in the construction-management system and controlled on the system as past records of receipt of products. Moreover, inventory location and workers' names stored on the product can also be input by IC tag, so the accuracy of information concerning receipt of products and delivery control at the construction site can be

improved. By simplifying verification work and data input operations by using RFID technology in this way, it has become possible to reduce the amount of work performed by administrators and workers alike. On top of that, it is often the case that received products are first stored in a warehouse and delivered in accordance with the construction-site installation schedule. The new system is also applied for controlling this process, thereby reducing the burden on workers.

At the time of selecting an IC tag attached to a piping product, a mock-up that takes account of the actual environment at the construction site is implemented, and the one that possesses durability characteristics such as resistance to dust, rain drops, friction, and heat is selected.

Application to Installation-record Management

As regards a construction site of a nuclear power plant, in the case of the installation of piping, for example, it is necessary to identify welding locations spanning more than 40,000 points. Moreover, welding work is performed in accordance with welding instructions generated for each welding point. The installation-work records are input into the system manually, so a huge amount of effort is needed to prevent human errors. Given that fact, to improve reliability of records and to alleviate the load on workers, we developed a system that applies RFID technology. The features of the system are described as follows.

Through the on-site installation work-record support system, IC-tag information and work-instruction information are connected. As a result of this connection, by scanning IC tags at the construction site with an IC-tag-reader-fitted PDA, work instructions can be displayed on the PDA, and the record of that work can be directly input at the site. Moreover, data acquired by measurement devices used in operations by workers or inspectors can be automatically input via the IC tags, contributing to further reduction in human errors. Using RFID technology to draw up construction records in this manner makes it possible to improve the reliability of creating records on site and to reduce the load on workers.

Generally, in the case of piping-installation work, pipes are inspected before welding to check whether foreign matter has got into pipes. As for drawing up records of the inspection work, conventionally, a card registering information about the inspector's name and

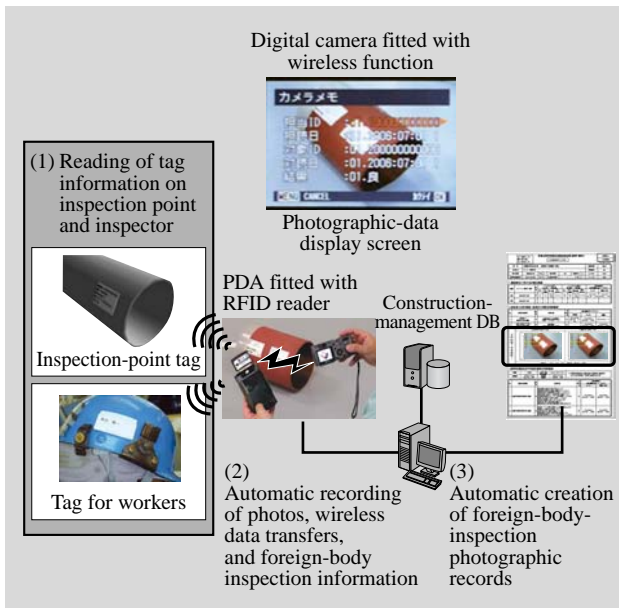

Fig. 4—Overview of RFID Application to Foreign-body Inspection in Piping Factory. Photographic data from foreign-body inspection and film information (photographed place, person who took photo, and day photo was taken) are input and linked by RFID, and records are created automatically by construction system.

pipng inspection point is photographed alongside the inspected region of the pipe. These photographic records are manually organized at the administration office. A consequence of this procedure is that a great deal of work is done in creating and managing these records. With the drawback in mind, we developed a system using RFID technology to handle such work as well.

With this system, which uses a special camera, after the ID of the targeted inspection point and ID of the photographer are scanned, the target point is photographed. The inspection result (that is, photographic-image data) is then automatically linked to the IC tag data. This image data is then registered in the construction-management system. At that time, the IC-tag information is linked to the welding-point work record as a key, and a “foreign-material inspection record” is created automatically. In this manner, it becomes possible to improve the reliability of foreign-material inspection records and reduce the workload involved in human-error prevention and control (see Fig. 4).

Application to Cable-connection Work

Cabling installation in nuclear power plants involves a huge amount of cables (namely, over

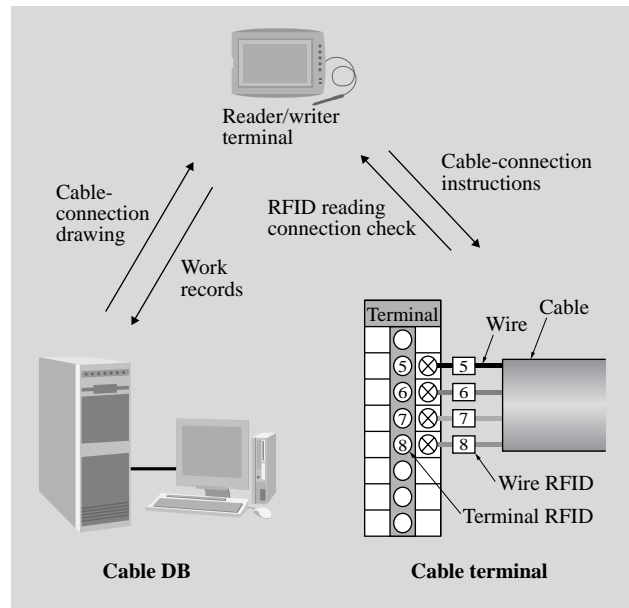

Fig. 5—Overview of RFID Cable-connection System. The wire-connection navigation system is composed of a wire RFID and terminal RFIDs as well as a reader/writer terminal for checking connections and a cable database for managing data.

20,000). The connection-work procedure for this huge amount of cables consists of the following consecutive steps: issuing a cable-connection drawing at the on-site administration office, connecting the cables on site, checking the connections, and inputting performance results back at the on-site administration office. Regarding this cable connection, the code tag is attached to the core wires in accordance with the cable-connection drawing so that it can be recognized and, therefore, improper connections can be prevented. Two major points of concern associated with this conventional cable-connection procedure — that is, one, the workload expended on controlling issuance of cable-connection drawings at the on-site office and inputting performance records and, two, the risk of improper connection of cables on site — are often cited. Given those issues, we have developed an “RFID cable-connection system” for alleviating that workload and eliminating cable-connection errors.

A schematic overview of the RFID cable-connection system is given in Fig. 5. The RFID cable-connection system is composed of IC tags (terminal RFIDs) fixed to terminals and IC tags (wire RFIDs) fixed to wire cables, a reader/writer terminal for reading these tags and displaying the cable-connection drawing, and a cable database for controlling the work

records and cable-connection drawing. The database makes it easy to control the issuance of cable-connection drawing at the work site easily. Moreover, scanning the IC tags on site with the reader/writer terminal and checking the cable connection on the spot makes it possible to simplify the work-records control

and lighten workloads.

As for this RFID cable-connection system, connections are judged to be correct or not by means of automatic verification of the wire RFIDs and terminal RFIDs against the cable-connection drawing, that judgment result is displayed on the reader/writer terminal, and improper connections are thereby prevented (see Fig. 6).

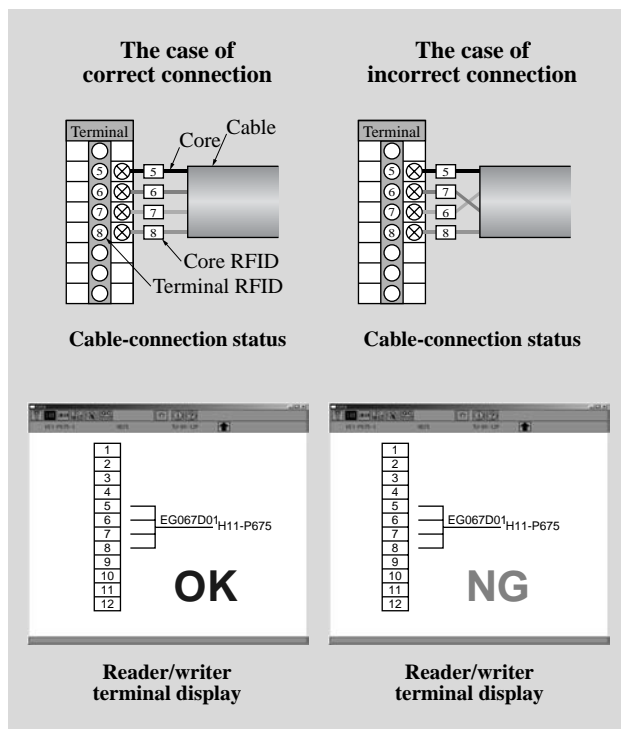

Fig. 6—Function to Prevent Incorrect Connection. By reader/writer terminal, cable-connection drawing read by the wire RFIDs and terminal RFIDs and connection errors in it are determined by automatic checking, and the results are displayed on the reader/writer terminal.

APPLICATION TO EQUIPMENT-STATUS MONITORING

As for safely operating a nuclear power plant full-time, in addition to carrying out preventative maintenance, determining how to raise utilization efficiency is important. In light of that consideration, from now onwards, CBM (condition-based maintenance) — which involves full-time monitoring of deterioration conditions during plant operation and carrying out maintenance with the right methods for the right equipment at the right time — is being considered ever more important.

At Hitachi, for the purpose of establishing a “condition-based maintenance system for energy plants” using sensor networks⁽⁵⁾ (see Fig. 7), we have developed “sensor nodes” fitted with vibration sensors. We have completed transmission-verification tests on-site and expect to apply the system to actual machinery in the near future.

A sensor network is a technology that deploys monitoring network by interconnecting multiple compact battery-powered sensors via redundant pathways composed from multiple wireless repeaters. Since power supplies and transmission lines are

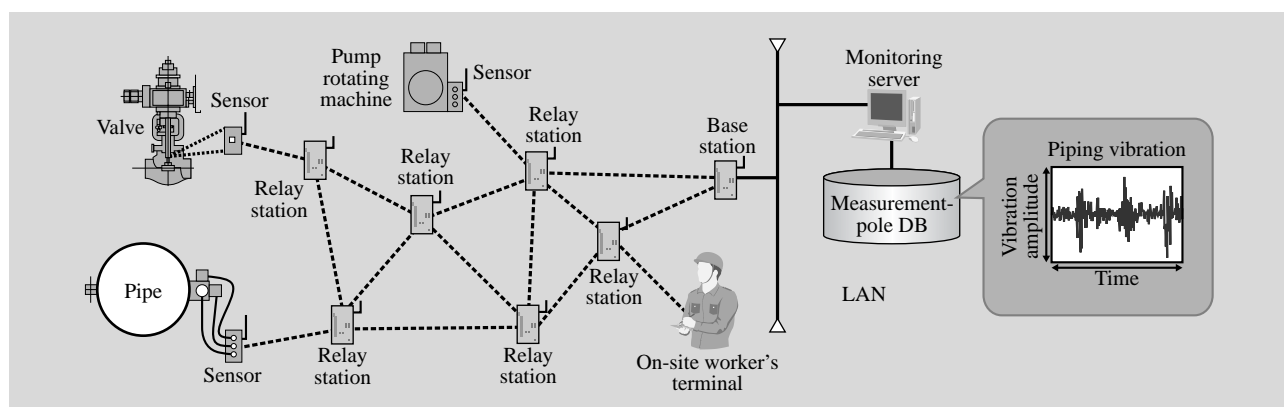

Fig. 7—Example Configuration of Plant-status Basic-maintenance System. Status measurements (on valves, pipes, etc.) are sent to a monitoring server via redundant pathways configured from multiple wireless relay stations, and malfunction/abnormality detection and degradation measurements are performed.

unnecessary, the flexibility of installation location is improved, and all-time monitoring of multiple monitoring points at low implementation costs (compared to conventional wired-sensor monitoring systems) is possible. This system can perform auditing control under normal conditions as well as detection and rapid issuance of warning signals during anomalous occurrences. In this way, for example, after the occurrence of an earthquake, the status of piping and valves during an earthquake can be understood, and planning of inspection and maintenance can be quickly drawn up; accordingly, secondary accidents can be prevented. Moreover, the system can forecast deterioration status of valves and pipes during pipe operation and, at appropriate times, can provide planning proposals for the equipment and locations needing inspection.

Positioning sensor networks as a common infrastructure and aiming to upgrade maintenance, Hitachi is applying sensor networks to status monitoring of various equipment and collection of testing data.

FUTURE VISION FOR RFID APPLICATIONS

Up until now, we have achieved verification of products and welding qualifications as well as improved reliability and efficiency of construction and utilization-measurement devices and input of work records by means of authenticating IC tags and recalling information restricted to IC tags by accessing the database. From now onwards, improving transmission performance of RFID technology in leaps and bounds will be a certainty, and control methods applicable to different kinds of RFID devices will be invented. In line with these trends of the times, the concept of RFID that we are assuming is the connection between physical objects existing in the real world and objects in the virtual world (as represented by computer networks). The role of RFID technology in the future is expected to be further reduction of energy consumed in information acquisition from work sites, which conventionally experiences heavy loads (see Fig. 8). While continuing to apply RFID technology to nuclear-power-plant systems, we at Hitachi have recognized the importance of realizing this role.

ID information is attached to cables, pipes, etc. from the materials stage (namely, “source tagging”), related to design information and construction records, and recorded in an IT (information technology) system. In this way, physical objects and work information in

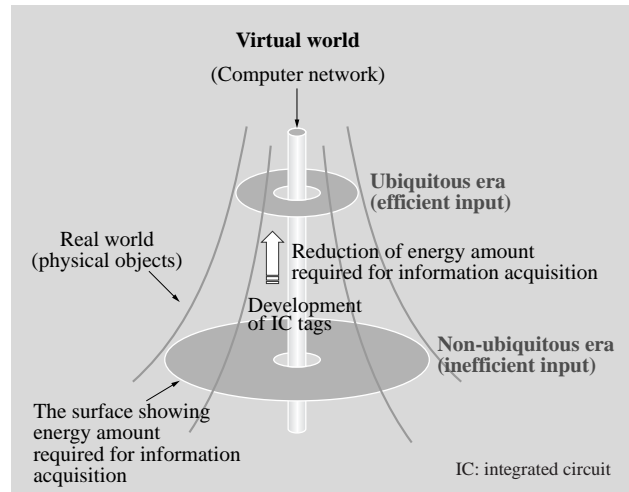

Fig. 8—RFID Technology as a Bridge Between the Real and Virtual Worlds.

RFID technology reduces the energy consumed by information processing; it can thus merge with network technology and help configure a “ubiquitous society.”

the real world can be referenced from anywhere through a network with ID information as a key. Conversely, the status of objects and work in the real world can be verified from data in the virtual world. The future ideal regarding RFID-application systems (referred to as “intelligence”) is that the real world and virtual world will be united with granularity not heretofore possible and that workers will be able to accurately determine conditions while receiving support from computer systems. Hitachi will continue to apply this ideal to systems for assuring safety, high quality, and high reliability of people, things, and work operations and, in doing so, assure the quality and reliability of nuclear power plants.

CONCLUSIONS

This report, first, described development matters concerning systems applying RFID technology to manufacturing control, construction management, and maintenance in nuclear power plants and, then, outlined the future ideal concerning RFID technology. In recent years, the expansion of RFID technology has been prominent. Given that fact, from now onwards, the Hitachi Group will continue to actively expand the application domain of RFID technology in accordance with further development of RFID versatility and performance and promote research and development of many kinds of RFID-application technologies. In this way, we are aiming for further improvement of quality, reliability, and safety of nuclear power plants.

REFERENCES

- (1) K. Araki et al., "Application of RFID Technology to Construction of High-reliability Nuclear Power Plants," *Hitachi Review* **55**, pp. 94–98 (2006).
- (2) M. Usami et al., "Ubiquitous Technology IC Tags," Ohmsha, Ltd. (Mar. 2005) in Japanese.
- (3) M. Usami et al., "An Ultrasmall RFID Chip: μ -chip," *Oyo Buturi* **73**, No. 9, pp. 1179–1183 (Sep. 2004) in Japanese.
- (4) M. Usami et al., "The μ -chip in the Ubiquitous Society," *Journal of the Information Processing Society of Japan* **45**, pp. 410–413 (Apr. 2004) in Japanese.
- (5) T. Odaka et al., "Sensor Network Converting Field Data into Users' Value," *Hitachi Hyoron* **89**, pp. 546–549 (Jul. 2007) in Japanese.

ABOUT THE AUTHORS

**Kimiharu Onda**

Joined Hitachi, Ltd. in 2005, and now works at the Nuclear Plant Department, Hitachi-GE Nuclear Energy, Ltd. He is currently engaged in the development of plant construction systems and RFID-applied construction systems.

**Keiro Muro**

Joined Hitachi, Ltd. in 1993, and now works at the Intelligent Media Systems Research Department, the Central Research Laboratory. He is currently engaged in the development of sensor-network systems for preventive maintenance. Mr. Muro is a member of the Information Processing Society of Japan.

**Eisuke Wakabayashi**

Joined Hitachi, Ltd. in 2003, and now works at the Nuclear Plant Department, Hitachi-GE Nuclear Energy, Ltd. He is currently engaged in the design of nuclear-plant piping.

**Ryosuke Shigemi**

Joined Hitachi, Ltd. in 2003, and now works at the Nuclear Equipment Manufacturing Department, Hitachi-GE Nuclear Energy, Ltd. He is currently engaged in research on electrical-field engineering. Mr. Shigemi is a member of The Institute of Electrical Engineers of Japan.

**Ryota Arai**

Joined Hitachi, Ltd. in 1991, and now works at the Nuclear Plant Control & Instrumentation Engineering Department, Hitachi-GE Nuclear Energy, Ltd. He is currently engaged in the design of nuclear plant electrical construction.

**Shinya Yuda**

Joined Hitachi, Ltd. in 1995, and now works at the Second Department of Systems Research, Hitachi Research Laboratory. He is currently engaged in the development of RFID applications for plants. Mr. Yuda is a member of The Japan Society of Mechanical Engineers, The Japan Society for Precision Engineering, and the Atomic Energy Society of Japan.