

Information Infrastructure Business

Solutions and Services

Software

Hardware

Image and Information Equipment

Network Systems

HITACHI TECHNOLOGY
2008-2009

Project to Reduce Power Consumption in Data Centers by up to 50% by 2012 Using an Integrated Approach to Energy Conservation in Both the IT Equipment and Building Services

Recently there is a strong obligation on companies to take account of environmental issues as part of CSR. IT equipment such as servers and storage appliances have become an integral part of the social infrastructure and Hitachi has started two projects to reduce the overall energy consumption of data centers where this IT equipment along with electrical transformers and air conditioning systems consume large amounts of power.



Katsuya Koda (left), General Manager, Strategy Planning & Development Office, Senior Manager, Harmonious Computing Management Center; Masaki Ito (right), Senior Engineer, Harmonious Computing Management Center, Strategic Business Development Division, Strategy Planning & Development Office, Information & Telecommunication Systems

Achieving IT Objectives with Consideration for the Environment

Green IT (information technology), which involves using IT in an environmentally conscious way, is an issue that must be confronted by IT vendors around the world. One of the core objectives underlying the use of IT is to improve the convenience of business and social activities through the use of servers, storage appliances, and network equipment developed using leading-edge technologies, and to mitigate the burden on the environment by optimizing production and distribution. However, if the increase in power consumption that results from this growing use of IT itself becomes a factor in global warming, then this is a case of the tail wagging the dog. IT vendors now need to produce IT equipment and data centers that have less of an impact on the environment and to use their wisdom and expertise to achieve these underlying objectives of IT.

New Data Center Aims for a PUE of 1.6 or Less

Accordingly, Hitachi is actively pursuing green IT as part of its CSR (corporate social responsibility) activities and is involved in "The Green Grid," an industry consortium dedicated to advancing energy efficiency in data centers, and the "Climate Savers Computing Initiative," an organization launched by the World Wildlife Fund (WWF) to facilitate more energy-efficient PCs (personal computers) and servers. Hitachi has also initiated two other major projects under its own initiative.

The first of these is to improve the energy efficiency of the company's IT products including servers and storage appliances at the operational, equipment, and component levels. This plan aims to achieve a cumulative reduction of 330,000 t of CO₂ (carbon dioxide) emissions by 2012 through the use of sophisticated energy-efficient operation and control based on Hitachi's JP1 (Job Management Partner 1) operation management software along

with cooling, power conservation and other technologies, including Hitachi's own virtualization technology.

Building on the results of this first plan, the second plan aims to reduce data center power consumption by up to 50% (compared with 2007) by 2012 by optimizing various essential data center services including air conditioning, power supplies, electrical transformers, and building management systems. For a new data center which started construction in April 2008 and is to enter service in July 2009, Hitachi aims to achieve a PUE (power usage effectiveness)* efficiency index of 1.6 or less.

Hitachi Group Has Technology and Expertise in Both IT Equipment and Building Services

Poor in resources and dependent on imports for most of its energy, Japan is recognized as a country that excels in energy saving technologies and sophisticated operation and control practices, as demonstrated by the excellent reputation that the "made in Japan" label on the country's automobiles, home appliances, and other products has in markets around the world. As a major player in this environment and a manufacturer of a wide range of different electrical equipment, the Hitachi Group is one of the few IT vendors in the world that can pursue energy efficiency from an extensive base of technology and expertise in both IT and building services equipment. Capitalizing on these advantages, Hitachi aims to continue to lead the world in efforts to improve energy efficiency as typified by green IT.

* Total data center power consumption as a proportion of IT equipment power consumption. This value is typically around 2.0 and a value of 1.6 represents a level of energy efficiency close to the limit of what is considered practical.

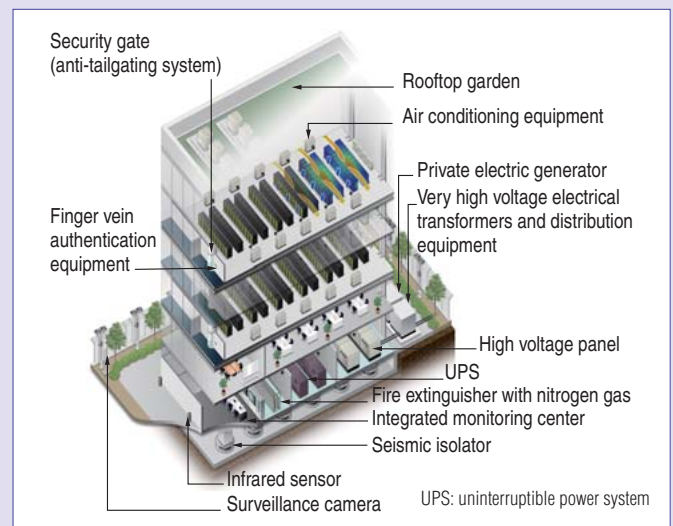

Interior of new data center

Disk Array Subsystems with Improved Virtualization Functions

Hitachi Universal Storage Platform V / Hitachi Universal Storage Platform VM

Growing data volumes and greater diversity of storage requirements require an environment that makes optimum use of storage resources. Under a new concept called Services Oriented Storage Solutions, Hitachi, Ltd. has developed two new disk array subsystems named Hitachi Universal Storage Platform V and Hitachi Universal Storage Platform VM that are the world's first enterprise arrays to provide "virtualization of volume capacity."

An Optimized Storage Environment for an Era of Explosive Growth in Information

Driven by regulatory compliance requirements and a more diverse business environment, there has been a sharp increase in unstructured data such as e-mail, image, and video items. Compared with databases and other structured data, calculating future capacity demand for such data is extremely difficult. On the other hand, the storage used in conventional business systems requires that capacity design work be carried out to predict the necessary data volume and ensure that capacity is made available. In addition, because sharing storage space among volumes is not possible, unused capacity from another volume cannot be reassigned if a particular volume becomes full. For this reason, there is a growing need to improve storage usage efficiency and reduce installation and running costs in response to these ever-increasing data volumes. Hitachi's storage virtualization technology has built up an excellent reputation for its ability to provide "virtualization of storage devices." To meet the requirements described above, Hitachi has further developed this technology to create the world's first enterprise array able to provide "virtualization of volume capacity."

Volume Capacity Virtualization Technology Eliminates the Need for Complex Capacity Design

This new technology allocates virtual volume capacity to each business system and can dynamically assign the actually used data capacity from a centrally controlled physical storage area that acts as a storage pool. Because the capacity of virtual volume is not restrained from the physical storage, a larger capacity can be pre-allocated. Available capacity in the storage pool can also be shared with other business systems.

In addition to the existing "virtualization of storage devices" function, "virtualization of volume capacity" can be used on external storage connected to Hitachi Universal Storage Platform V or Hitachi Universal Storage Platform VM. This frees the system administrator from the task of performing capacity design, provides better storage utilization, and takes maximum advantage of the benefits of storage integration. Furthermore, as the capacity of the storage pool can be increased without requiring server configuration changes or a system shutdown, capacity can be added in a timely manner to optimize and reduce installation, electricity and running costs.

Integrated Storage Solution Contributes to Customer Businesses

Both of the new models feature cutting-edge storage virtualizations including virtualization of volume capacity, virtualization of storage devices, and virtual private storage whereby subsystem resources are allocated virtually. The processor capacity, internal data transfer performance, disk access path performance, and

power-saving design features of the systems are at industry-leading levels. Also, performance design prior to installation is simplified by the processor load balancing technology that makes maximum use of available processor performance even if the load varies over time.

With Hitachi Universal Storage Platform V aimed primarily at large-scale enterprise systems and Hitachi Universal Storage Platform VM, which permits the installation of controller units as small as 10 U (about 444.5 mm) only, aimed at midrange systems, the platforms offer powerful capabilities in areas like centralized storage management and operation. By offering integrated storage solutions based around the Hitachi storage management software and Hitachi storage services, and by working on further advances in storage virtualization technology and hardware, Hitachi aims to provide customer businesses with greater added value and lower TCO (total cost of ownership).



Hideo Tabuchi (back left), Engineering Manager, Products Planning Department, Strategic Business Planning; Manabu Yamagata (back right), Engineering Manager, Disk Array Hardware Development Department; Masanobu Yamamoto (front), Engineering Manager, Disk Array Software Development Department II, Storage Systems Development, Disk Array Systems Division, Information & Telecommunication Systems



UHF Band μ -Chip Hibiki with Secure Features (Hitachi RFID μ -Chip Series)

RFID (radio-frequency identification) that uses the UHF (ultra-high frequency: 860–960 MHz) band, which has a longer communication distance and allows both reading and writing data, has been adopted in supply chain and logistics applications. Hitachi, Ltd. has released the UHF band μ -Chip, an RFID that is compatible with the ISO (International Organization for Standardization)/IEC (International Electrotechnical Commission) 18000-6 Type C international standard for the UHF band and incorporates security features to ensure data privacy and the protection of corporate data stored on RFID. The μ -Chip uses the secure RFID protocol developed by the “Secure RFID Project” (August 2006–March 2007) conducted by METI (Ministry of Economy, Trade and Industry) of Japan in order to provide corporate data protection and privacy protection, both of which are important user requirements. Use of the RFID protocol means the μ -Chip has a wide range of possible applications such as global SCM (supply chain management), traceability, and PLM (product lifecycle management) in international logistics. Hitachi intends to develop RFID and systems technol-

ogy further and to expand its range of RFID products and solutions that utilize RFID worldwide.



μ -Chip Hibiki with security features

“Finger Vein Money” for Cardless Payment Service

Hitachi has developed a biometric cardless credit payment system called “finger vein money” which allows shoppers to pay for purchases using only their fingertips.

Finger vein money relies on Hitachi’s finger vein authentication technology, which verifies a person’s identity by reading the pattern of blood vessels in his or her fingers. These blood vessel patterns are unique to each individual, much like a fingerprint or iris pattern, only they are hidden securely under the skin which makes them all the more difficult to counterfeit. Hitachi’s finger vein authentication technology has already been used to verify user

identities for ATMs (automated teller machines), door access control systems, and computer login systems in Japan and several other countries.

Hitachi ran a three-month field test (September–November, 2007) that involved 240 Hitachi employees volunteering to use finger vein money at the company cafeteria and shops in the Hitachi System Plaza Building located in Shin-Kawasaki. The trial was a success and Hitachi now plans to offer the service to credit-card companies.

As a cardless payment system that promises the ultimate in both

convenience and security, finger vein money will contribute not only to the disappearance of credit cards and all the anxieties associated with their loss and theft, but will also make it more convenient to make purchases in situations where you would not normally carry money or a card, such as at the gym, health spa, or beach.

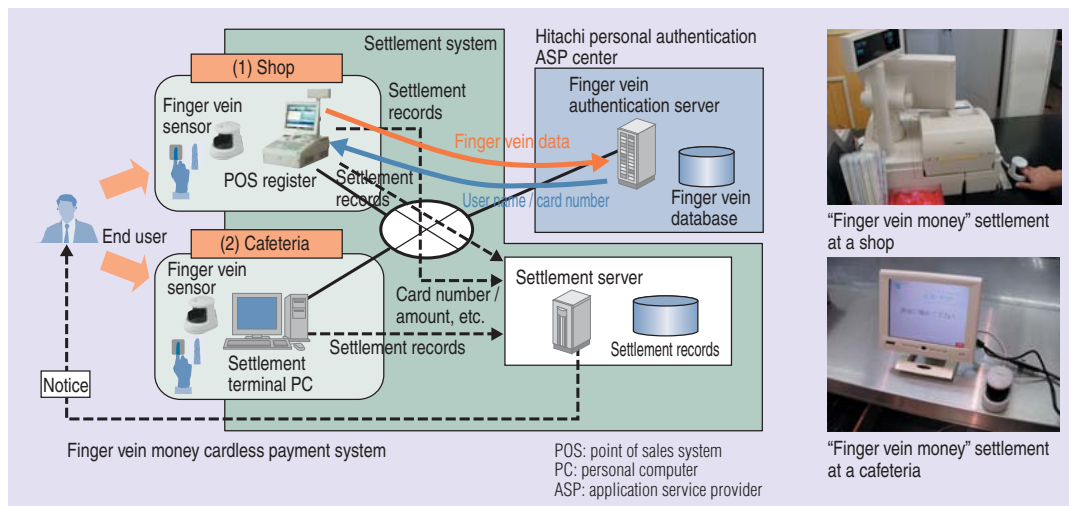

“Finger vein money” settlement at a shop



“Finger vein money” settlement at a cafeteria

Hitachi Smart Card Solutions

Smart cards have been adopted in recent years in response to high demand for secure cards that can be used globally. MULTOS* (Multi-application Operating System) is a multi-application smart card OS (operating system) with security certifications that include ITSEC (Information Technology Security Evaluation Criteria) E6 High [equivalent to EAL (Evaluation Assurance Level) 4+] and its card life cycle is strictly controlled by KMA (Key Management Authority) using KMA keys.

Hitachi has been involved in MULTOS business for more than 10 years, and Hitachi's MULTOS package provides a wide range of MULTOS related products and solutions. Products and services available through MULTOS package include IC (integrated circuit) chips and other key components, KMA keys and smart card applications (credit, cash, finger vein authentication, etc.), as well as system integration and technical support.

Hitachi has developed a new sales route for this "one stop service" in cooperation with card bureaus.

(1) Existing sales route: Hitachi delivers completed smart cards to card issuers (banks) directly.

(2) New sales route: Hitachi delivers IC chips and related applications as components to card bureaus. The card bureaus then deliver completed smart cards to card issuers. In this case, Hitachi supplies MULTOS package to card issuers via the card bureaus.

This new sales route has expanded Hitachi's share of the MULTOS card market. Hitachi currently provides MULTOS package mainly

to the Japanese and Korean financial sectors. In the future, Hitachi aims to expand MULTOS package globally and promote new business in public-sector markets where security is an important requirement, such as e-passports and national identification cards.

* See "Trademarks" on page 90.

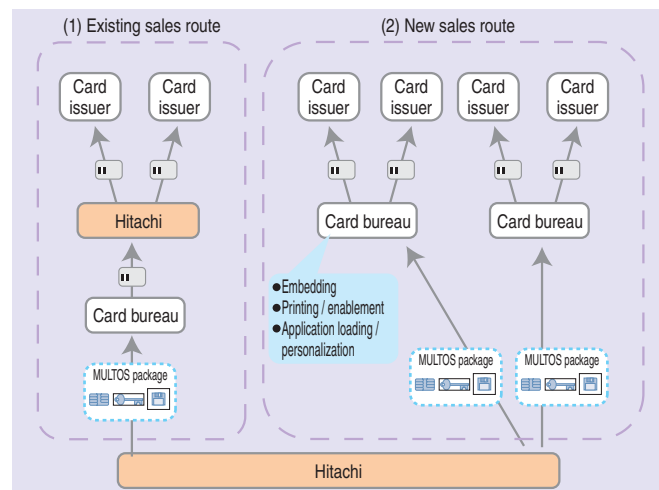

Outline of MULTOS package smart card solution

Hitachi Electronic Tally Solution Enhancement

Hitachi has added the Electronic tally for client to its electronic tally solution range of products. The Electronic tally for client is used to protect confidential data.

The tally is a security technology that works by encoding the data to be secured and breaking it up into a number of different files. This makes it impossible to recover the original data unless all of the files are available.

The tally divides files that have been placed in a user-defined folder, called the tally object folder, and saves the data on USB (universal

serial bus) flash memory and the laptop PC (personal computer). The USB flash memory is used for user authentication. The user inserts the USB flash memory into the laptop PC.

After the user logs in, a utility program such as Windows* Explorer starts automatically to allow the user to start using the Electronic tally for client.

When the Electronic tally for client is running, copying a file to the tally object folder causes it to be divided automatically.

If a user then double-clicks on the file to open it, the file is auto-

atically restored and opens in the normal manner. Similarly, the file is automatically divided again when the user closes the file.

If a user saves a file to the tally object folder when the Electronic tally for client is not running, the Electronic tally for client automatically divides the file the next time it starts.

Accordingly, by installing the Electronic tally for client, users can be sure that their files are protected at all times.

* See "Trademarks" on page 90.

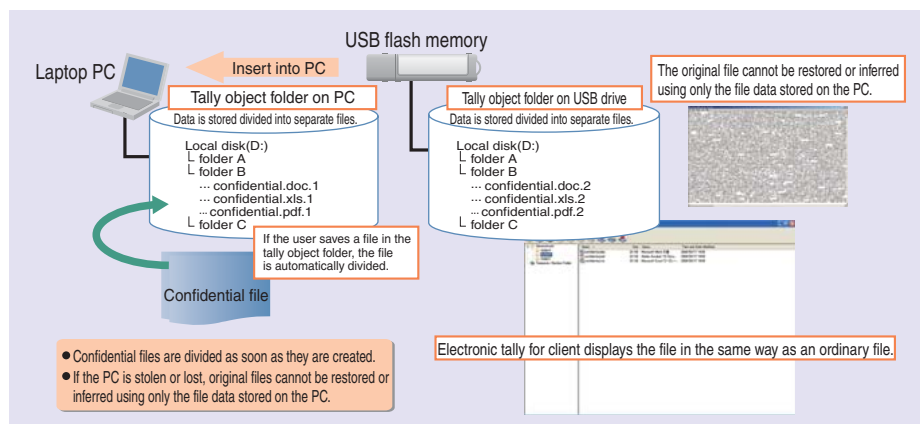

Electronic tally for client structure

TWX-21 Supporting Global B to B e-Commerce

As manufacturing industry operations such as production, sales, and design are becoming increasingly specialized at a global level, there is a growing demand for sharing of information between businesses and problem identification in order to realize the benefits of SCM (supply chain management), which include shorter lead times and minimizing of inventory levels.

The TWX-21 B to B (business to business) business media service supports the full range of business activities by providing EDI (electronic data interchange) services for web-based data exchange and information sharing among corporations in Asia, Europe, and the USA. The service is currently in use at 38,000 companies in Japan and 3,000 companies abroad in 20 countries. In particular, it is used for EC (electronic commerce) in the global procurement system at the Hitachi Group, where EC transactions with 500 business partner companies are carried out from 56 ordering sites.

Features that support global operations include the functionality required for import and export (display of shipping and arrival dates, display of invoice forms), support for specific business practices (such as taxation regimes), 24-hour service, multilingual screens and forms (Japanese, English, and Chinese), help desk ser-

vices (based in Japan and Hong Kong), reduced packet loss and shorter communication delays through dynamic control of the optimum path through the Internet, and a function to send screens in compressed form.

The prevention of processing omissions is an important consideration in terms of problem identification. TWX-21 makes the sequence of processing more transparent and has a function to trigger an alarm if information is left unprocessed.

Sharing of information among SCM participants including secondary business partners requires functions that suit the type of business activity. TWX-21 offers access control (operation control) by setting up authorities by user ID (identification). It also incorporates a function to customize screen layouts and the data being exchanged that allows these settings to be modified in realtime.

To make the service that provides these functions available with quick installation and minimum initial investment, TWX-21 is provided as an SaaS (software as a service). Hitachi intends to continue to provide this support for members entering the global market.

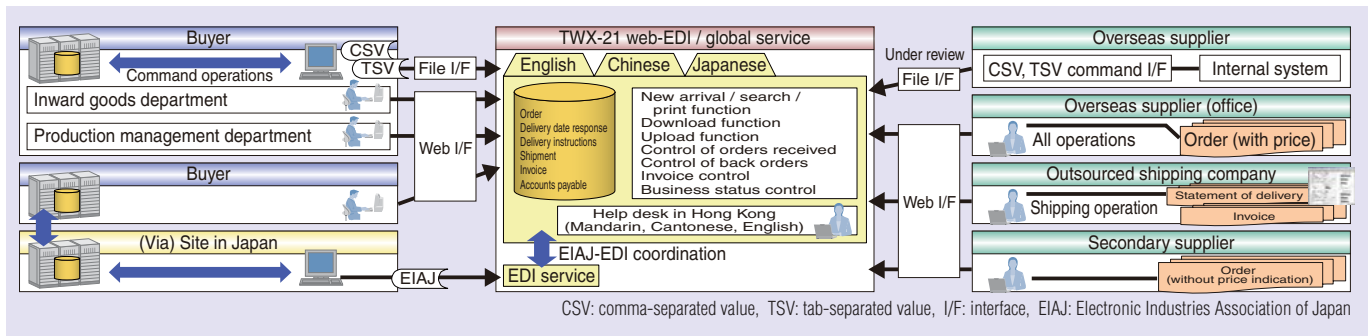

TWX-21 web-EDI global service

Integrated Systems Management Software JP1* —a Key Element in Secure Information Systems

Companies are implementing tighter internal controls to ensure protection against illegal actions, compliance with regulations, prevention of fraud, and the elimination of errors. To achieve this, JP1 provides protection from a variety of security risks, including measures for preventing information leaks and unauthorized operations.

JP1 keeps a record of file operations on client PCs (personal computers). Main information collected/searched is user name, file name, time, path, file operation (create, delete, copy, move, rename, etc.), and drive type (local disk, network drive, removable medium, etc.).

The GUI (graphical user interface) can be used to track specific files by showing the source and destination for file copy or move operations. This is useful for tracking the sequence of actual operations in the case of information leakage. It can also prevent unauthorized operations through regular monitoring.

Operation logs can be tabulated by PC or department in accordance with specified conditions. Users can check when and how many times unlicensed software has been run or authorized copies made, based on the category of operation.

* JP1 is an acronym for Job Management Partner 1.

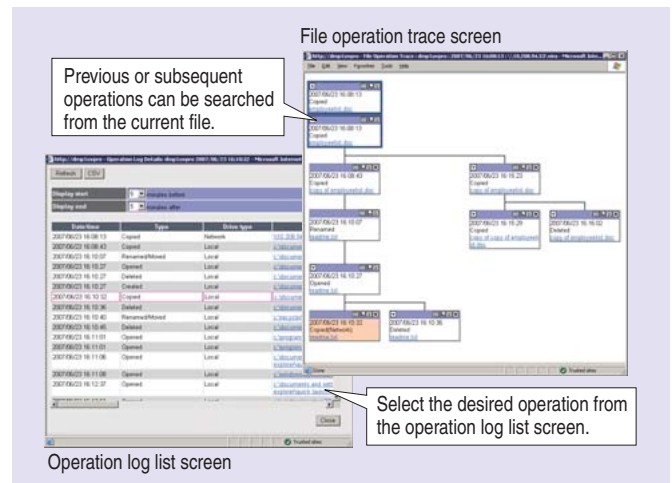

JP1 screenshot

Integrated System Construction Platform for Flexible, Highly Adaptable Systems

There is a growing need for totally optimized systems that are flexible enough to respond to the ever-changing business environment. Hitachi, Ltd. provides an integrated system construction platform that can be used to develop and execute such systems.

The latest version provides an integrated set of products that adds a batch operation capability to the existing online and workflow operation functions. The system is aimed at implementing totally optimized systems with an SOA (service-oriented architecture)

based on the concepts of rapid development, pluggable configuration, and collaborative operation. The new batch operation capability brings mainframe batch support functions to an open environment.

To ensure that users can get the best out of the platform, Hitachi has produced a reference architecture and application guide in Japan which provides typical system configuration patterns and guidance on the use of each pattern. This ensures efficiency and quality in all steps, from the system proposal and design stages to implementation and operation.

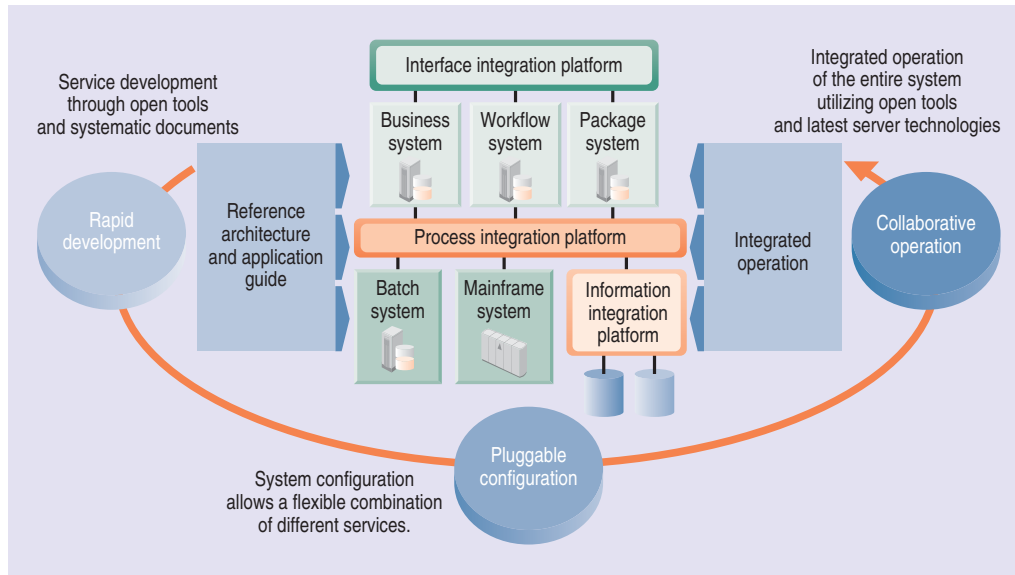

Concept diagram for the integrated system construction platform

Entier: An Embedded Database Suitable for Various Applications — Multitasking Support and Easier Customization via User Coding

The Entier embedded database is an RDBMS (relational database management system) for embedded equipment that incorporates advanced search features. These include spatial searching to find buildings on maps, full-text searching to find characters in a text, and filtered searching that narrows down the search based on the first character in the text. The multitasking capability of the Entier embedded database also makes it easier to use.

[Main features]

(1) Multitasking capability

In complex applications, each operation is assigned to a separate task. There are tasks for a wide range of different operations, including tasks that perform task management, receive input, refresh the display, and execute the application logic. Because each of these tasks can access Entier independently, application development is simplified because there is no need for complex inter-task coordination. This flexibility makes Entier suitable for any application.

(2) Easier customization

Customization functions that include the use of UOC

(user own coding) to calculate the distance in a spatial search or user-defined orthographic variations in a full-text search mean the system can be adapted flexibly to meet functional requirements during application development.

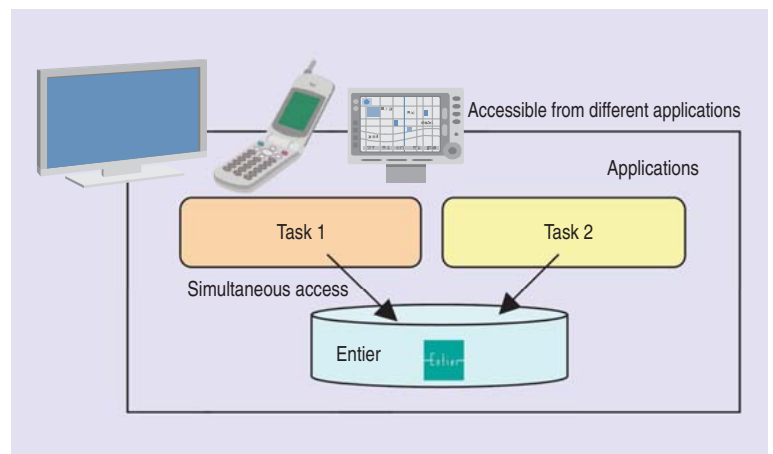

Simultaneous access from multiple application tasks



Hitachi Server Platform Overview

Hitachi offers a variety of computer products ranging from client systems and PC (personal computer) servers to mainframes and supercomputers, using the experience gained over more than 40 years in computer manufacturing.

Mainframe products running Hitachi's VOS (virtual-storage operating system) provide the high reliability and high availability required for mission-critical applications.

Hitachi super technical servers deliver a high level of computing performance for HPC (high performance computing) applications such as weather forecasting, crash test analysis, and environmental simulation.

Enterprise server customers who use the AIX* OS (operating system) can run their mission-critical applications on Enterprise UNIX* server series machines.

The multi OS server product line based on Intel Itanium* processors offers a choice of HP-UX*, Windows or Linux*, and scales from two cores to large 128-core SMP (symmetric multi processor) servers. The mainstream PC server series uses Xeon or Pentium* processors and runs Windows or Linux.

BladeSymphony is a highly scalable, performance-oriented blade server platform that supports multiple operating systems on Intel Xeon and Itanium processors to address the needs of the modern data center.

The secure client solution consists of thin clients connected to PC hardware in the security of a

data center.

Overall, whatever the user requires, Hitachi has the appropriate server products.

* See "Trademarks" on page 90.



Hitachi server platforms for various IT (information technology) infrastructures

Hitachi's BladeSymphony Integrated Service Platform

Designed for maximum performance and scalability, BladeSymphony is a highly integrated next-generation IT (information technology) platform, managing not only servers but also storage and network resources.

The BladeSymphony Management Suite allows central management of system configurations that include multiple chassis and racks of blade servers. It also allows the various system resources to be managed through a unified dashboard. This provides customers with reduced

complexity through integrated management, lower total cost of ownership, and an improved return on investment.

Hitachi offers two BladeSymphony models: (1) the 10-U (about 444.5-mm) high-end blade server (with Intel Xeon or Intel Itanium processors), providing enterprise-class capabilities for mission-critical applications, and (2) the 6-U (about 266.7-mm) high-density blade server (with Intel Xeon processors) for remote office or branch office workloads. Customers can select the appropriate model according to their specific business needs. All server blades can run Microsoft* Windows Server* or Red Hat* Enterprise Linux*. By providing green IT in BladeSymphony, customers can consolidate servers by using Hitachi's unique server virtualization feature of the high-end blade server and select a low power consumption server blade of the high-density blade server.

* See "Trademarks" on page 90.



BladeSymphony integrated service platform

Security PC

The Security PC (personal computer) is a thin-client PC with no hard disk or printer function. This means that the PC cannot save data on a local HDD (hard disk drive) or print documents. The security PC uses an authentication device and can free mobile executives from the fear of critical information loss if the PC is lost or stolen.

Both user files and application software are stored on blade PCs or other servers at the enterprise's internal information system center. This allows users to access and use data and applications via the Internet (or intranet) safely wherever they are.

End users can also store presentation data in their authentication device and make presentations using the PowerPoint* viewer of security PC (optional service) when they have to work offline.

The ultra light mobile client weighs as little as 1 kg and provides up to five hours of operation with the standard battery.

The compact desktop model is more than 70% smaller than the previous model. Both models are able to use finger vein authentication (option) for enhanced security. This feature uses biometrics

technology developed by Hitachi.

* See "Trademarks" on page 90.

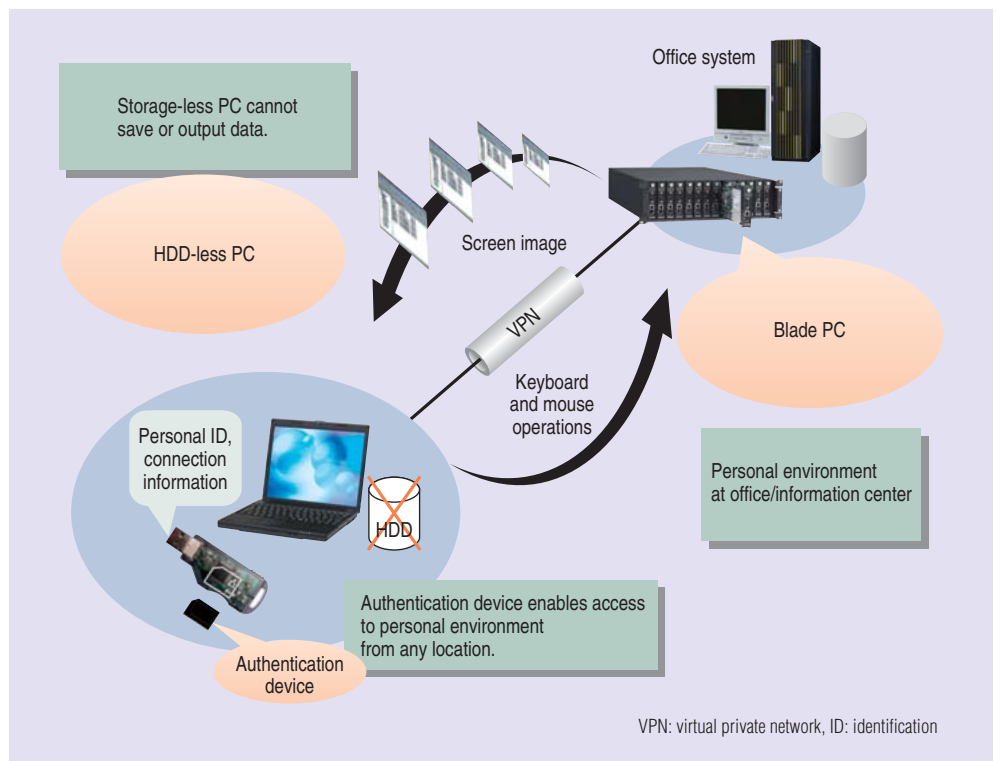

Overview of security PC

Hitachi Universal Storage Platform V and Hitachi Universal Storage Platform VM Disk Array Subsystems

Hitachi Universal Storage Platform V released in May 2007 and Hitachi Universal Storage Platform VM released in September

2007 are core products in Hitachi's range of disk array subsystems and are part of the company's Services Oriented Storage Solutions,



Hitachi Universal Storage Platform V (left) and Hitachi Universal Storage Platform VM (right)

an integrated storage solution concept that focuses on customer operations and makes optimum use of storage resources without requiring the user to concern themselves with complex system configuration or operational issues.

With leading-edge virtualization functionality provided by the Hitachi Dynamic Provisioning volume capacity virtualization function and Hitachi Universal Volume Manager storage device virtualization function, these products provide an even better return on storage investment by enabling efficient use of storage resources across the data center, with simple and centralized storage management and lower running costs.



Hitachi Essential NAS Platform, an NAS Product with Enhanced Connectivity, Scalability, and Data Protection



Hitachi Essential NAS Platform

Hitachi has launched the Hitachi Essential NAS Platform, an NAS (network attached storage) product with enhanced connectivity, scalability, and data protection.

[Main features]

(1) Customers can select and connect to different Hitachi disk array subsystems according to their needs.

(2) The system can be adapted to changes in the customer's requirements, such as an increase in the number of clients, by adding optional upgrades to the NAS device or by adding NAS devices themselves.

(3) Enhanced data protection capabilities through faster tape backup and support for remote backup over an IP (Internet protocol) network.

These features make Hitachi file storage solutions highly flexible and scalable to meet customer requirements.

(Released in November 2007)

Hitachi Simple Modular Storage 100 Low-end Disk Array

Hitachi has launched "Hitachi Simple Modular Storage 100," low-end disk array that can be handled by users with simple operation in overall storage management including introduction, operation and maintenance of disk arrays.

This product will significantly reduce the burden of system administrators in operation and maintenance in addition to easy introduction to finish a range of procedures from unpacking to recognition by the server in less than one hour through the use of the dedi-

cated "easy setup wizard." In order to meet the growing need of higher reliability in medium-sized companies, adoption of RAID (redundant array of independent disks) 6 and duplication/redundancy of major components are implemented.

"Hitachi Simple Modular Storage 100" is expected to be utilized as optimal storage for middle-size companies' core systems and small-scale department systems.

(Released in October 2007)



Hitachi Simple Modular Storage 100

Hitachi Content Archive Platform

Delivering an Active Archiving Solution for Digital Fixed Content

As companies strive for better management of information growth, regulatory compliance, litigation discovery, and corporate governance, they are facing unprecedented demand, not only for secure long-term preservation and retention of digital fixed content, but also for ready access to that content whenever it is needed.

The Hitachi Content Archive Platform establishes an “active archive” environment—a single online solution that enables protection, search, and retrieval across numerous content types. Based on a unique SAIN [SAN (storage area network)-attached array of independent nodes] architecture, the Hitachi Content Archive Platform fully leverages Hitachi storage and archive software capabilities for high availability, performance, and scalability from 4 Tbyte up to multiple petabytes.

Traditional storage systems have focused on structured data—information contained within the well-defined constructs of a database. However, the rapid growth of digital content, called unstructured or semi-structured data has resulted in an information explosion. Semi-structured data includes e-mail messages and unstructured documents containing e-mail metadata, such as who sent the message under what subject with what attachments to whom and when. Unstructured data includes documents, spreadsheets, graphics, still and moving images, and other data formats stored in file systems.

The Hitachi Content Archive Platform is based on well established records management and archival science practices and takes a policy-based, object-oriented approach to support the business requirements of retention, access, and retrieval of numerous types of content across multiple applications, delivering integrated indexing and search software services to the archived fixed-content data.

Companies now recognize that storing archived fixed-content information in online, disk-based “active archive” storage systems offers an alternative to traditional offline (passive) archival storage using tape, microfiche, optical disk, or paper as the archival media. An online, disk-based “active archive” can not only improve a company’s ability to respond to business requirements such as legal discovery, it can also improve online relational database performance by taking the infrequently needed data out of the relational database. An “active archive” can also reduce the disruptive [business and IT (information technology)] impact of all types of auditing (including Sarbanes-Oxley) and discovery.

The Hitachi Content Archive Platform scales to support an increasing number of applications, capacity for new content, and the high availability needed to ensure it is accessible when needed. The platform scales horizontally to archive content across a variety of applications and vertically to address the continuing growth of content that must be retained. It is available in the following configurations:

(1) Hitachi Content Archive Platform 300

RAIN (redundant array of independent nodes) configuration provides dual copies of all archived content and high availability through node failover.

(2) Hitachi Content Archive Platform 500

SAIN architecture provides increased availability through node and path failover as well as optional additional copies of archived content.

(3) Hitachi Content Archive Platform is also available in a fully-customizable configuration, built upon the Hitachi Content Archive Platform 500, to meet the specific needs of any organization.

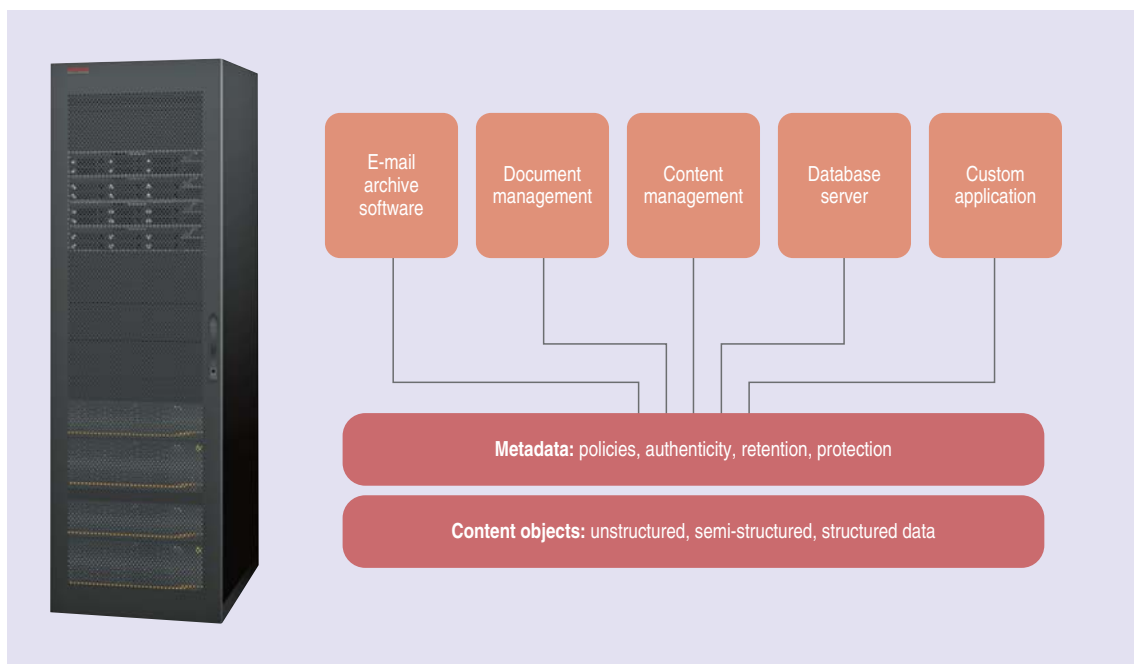

Hitachi Content Archive Platform (left) and solutions (right)



Camera and Recorder for Video Surveillance

Hitachi has developed the VK-S454N series as cameras and DS-G series as digital recorders for surveillance.

(1) VK-S454N series, zoom camera module

The VK-S454N series is a zoom chassis camera (23 × optical zoom, 12 × digital zoom) to achieve high-quality images in various environments, such as where there is a wide gap between illuminance levels or where limited illuminance is available, with the newly developed DSP (digital signal processor) realizing high resolution (540 TV-lines), high sensitivity (minimum sensitivity of 1.0 lx) and low noise (frame noise reduction function). With 8-bit digital output in addition to conventional analog output, it has ability to deliver acquired images to camera systems of customers without deterioration. This series is capable of contributing to highly efficient high-quality systems in the video surveillance field, where further sophistication including introduction of the IP (Internet protocol) is under way.

(2) DS-G series, digital recorder

The DS-G series has high-quality progressive recording (704 × 480 pixels), large-capac-

ity recording (1-Tbyte built-in capacity and 4-Tbyte external) and remote surveillance function as well as the face detection and face search function that instantly detects human faces only by using the main body of the recorder and exclusively displays face images among enormous quantity of recorded data. This function may save significant time for search such as identification of people. The DS-G series is also designed to ensure the protection of personal information, providing flexibly configurable authority for operation of the main body by user and password-based data protection as safety measures.



Camera (a) and recorder (b) for video surveillance

CP-A100 Projector with an Ultra-short Throw Distance

The world's first ultra short throw distance projector CP-A100 which uses both free shaped mirror and free shaped lens was released in November 2007. The projector can display an 80-inch (about 203.2 cm) screen from a distance of only 63 cm, making it suitable not only for classrooms and conference rooms but also in

situations such as shop windows and amusement plazas where space is limited. The projector solves the problem of the presenter throwing a shadow on the screen. The projector can be operated from a desk or from an upright position using an optional kit. It can also be controlled and monitored via a network.



CP-A100 ultra-short throw distance projector and example of use

AMN6200 Ultra-compact DWDM System

There is a demand for compact transmission equipment with large capacity that can reduce operational costs for backbone networks. To meet this demand, a DWDM (dense wavelength division multiplexing) function has been added to the AMN6200 CWDM (coarse wavelength division multiplexing) device. Also, bidirectional transmission over single-core optical fiber reduces the cost of fiber used.

[Main features]

- (1) Multiplexes up to 32 wavelengths in a single-core optical fiber with bidirectional transmission.
- (2) The 16-channel DWDM system has a width of 19 inches (about



AMN6200 ultra-compact DWDM system

482.6 mm) and a height of 6 U (about 266.7 mm). This is only 40% of the size of conventional products.

(3) An optical amplifier allows for long-distance transmission with a maximum loss of 35 dB (100 km or more).

(4) The numerous client interfaces supported by the AMN6200 make a wide range of client configurations possible. With the AMN6200, the number of accommodated channels can also be increased because an interface employing electrical multiplexing technology can be used.

Available interfaces include the following:

- (a) Ethernet* interface: Ethernet, FE (fast Ethernet), GbE (gigabit Ethernet), 10 GbE
 - (b) SDH (synchronous digital hierarchy)/SONET (synchronous optical network) interface: STM (synchronous transfer mode)-1/OC (optical carrier)-3, STM-4/OC-12, STM-16/OC-48, STM-64/OC-192
 - (c) Multiplexing interface: 2 × GbE, 4 × STM-4/OC-12, Triple MUX (multiplexer) (1.544 Mbit/s, Ethernet/FE, STM-1/OC-3)
- (5) The AMN6200 supports a 1+1 protection function based on an optical switch. When a fault occurs, the working system is automatically switched to the protection system within 50 ms. (Hitachi Communication Technologies, Ltd.)

* See "Trademarks" on page 90.

MSA-compliant 40-Gbit/s Optical Transmission Module for Short- and Long-distance Communications

Opnext Japan, Inc. has developed a 40-Gbit/s optical transmission module to provide even greater capacity in high-speed core router networks and optical backbone networks.

The dimensions and electrical interface of the module comply with the MSA (Multi-source Agreement) and the product range consists of two different versions: a short-distance version for transmission distances of 2 km and a long-distance version with excellent high-density optical wavelength division multiplexing performance.

A new monolithically-integrated module that combines a low-voltage optical semiconductor modulator and distributed feedback laser has been developed for the transmission unit in the short-distance version. The long-distance version employs a modulation scheme with excellent performance at converting the optical modulation spectrum to narrow-band to cope with the full C-band wavelength variability at 50-GHz channel spacings. The use of external optical amplification and dispersion compensation tech-

nologies makes the system suitable for use in metro networks that connect metropolitan areas.

(Opnext Japan, Inc.)

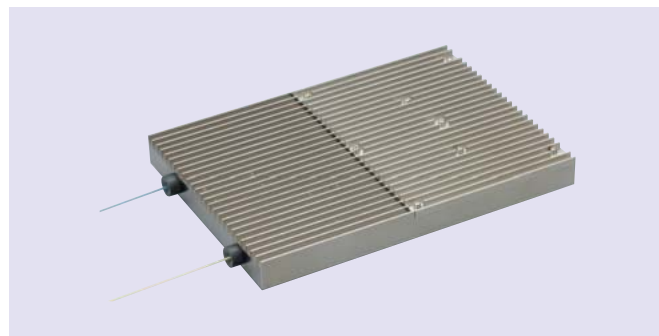

MSA-compliant 40-Gbit/s optical transmission module