

Technology for Next-generation Reduced-size High-performance Inverter

Naoki Kurihara
Shuichi Tachihara
Kenhachiro Minamide
Satoshi Yamaguchi

OVERVIEW: As part of our social infrastructure, the VVVF inverters used in rolling stock need to achieve a high degree of safety and reliability along with economical performance in the form of energy efficiency and low maintenance. With the growth of environmental awareness in recent years, environmental performance has also become a key factor. In response to these demands, Hitachi has developed a new generation of reduced-size high-performance inverters. The key concepts behind this development are compatibility with next-generation technologies and improved environmental performance. This development also includes the use of high-speed serial communications, next-generation in-vehicle communication systems, a new vector control technique which can drive high-efficiency motors, and reduction in size and weight by applying a snubberless design. An analysis-driven design methodology using analysis tools was adopted for important development criteria.

INTRODUCTION

IT is about 30 years since electric trains using VVVF (variable voltage variable frequency) inverter control first appeared in Japan. Since then, VVVF inverters for rolling stock (referred to below as “inverters”) have undergone a steady stream of improvements. The driving forces behind this development have been the high degree of safety and reliability demanded for social infrastructure and the pursuit of better economics through energy efficiency and low maintenance. On top of this, the growing concern about global environmental protection in recent years has added an extra impetus to the improvement of environmental performance.

Against this background, Hitachi has developed an inverter that suits modern requirements.

This article describes the next-generation reduced-size high-performance inverter developed by Hitachi (see Fig. 1).

DEVELOPMENT CONCEPTS

Inverters for rolling stock require a high level of environmental performance and reliability together with good economics. The next-generation reduced-size high-performance inverter was developed based on the following concepts with the aim of achieving these performance improvements (see Table 1).

Reducing Burden on Environment

In order to reduce the burden on the environment, the development focused on reducing the size and weight of the inverter, achieving a high level of efficiency, and eliminating toxic materials.

Measures to reduce the size and weight included new HiGT (high conductivity insulated gate bipolar transistor) modules, an active gate drive control technique that both reduces losses and minimizes noise, and a reduction in the size and number of components. The adoption of a new vector control technique and high-performance MPU (microprocessing unit) improved the response time for torque commands, and a high level of efficiency was achieved through support for high-efficiency motor control, improvements in the



Fig. 1—Next-generation Reduced-size High-performance Inverter. This VVVF (variable voltage variable frequency) inverter for rolling stock uses new technology to achieve reduced size and light weight.

TABLE 1. Development Concept and Technologies Used
The concepts behind the development were to reduce the burden on the environment, improve reliability, and reduce life cycle costs.

Development concept	Characteristic	Technologies used
Reduce burden on environment	Reduced size and light weight	Main circuit design with no snubber circuit
		New type of IGBT
	High efficiency and fast response	Active gate drive control
		Cascade-type vector control
Elimination of toxic materials	Encourage use of lead-free parts	
Improve reliability	Lower component count	High-performance MPU
	Analysis-driven design	Automatic program generation tools
		Electromagnetic field analysis software produced by Hitachi
Reduce life cycle costs	Reduction in maintenance cost	Elimination of cooling fan
		Elimination of batteries
	Longer life	Electronic components with low power consumption
		Replace electrolytic capacitors

IGBT: insulated gate bipolar transistor
 MPU: microprocessing unit

grip ratio, and improvements in regenerative braking under light load conditions (the condition that there are few other trains to consume the regenerative power).

Regarding the elimination of toxic materials, progress was made towards making the equipment lead-free by using lead-free solder which is used to mount electronic components.

Reliability Improvement

In response to the need to improve reliability, an emphasis was placed on reducing the number of components and on using an analysis-driven design methodology.

To improve reliability by using fewer components, high-performance MPUs were adopted and the total number of MPUs reduced.

For the use of an analysis-driven design methodology for the main circuits, the accuracy of simulation was improved through the use of coupled simulation techniques to improve quality from the design stage.

Hitachi's own integrated development environment for embedded software was used for software development. Software design support tools able to generate simulations and source code from the processing specifications were used to ensure that

rigorous quality was built-in from the earliest design stages and to eliminate human error by using automatic source code generation.

Reduction in Life Cycle Cost

The emphasis for reducing life cycle costs was placed on extending product life and reducing maintenance requirements.

To extend the product life, components with short life spans were replaced and heat generation minimized by the use of electronic components with low power consumption. Measures adopted to reduce maintenance requirements included eliminating components such as cooling fans and batteries that require periodic replacement or replacing them with alternatives that have a longer service life.

POWER UNIT

The power unit that controls high voltages and heavy currents uses a new type of IGBT (insulated gate bipolar transistor) together with an active gate drive control technique to achieve both low losses and low noise, while an analysis-driven design methodology was used to achieve high quality from the earliest design stages.

Heavy-current HiGT Module

The IGBTs are the key device in the power unit and the inverter is fitted with new HiGT modules⁽¹⁾ with a planar HiGT structure that reduce conduction losses, an LiPT (low injection punch through) structure for lower switching losses, and soft switching characteristics to reduce noise. The gate driver that controls the HiGT module incorporates an active gate drive control technique that monitors the operation in real time to achieve optimum switching control.

This combination of HiGTs with low on losses and an active gate drive control technique achieved both low losses and low noise. Further, the analysis-driven design methodology described below succeeded in producing a snubberless design by reducing the inductance and optimizing the current distribution of the conductor bars to minimize the surge voltage that occurs when IGBTs turn off.

The lower IGBT losses and improved cooling unit performance meant the size of the cooling unit could be reduced and it could be made lighter, and this together with the snubberless design resulted in a significant increase in the output to weight ratio of the power unit.

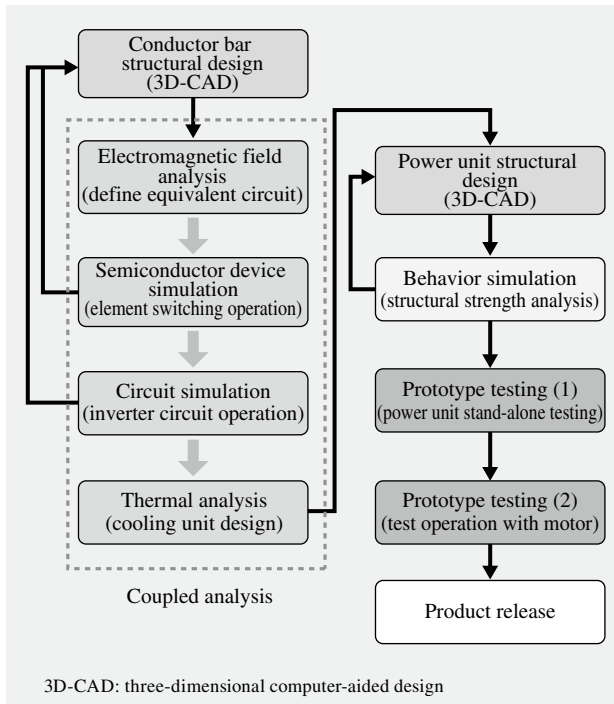

Fig. 2—Design Flow Using Coupled Simulation Analysis. The sequence of tasks leading up to thermal analysis based on models produced using 3D-CAD.

Analysis-driven Design

A coupled simulation analysis technique was used to design the power unit, the aim being to improve analysis accuracy and shorten the development time by linking together the steps from design of the conductor bar structure through to analysis of circuit operation and thermal analysis of the cooling unit.

Fig. 2 shows a flow chart of the coupled simulation analysis.

Hitachi's own electromagnetic field analysis software was used to obtain parameters such as the inductance and current distribution from models of the conductor bar and other components created using 3D-CAD (three-dimensional computer-aided design) and to define the equivalent circuit. Next, this equivalent circuit was used to conduct simulations of the semiconductor devices and circuit. The losses obtained from the circuit simulation were then used as input to the thermal analysis simulation for the design of the cooling unit.

This shortened the development time and achieved a further improvement in design quality through better analysis accuracy.

CONTROL LOGIC

For the logic circuits used to control the power unit, greater use was made of lead-free components

in order to reduce the burden on the environment, a slimmed-down circuit configuration was adopted to improve reliability, and life cycle costs were reduced by lengthening product life.

High-performance MPU

The conventional design based on using separate MPUs for each function was revised and a high-performance MPU adopted to achieve a single-MPU configuration. Using a single MPU also helped improve software reliability further by eliminating the need for inter-MPU communications.

Longer Life Achieved by Eliminating Cooling Fan

Component selection was revised and modifications made to minimize temperature increase with the aim of extending the life of the control logic. Longer life was achieved through a design that does not require a cooling fan, this being made possible by replacing the batteries and electrolytic capacitors, both of which require maintenance, with electric double-layer capacitors and multi-layer ceramic capacitors, and by selecting electronic components with low power consumption to reduce any temperature increase on the circuit board.

Compatibility with Next-generation In-vehicle Communication System

High-speed serial communications were chosen for communications, this being the expected standard

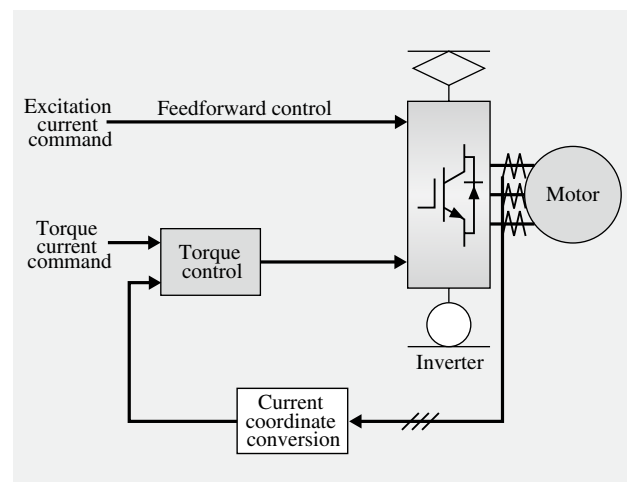

Fig. 3—Vector Control for Rolling Stock.

Feedforward control of excitation current can minimize torque variation by automatically compensating for changes in motor constants so that the motor drive can range from multi-pulse to single-pulse mode without switching between control systems.

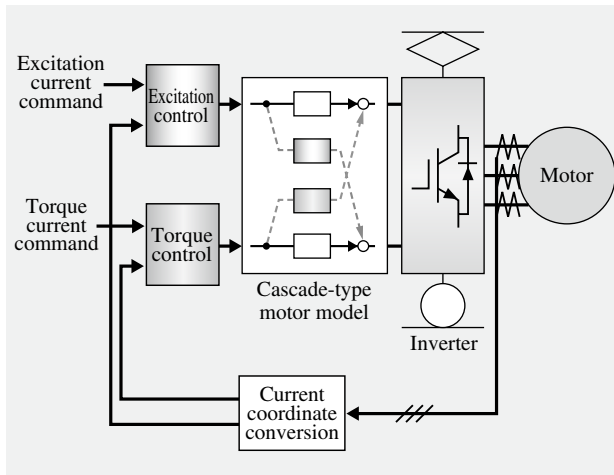

Fig. 4—Vector Control for Driving High-efficiency Motors. Use of cascade-type vector control with a model of the motor in the output stage of current control allows non-interactive control to respond to the actual situation in the motor and achieves stable drive control even of high-efficiency motors.

for the next generation of in-vehicle communication systems. The use of high-speed serial communications significantly improved the speed of operations such as reading monitoring data or writing software. To retain compatibility with legacy equipment, the design also allowed for the flexible use of existing communication standards.

CONTROL SOFTWARE TECHNOLOGIES

Vector Control for Driving High-efficiency Motor

The commonly used configuration in modern rolling stock is to use a single PWM (pulse width modulation) inverter to drive a group of induction motors. The past practice of using V/f constant control for induction motors has also largely been supplanted by vector control that provides a faster response and greater accuracy of torque control.

Hitachi developed a vector control technique for use in rolling stock⁽²⁾ and has used this in all its railway inverters since the mid-1990s (see Fig. 3). The technique uses feedforward control of the excitation current to achieve the following characteristics and has contributed to better ride quality and other improvements in rolling stock performance.

- (1) Minimize torque variation by automatically compensating for changes in motor constants.
- (2) Motor drive can range from multi-pulse to single-pulse mode without switching between control systems.

To improve further the efficiency of induction motors, growing use is being made of high-efficiency motors with lower power consumption which is

achieved by reducing the amount of motor slip to reduce drive losses. As high-efficiency motors generate less heat, they can use fully-enclosed designs to reduce motor noise and minimize maintenance requirements.

However, to reduce these losses, high-efficiency motors are designed with lower resistance in the rotating and fixed coils which makes them particularly susceptible to interference by magnetic flux generated inside the motor. This means the control system can easily become unstable. In response, cascade-type vector control⁽³⁾ was first introduced for induction motor drive control in rolling stock because it is a control technique suitable for driving high-efficiency motors with these characteristics (see Fig. 4).

Cascade-type vector control implements current control for both the excitation current and torque current and controls non-interactively by using a model of the motor to model the influence of the magnetic flux inside the motor in the output stage of current control.

Although the control technique shown in Fig. 3 also performs non-interactive control based on the current commands, use of non-interactive control techniques such as cascade-type vector control, which is based on the output of current control, allows this non-interactive control to respond to the actual motor drive situation.

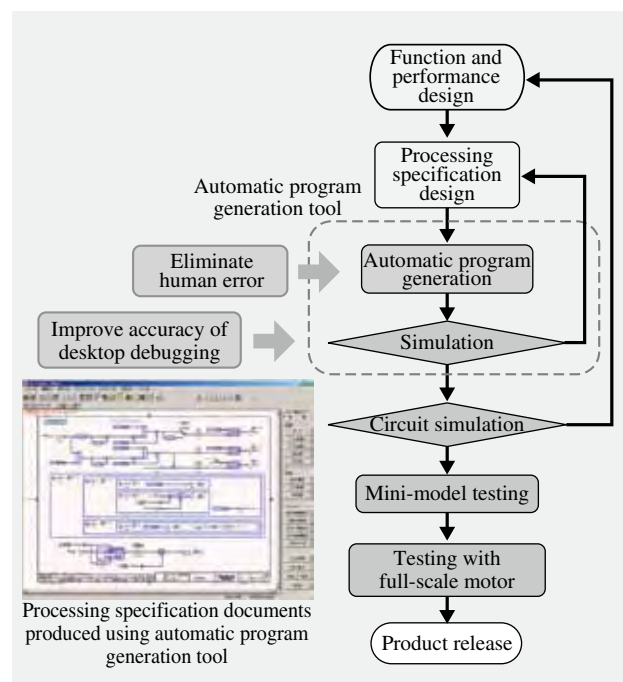

Fig. 5—Design Methodology Using Automatic Program Generation Tool.

Reliability and productivity are improved by functions to generate programs automatically from processing specification documents and simulation functions.

This helps improve the energy efficiency of rolling stock by delivering stable control of high-efficiency motors as well as of existing induction motors.

By providing current control of both excitation and torque current, the responsiveness and accuracy of torque control is further enhanced compared to the control technique shown in Fig. 3. This would also lead to improvements in grip reacquisition control under slip conditions and regenerative braking under light load conditions.

Automatic Program Generation Tool

To improve the reliability of the inverter control software used in rolling stock, Hitachi has been making use of tools that can generate program source code automatically from block diagrams (see Fig. 5). This allows programs to be generated automatically from the processing specifications, improves software readability, and reduces human error during program development. Similarly, the use of simulation functions able to operate at the level of processing specifications leads to better desktop debugging accuracy, less rework, and higher productivity.

CONCLUSIONS

This article has described the next-generation reduced-size high-performance inverter developed by Hitachi.

Inverters are not excluded from demands for better environmental performance. Hitachi intends to continue developing inverters in pursuit of greater energy savings and higher efficiency.

REFERENCES

- (1) K. Saito et al., "Low Loss, High Voltage, and Large Current HiGT Module" Hitachi Hyoron **90**, pp. 1,018-1,021 (Dec. 2008) in Japanese.
- (2) Yasuda et al., "Vector Control of Traction Inverter for Rolling Stock with Single Control System for All PWM Modes," 1998 Industry Applications Conference of The Institute of Electrical Engineers of Japan, p. 74 (1998) in Japanese.
- (3) Tobari et al., "Investigation into a New Vector Control Techniques for High-speed Permanent Magnet Synchronous Motors," 2003 Industry Applications Conference of The Institute of Electrical Engineers of Japan, pp. 1-130 (2003) in Japanese.

ABOUT THE AUTHORS



Naoki Kurihara

Joined Hitachi, Ltd. in 2007, and now works at the Rolling Stock Electrical System Design Department, Mito Transportation System Product Division, Transportation Systems Division, Industrial & Social Infrastructure Systems Company. He is currently engaged in the development of traction inverters for rolling stock.



Shuichi Tachihara

Joined Hitachi, Ltd. in 2003, and now works at the Transportation Systems Development Center, Mito Transportation System Product Division, Transportation Systems Division, Industrial & Social Infrastructure Systems Company. He is currently engaged in the development of traction inverters for rolling stock. Mr. Tachihara is a member of The Institute of Electrical Engineers of Japan (IEEJ).



Kenhachiro Minamide

Joined Hitachi, Ltd. in 2006, and now works at the Rolling Stock Electrical Systems Design Department, Mito Transportation System Product Division, Transportation Systems Division, Industrial & Social Infrastructure Systems Company. He is currently engaged in the design of traction inverters for rolling stock.



Satoshi Yamaguchi

Joined Hitachi, Ltd. in 2006, and now works at the Rolling Stock Electrical Systems Design Department, Mito Transportation System Product Division, Transportation Systems Division, Industrial & Social Infrastructure Systems Company. He is currently engaged in the design of traction inverters for rolling stock.