

# Application of Power Electronics Technology to Energy Efficiency and CO<sub>2</sub> Reduction

Masashi Toyota  
 Zhi Long Liang  
 Yoshitoshi Akita  
 Hiroaki Miyata  
 Shuji Kato  
 Toshiki Kurosu

*OVERVIEW: The effective use of electrical energy is a key technique for achieving energy efficiency, and power electronics technologies that can convert electric power into the optimum characteristics for each applications are essential part of this approach. Power electronics systems have attracted attention as key components for building a sustainable society by reducing CO<sub>2</sub> emissions and include the use of inverters as adjustable-speed drives for motors and PCSs that provide stable connections to the power grid for unstable DC or AC electric power generated from solar energy, wind energy, etc. Hitachi provides systems, products, and services that contribute to reducing CO<sub>2</sub> emissions in power generation, industry, and other sectors in social infrastructure by combining power electronics with system control technologies and technologies for power devices which are the key components in these systems.*

## INTRODUCTION

POWER electronics is a technology for using power devices to convert efficiently electric power into the optimum characteristics. As a key component for improving the energy efficiency and performance of various equipment, power electronics contributes to the

realization of both a prosperous and comfortable way of life and a sustainable society by reducing CO<sub>2</sub> (carbon dioxide) emissions in areas as diverse as electric power, industry, transportation, and home appliance.

Hitachi supplies safe, reliable, and pleasant systems by combining power electronics and system control

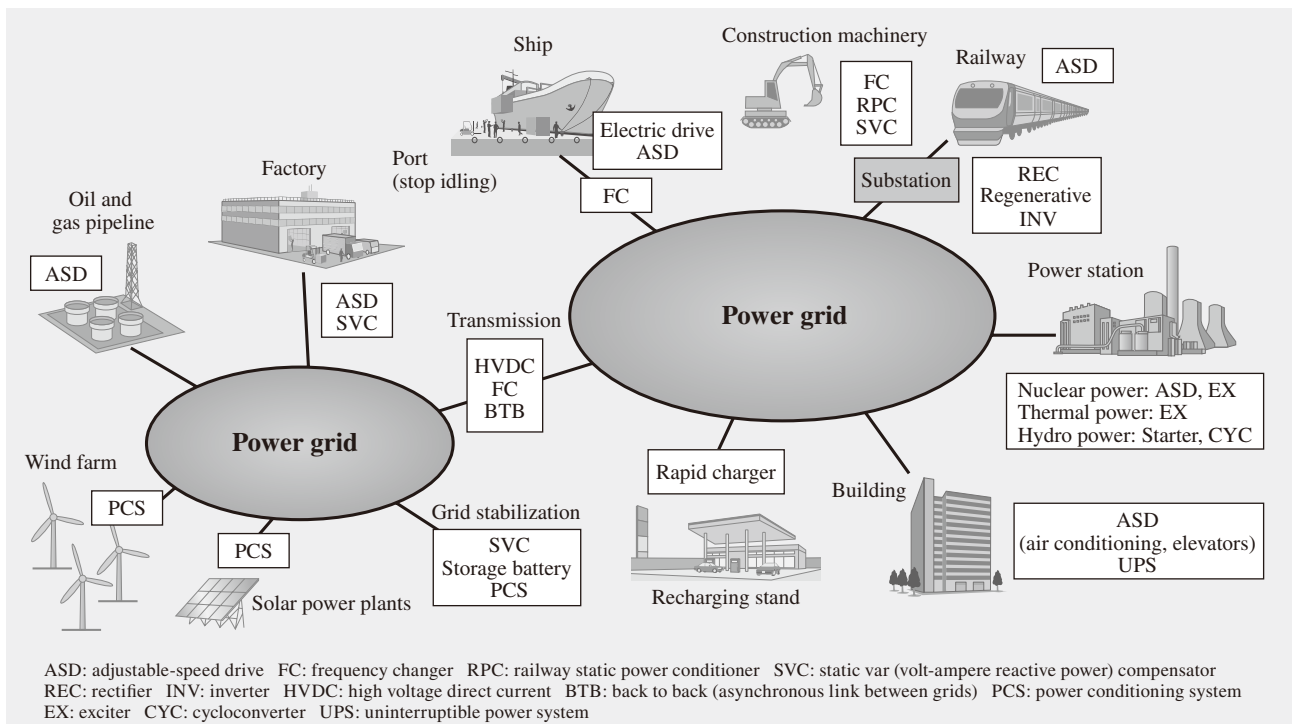

Fig. 1—Contribution of Power Electronics to CO<sub>2</sub> (carbon dioxide) Reduction in Power Generation and Industry. Power electronics has a major role to play in energy efficiency, stabilizing the connection of renewable energy to the grid, and enhancing the performance and functions of equipment.

technologies in its social innovation businesses which extend across power generation and general industry (see Fig. 1).

This article describes examples where power electronics and power devices have been used in renewable energy and industrial applications, and the technological prospects of the application for reduction of CO<sub>2</sub> emissions.

**CO<sub>2</sub> REDUCTION IN RENEWABLE ENERGY SECTOR**

Renewable energy is treated as a last resort of CO<sub>2</sub> reduction and the approach by its application at the government level is being executed. The newly installed capacity by the global market in 2008 reached 28 GW of wind power generation and 5.5 GW of solar power generation and the double-digit growth rate of the generations is expected to continue. This has drawn attention because this rapid increase in installed capacity can cause the problems for the quality of the power grid. The following sections describe what Hitachi is doing about the power quality problems associated with this large-scale installation of renewable energy.

**PCS for Wind Power**

Wind power generation has already become a commercially viable business and the installation of wind farms is accelerating in the US, China, and Europe in particular. In China, approximately 14 GW of new capacity was installed in 2009. Hitachi is pursuing its PCS (power conditioning system) business primarily in China.

Hitachi released a full converter type PCS for 100-kW-class PMGs (permanent-magnet generators) on the market in 2001. The 1.5- to 2.5-MW-class PCSs for doubly-fed induction generators that are the mainstay of Hitachi’s current business commenced production in 2006. A distinctive feature of these models is that their functions include an LVRT (low-voltage ride through) function for continuous operation during instantaneous voltage drops which complies with the grid codes of various countries (see Fig. 2). Meanwhile, Hitachi is also working on the ongoing development of PCSs with high availability that can cope with the anticipated future increase in the size of wind power generators.

**PCS for Solar Power**

In the field of solar power, large-scale solar power generation projects (known as “mega-solar”) are planned in various countries. For these mega-solar

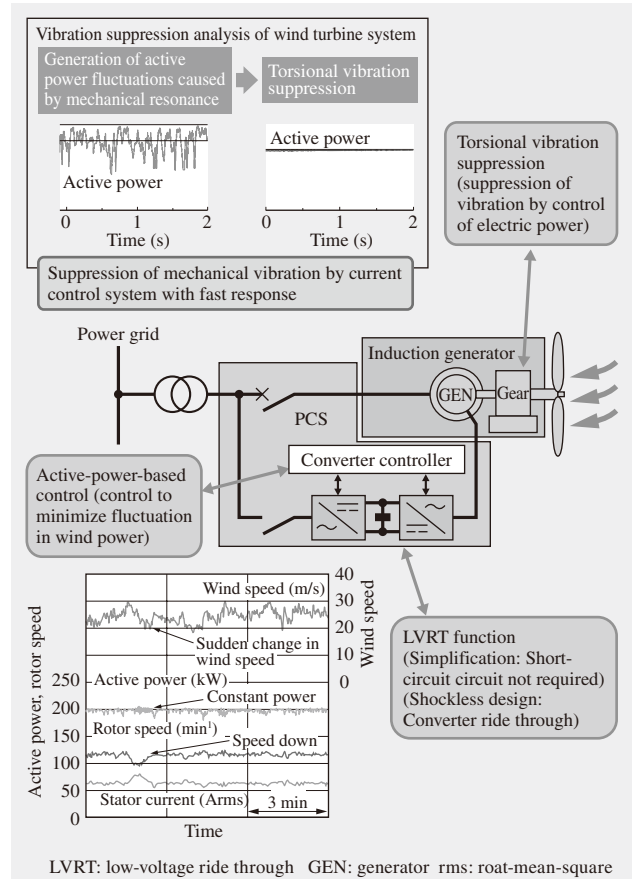

Fig. 2—Features of Converter Control System for Doubly-fed Induction Generators Used for Wind Power.

The system incorporates an LVRT function that complies with the grid code in various countries, torsional vibration suppression, and active-power-based control.



Fig. 3—PCS for Mega-solar. A large-capacity PCS (400 kW, 420 V, 3 phase) for large solar power generation systems (“mega-solar”).

projects, Hitachi supplies a 500-kW-class PCS with an LVRT function and a voltage fluctuation control function that is achieved by optimized reactive-power control. This PCS uses a transformer-less configuration with a maximum efficiency of more than 97% (see Fig. 3).

### Measures for Dealing with Expansion in Installation of Large-scale Renewable Energy

Although renewable energy sources such as wind and solar energy contribute to reduction of CO<sub>2</sub> emissions, the large-scale installation of such systems requires measures to maintain power quality because unstable energy sources will be connected to the power grid.

Hitachi is working on this problem in a wide range of fields including power electronics and system control technologies as well as components such as storage batteries (see Table 1). In the field of wind and solar energy in particular, in addition to the above-mentioned function implemented in the PCS for reducing voltage fluctuations, Hitachi is undertaking

TABLE 1. Hitachi's Solution to Large-scale Installation of Renewable Energy

*Measures for dealing with the issues of distributed power generation, surplus electricity, distribution, and the electric power system, and what Hitachi is doing in response are shown.*

Category	Measures	Hitachi's solution
Distributed power generation	Reduce voltage fluctuation.	PCS with function to reduce voltage fluctuation by optimizing reactive power
	Control output to reduce fluctuation in generated power.	Research into grid stabilization and power output maximization using coordinated wind farm control
Surplus electricity	Storage battery	PCS with load leveling and function to compensate for short-duration power fluctuations
		Long-life stationary VRLA batteries for power storage (LL series) Industrial Li-ion batteries
	Power storage hydro-power plant	Variable-speed pumped storage system
Distribution	SVC	Large-capacity SVC for flicker suppression
Electric power system	Interconnected system	Ultra-high-voltage DC interconnection system and power protection and control system (HVDC, FC, BTB)
	Interconnection between generation and distribution	Smart grid system

VRLA: valve-regulated lead-acid

research for stabilization and maximization of the output of an entire power plant through the cooperative control of distributed power generations as systems for wind farm, etc.

For the future, Hitachi will develop these technologies into a smart grid that can improve the stability of the electric power system through the interlinked control of each wind farm, mega-solar system, or other generation site from an energy management system.

### EFFICIENCY IMPROVEMENT TECHNOLOGIES FOR DRIVES AND UPS Drive Systems for General Industry

As a means of reducing CO<sub>2</sub> emissions to prevent global warming, the need to improve energy efficiency by using adjustable-speed drive to operate equipment such as fans and pumps at the optimum speed has strengthened in recent years. To meet this demand, Hitachi launches the multi-level IGBT inverter series of medium-voltage multi-level IGBT (insulated gate bipolar transistor) drives that can drive electric motors with rated voltages in the 3-kV and 6-kV classes directly without step-up transformers. Fig. 4 shows the product range.

Models rated up to 8 MVA are available for inverters with a 6-kV output voltage and Hitachi has developed a water-cooled five-level inverter to meet the demand for even larger capacities. Fig. 5 shows a picture of the inverter and its block diagram. This model connects two three-level inverters in series and uses a control method that can output five voltage levels. The configuration consists of two 30-MVA converter banks with a 7.2-kV output voltage and maximum output capacity of 60 MVA. Hitachi has also produced models with an 11-kV output for the global market.

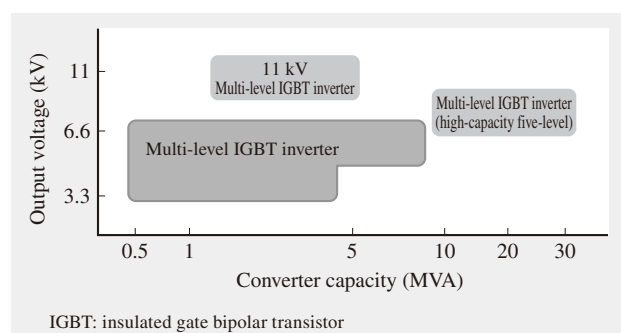

Fig. 4—Hitachi's High-voltage Direct Inverter Product Range. A new high-capacity five-level 11-kV model has been added to the existing 3-kV and 6-kV models in the multi-level IGBT inverter series.

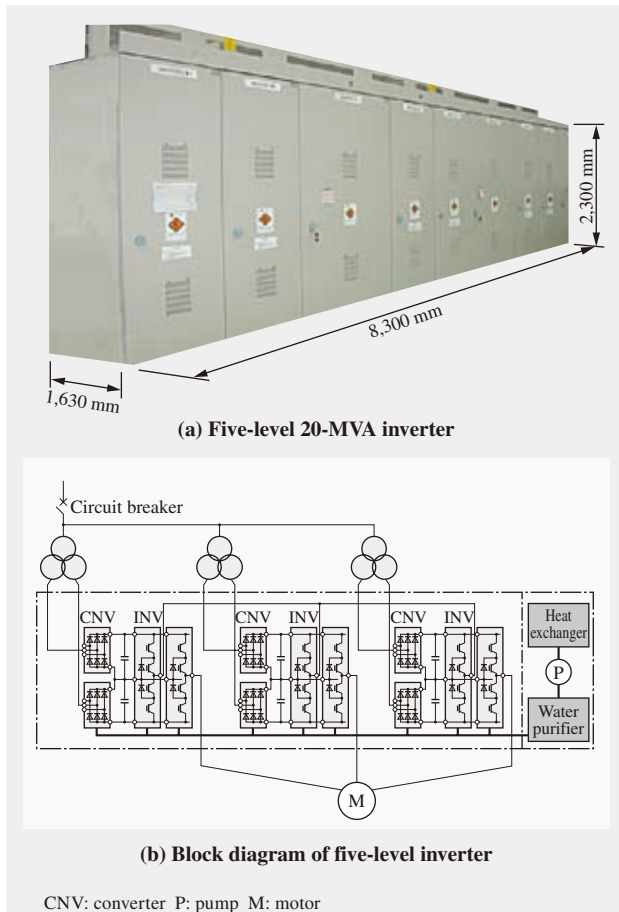

Fig. 5—High-capacity Water-cooled Five-level Inverter. A model featuring a control technique with five output-voltage levels was developed by connecting two three-level inverter units in series.

When installing an inverter, it is essential to select the optimum drive for the target plant to allow for the diversity and higher precision of customer equipment. Hitachi utilizes analysis technologies to improve converter efficiency and space factor with the aim of offering a total drive solution, including control techniques that reduce torque ripple in particular which can cause problems on the machinery. Hitachi also promotes its energy-conservation business which provides energy-efficiency services at no initial capital cost to the customer.

Hitachi has been expanding its product range and functions and has already contributed to energy conservation in many different sectors in the past. Hitachi also intends to expand the scope of applications in which drives can be used to improve energy efficiency by, among other things, entering the oil and gas industry and converting mechanical-drive mining dump trucks, ships, and other machinery to electrical drive.

## UPS

UPSs (uninterruptible power systems) are used to provide a reliable power to the information technology and communication systems that support our information-based society<sup>(1)</sup>. Not only is the importance of UPSs growing year by year, user needs are also expanding in sophisticated and diverse ways with demand for energy conservation and good economics as well as reliability. For example, the power dissipation in data center UPSs are in the range of 7 to 18% of total energy use which indicates a need for improvement<sup>(2), (3)</sup>.

Hitachi has improved the efficiency of its transformer-less UPS series of large UPSs through measures that include using 400 V as the input and output voltage and adopting a transformer-less scheme and reducing the losses in the UPS unit by more than 40% compared to the conventional model (the efficiency of the 400-kVA and 540-kVA models is better than 95%)<sup>(4)</sup>. With the adoption of a transformer-less scheme, the new UPS uses DC (direct current) transformer saturation suppressing control and a high-frequency filter circuit for functions such as prevention of DC component output and prevention of high-frequency leakage currents that in conventional UPSs were handled by a built-in insulating transformer. Because UPSs are commonly operated at 30 to 70% of their rated capacity, the UPS was designed to ensure high efficiency during normal operation with features that prevent loss of efficiency when operating at low load such as the selection of low-loss IGBTs, an appropriate switching frequency, and a good balance between iron loss and copper loss in the reactor coil.

Also, by using long-life parts, the system was designed to reduce the number of parts that require periodic replacement to achieve lower energy consumption, less waste, and lower running costs as well as higher efficiency (see Fig. 6).

For the future, Hitachi intends to improve UPS efficiency further through measures such as the use of low-loss switching elements, designing the switching circuit configuration and switching pattern in such a way as to reduce losses, and the use of reactor coils that incorporate low-loss magnetic substances. In Japan which has a extremely reliable electricity supply system by international standards, Hitachi also believes that, in addition to double conversion UPSs that are the main method currently used for large systems, these large systems can make greater use of line interactive UPSs that offer even higher efficiency and the company intends to expand its product range to include such configurations.



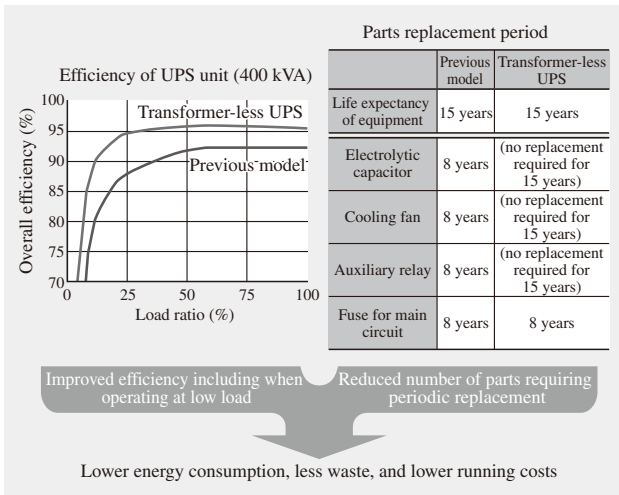

Fig. 6—Example Running Cost Savings Achieved through Higher Efficiency and Longer Component Life. Lower energy consumption, less waste, and lower running costs are achieved by making improvements to the efficiency that also cover the 30 to 70% load range common in actual operation and by reducing the number of parts that require periodic replacement.

### Frequency Converter for Anchored Ships at Port

Making greater use of idling stoppage for anchored ships is being planned at many ports as a way of reducing CO<sub>2</sub> emissions. Although large ships have traditionally needed to keep their engines running even while in port in order to generate electricity for the utilities in the ship, there is a desire to provide them with a power supply from land when the ships come alongside the quay in order to allow their engines to be shut down.

Because most ship power systems use 60 Hz, there is a need to use frequency conversion to convert the 50-Hz commercial power supply. The frequency converter needs to be in the 500 to 1,000-kVA range to have sufficient capacity to match the ship's requirements and Hitachi intends to modify its existing UPS products to develop a frequency converter model that uses semiconductor-based power conversion for this application.

## TECHNOLOGY OUTLOOK FOR POWER ELECTRONICS

### Power Electronics Technology for Energy Conservation

The scope of applications for power electronics technology is expanding rapidly to encompass things like new energy devices and electric drive systems with the aim of reducing CO<sub>2</sub> emissions. In addition to supporting energy-conservation products, power

electronics technology also needs to pursue greater efficiency in the conversion equipment itself.

Hitachi has developed: (1) multi-level technology such as a three-level NPC (neutral point clamped) inverter<sup>(5)</sup> and high-voltage direct inverter<sup>(6)</sup>, (2) predictive PWM (pulse width modulation) technology with low torque ripple even when operating at a low switching frequency<sup>(7)</sup>, and (3) snubberless technology. Future products planned by Hitachi include a highly efficient converter with optimized PWM pulses, a transformer-less converter, and a converter designed for filter-less operation.

Hitachi is also working on the use of SiC (silicon carbide) to improve converter efficiency and produces a power module using 3-kV-class SiC diodes that has demonstrated losses approximately 30% lower than the previous model in railway traction converters fed by an AC (alternating current) supply<sup>(8)</sup>.

### New Technology for Medium-power Industrial Converters and High-power Industry Converters

Hitachi has released a three-level NPC converter with IGBTs connected in series<sup>(9)</sup>. The product succeeded in achieving high capacity using general-purpose IGBTs by using active gate control to protect the series-connected IGBTs from over-voltage (see Fig. 7). The use of general-purpose IGBTs is expected to extend the life cycle of the product. To increase capacity further, Hitachi has released a 60-MVA-class five-level inverter based on the above three-level NPC converter and is working on extending the technology

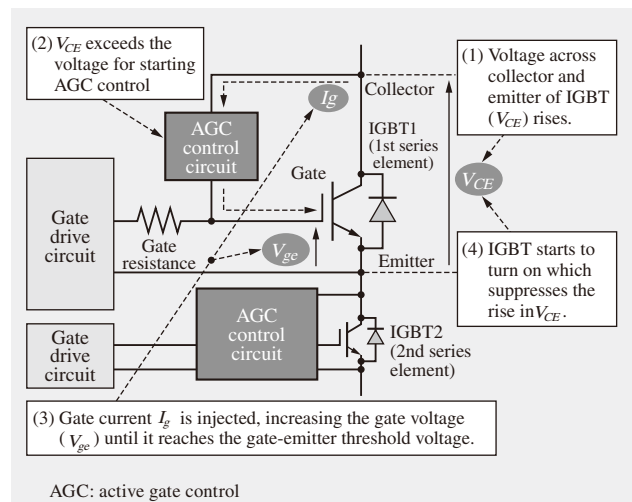

Fig. 7—Control Circuit for Active Gate Control. The serial-connected voltage divider is fine tuned by controlling the voltage between the emitter and collector of the IGBT.

to 100-MVA-class converters for the power industry, including medium- or high-voltage frequency converters and STATCOMs (static synchronous compensators). Compared to power industry conversion equipment that uses GCTs (gate commutated thyristors) and other thyristor devices, the features of active front end converters that use IGBTs include not requiring a special transformer and also excellent control performance with a high level of pulse flexibility.

In the future, most high-power voltage source converters for the power industry are expected to be multi-level converters such as MMCs (modular multi-level converters)<sup>(10)</sup> (see Fig. 8). MMCs consist of chopper-configured cells connected in cascade and, although subject to a number of issues, their advantages include very low harmonics, suitability for high-voltage operation, and the ability to be connected

to the grid without requiring a filter. Hitachi is working on commercializing these systems by verifying their operating principles in a mini-model with the aim of developing practical converters that use multi-level technology.

### TECHNOLOGY OUTLOOK FOR POWER DEVICES

Capable of both high capacity and low drive power operation, IGBTs are currently the main power device used to improve the efficiency and decrease the size of power electronics. IGBT chips consist of a large number of fine patterns called “cells” which are connected in parallel and provide the device with its basic performance. Fig. 9 (a) shows a diagram of the basic IGBT cell structure. The structure is a combination of a MOSFET (metal-oxide-semiconductor field-effect transistor) and PNP (positive-negative-positive) transistor and this allows the device to achieve both the simple drive and high-speed operation of a MOS (metal-oxide semiconductor) and the high capacity of a transistor (see Fig. 10).

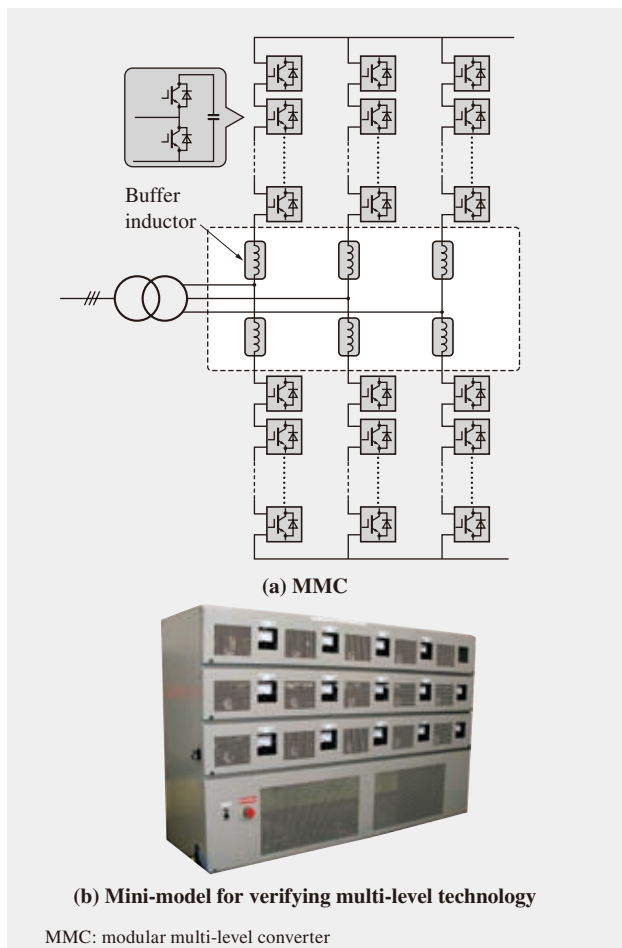

Fig. 8—Next-generation Multi-level Converter. Multi-level converters such as MMCs have excellent characteristics including low harmonics and suitability for high-voltage operation. Hitachi has performed control verification testing using a mini-model with the aim of developing practical converters.

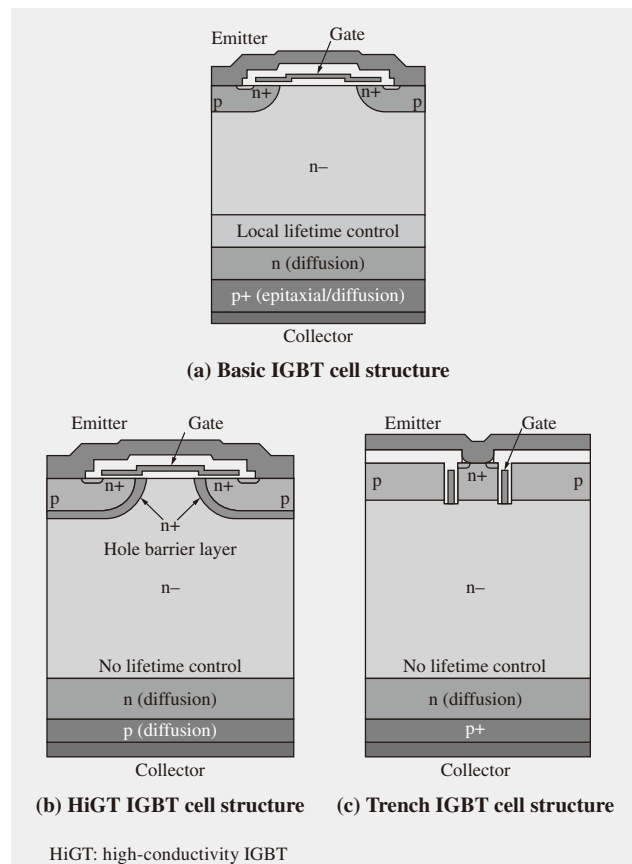

Fig. 9—Comparison of IGBT Cell Structures. Basic IGBT cell structure (a), HiGT IGBT cell structure (b), and trench IGBT cell structure (c) are shown.

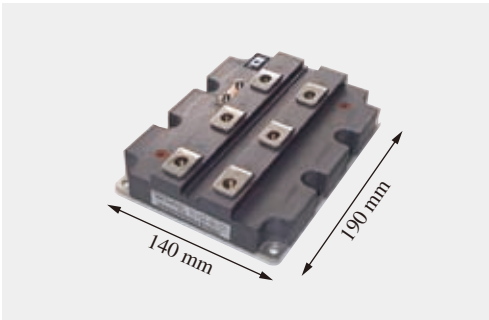

Fig. 10—High-capacity IGBT Module.  
1,200-A/3,300-V IGBT module is shown.

TABLE 2. Comparison of Materials for Power Device Substrates  
The characteristics of Si, SiC, and GaN are shown.

	Si	SiC	GaN
Band gap (eV)	1.1	3.3	3.4
Dielectric strength (MV/cm)	0.3	2.5	3.3
Minimum base layer thickness (relative to Si)	1	1/10	1/10

Si: silicon SiC: silicon carbide GaN: gallium nitride

To achieve the required high level of efficiency (low losses), Hitachi has been working on improvements which include adopting a trench design for the gate structure and greater miniaturization in the MOSFET part, and optimization of the current amplification factor for the transistor part [see Fig. 9 (c)]. Other successes include incorporating a carrier storage layer called HiGT (high-conductivity IGBT) into the cell to reduce the on voltage and improving the trade-off between the on voltage and switching loss by adopting thinner wafers [see Fig. 9 (b)].

Recently, SiC and GaN (gallium nitride) have been investigated as potential replacement materials for Si (silicon) in power devices. As indicated in Table 2, the features of these materials are that they have a larger energy band gap and higher dielectric strength than Si. These characteristics mean that these materials can operate at temperatures above 200°C compared to the 150 to 175°C maximum operating temperatures of existing power devices. Another feature is that conduction losses can be significantly reduced because they allow designs with short current-conduction paths, which is a requirement for high-voltage devices. Research is in progress focused in particular on developing devices that satisfy the small size, high mounting density, and high-temperature operation requirements of recent years.

In addition to IGBT-substitute switching devices using these materials, Hitachi is also working on the

development of prototype high-speed diodes that can contribute to improving equipment efficiency.

On the other hand, the use of modules that allow easy wiring has become the main approach in the field of high-capacity packaging techniques and these consist of a circuit formed on a ceramic substrate which is mounted on a base board that is used for cooling. Solder and aluminum wire are used for the internal connections. Accordingly, fatigue of materials is an important issue for the wiring due to the temperature fluctuations that occur when the equipment is in use, idle, or operating with a varying output. Hitachi can supply module structures that achieve high reliability through the use of wiring technologies that minimize the strain generated in the wiring and provide strong resistance to fatigue, these being the adoption of new materials [AlSiC (aluminum silicon carbide) and SiN] and the use of welding techniques.

Another issue is how to achieve high-speed switching without exacerbating electromagnetic noise. Because these devices are used in the analog circuit that forms the inverter's output stage switch, measures for dealing with switching noise are important. There have even been examples of systems that have adopted high-speed operation to minimize losses only to be unusable due to noise problems. It is anticipated that how to achieve easy control of the switching waveform will become an increasingly important challenge for device improvement in the future.

## CONCLUSIONS

This article has described examples where power electronics and power devices have been used in renewable energy and industrial applications, and the technological prospects of the application for reduction of CO<sub>2</sub> emissions.

Improvements including to the power devices and other components that support power electronics and to circuits and control techniques have led to smaller size, higher efficiency, and higher performance. Hitachi is working to advance the field of power electronics which is a key technology for reducing CO<sub>2</sub> emissions and achieving a more comfortable society.

## REFERENCES

- (1) “UPSs (Uninterruptible Power Supplies) Provide Reassurance in the Information Society,” The Japan Electrical Manufacturers’ Association (2009) in Japanese.
- (2) “Guidelines for Energy Efficient Data Centers,” The Green Grid, <http://www.thegreengrid.org/home>
- (3) Ministry of Internal Affairs and Communications, “Report of the Research Committee on ICT Policies for Dealing with the Problem of Global Warming” (Apr. 2008) in Japanese.
- (4) M. Toyota, “Technologies for Higher Efficiency and Smaller Size in Large Data Center UPSs,” *Electrical Review* (Mar. 2003) in Japanese.
- (5) M. Tobise et al., “Inverter-Fed AC Drive Systems for Steel Rolling Mills,” *Hitachi Review* **45**, pp. 299–304 (Oct. 1996).
- (6) N. Hasegawa et al., “Saving Energy and Alternative Energy Solutions Contributing to the Water Environment,” *Hitachi Hyoron* **89**, pp. 610–615 (Aug. 2007) in Japanese.
- (7) Y. Iwaji et al., “Evaluation of Characteristics of Predictive PWM Control,” 1997 National Conference of The Institute of Electrical Engineers of Japan, in Japanese.
- (8) K. Isihikawa et al., “Rolling Stock Inverters Using SiC Diodes,” 46th Railway Cyber Symposium, 506, (Nov. 2009) in Japanese.
- (9) M. Shigyo et al., “Inverter-fed AC Drive Systems for Hot Rolling Mills,” *Hitachi Hyoron* **90**, pp. 1014–1017 (Dec. 2008) in Japanese.
- (10) M. Hagiwara et al., “Control and Experiment of Pulsewidth-Modulated Modular Multilevel Converters,” *IEEE Transactions on Power Electronics* (July 2009).

## ABOUT THE AUTHORS

**Masashi Toyota**

*Joined Hitachi, Ltd. in 1981, and now works at the Automation & Control System Department, Information & Control Systems Company. He is currently engaged in the engineering of UPS and power electronics systems. Mr. Toyota is a member of The Institute of Electrical Engineers of Japan (IEEJ).*

**Zhi Long Liang**

*Joined Dongfang Electric Co., Ltd. in 1985, and now works at Dongfang Hitachi (Chengdu) Electric Control Equipments Co., Ltd. He is the Chairman of the company.*

**Yoshitoshi Akita**

*Joined Hitachi, Ltd. in 1991, and now works at the Drive System Center, Power Electronics & Drive Systems Division, Information & Control Systems Company. He is currently engaged in the design and development of motor drive systems. Mr. Akita is a member of IEEJ and The Society of Instrument and Control Engineers (SICE).*

**Hiroaki Miyata**

*Joined Hitachi, Ltd. in 1994, and now works at the Power Electronics Design Department, Power Electronics & Drive Systems Division, Information & Control Systems Company. He is currently engaged in the design and development of UPSs and grid connected inverters. Mr. Miyata is a member of IEEJ.*

**Shuji Kato**

*Joined Hitachi, Ltd. in 1990, and now works at the PS4 Unit, Department of Power Electronics System Research, Hitachi Research Laboratory. He is currently engaged in the research and development on high-power converters. Mr. Kato is a member of IEEJ, The Ceramic Society of Japan, and the International Council on Large Electric Systems (CIGRE).*

**Toshiki Kurosu**

*Joined Hitachi, Ltd. in 1975, and now works at the Power & Industrial Systems Division, Power Systems Company. He is currently engaged in the development of power devices. Mr. Kurosu is a member of IEEJ.*