

Featured Articles

Development of the Top-loading Washer Dryer

—Adding High Flow Rate Circulation Wash to Environmentally Conscious Features—

Kazutoshi Katane
 Hiroyasu Tamagawa
 Tetsushi Yoshida
 Shuji Aita

OVERVIEW: Currently, the major demands for top-loading washer dryers are energy & water savings, and larger capacity (environmentally conscious performance). The top-loading washer dryer released in FY2014 features high flow rate circulation wash and the high-end model with a washing capacity of 10 kg uses pumps to increase the circulation flow rate and has a new shape for the agitating blades to achieve both water-saving performance (that is, environmental consciousness) and washing ability at the same time. This model meets the needs of senior consumers for ease of use, and, in addition to the previously adopted large opening and shallow washing tub, also offers a “glass top design” for increased cleanability, an “assistance mechanism” that reduces the effort required to open and close the lid, and other features that increase the product’s user-friendliness even more.

INTRODUCTION

NEEDS for a top-loading washer dryer are varied, and include environmentally conscious performance in terms of saving energy and water, as well as high capacity, silent operation, washing ability, and user-friendliness in terms of ease of both laundry loading/unloading and operation. A user’s survey by household size and age regarding the priorities they have when purchasing a washer dryer shows that although environmentally conscious performance, washing ability, and other aspects of basic performance are given priority regardless of household size or age, ease of use tends to be given a higher priority the older the respondent. The survey also shows that, even as the number of households with fewer people has increased, the need for high-capacity models has also grown, due to people’s need for washing large items or washing a large number of items at the same time, regardless of the household size (see Figs. 1 and 2).

During the development of the FY2014 version of the top-loading washer dryer (high-end 10 kg model), Hitachi set a goal of providing “empathy value” in the sense that the product inspires an empathic connection with consumers. The model simultaneously achieves both water saving (environmental consciousness) and washing ability by applying a newly developed washing method made possible with its large 10-kg

capacity, in which a high flow of water is circulated. Furthermore, to respond to the needs of the senior generation in terms of ease of use, Hitachi has also focused on developing a “glass top design” with high cleanability (comprised of a single flat lid for the top surface, made out of reinforced glass), as well as an “assistance mechanism” that makes it easy to open or close the lid with minimal force. In addition, it aimed

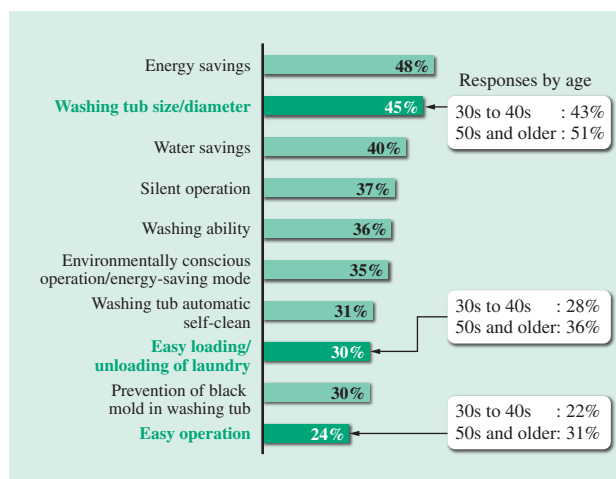

Fig. 1—Consumer Priorities when Purchasing a Top-loading Washer Dryer (Hitachi Survey from September 2013: n=410). Although a diverse range of needs exists with respect to washing machines, the need for ease of use increases according to the age of the respondent.

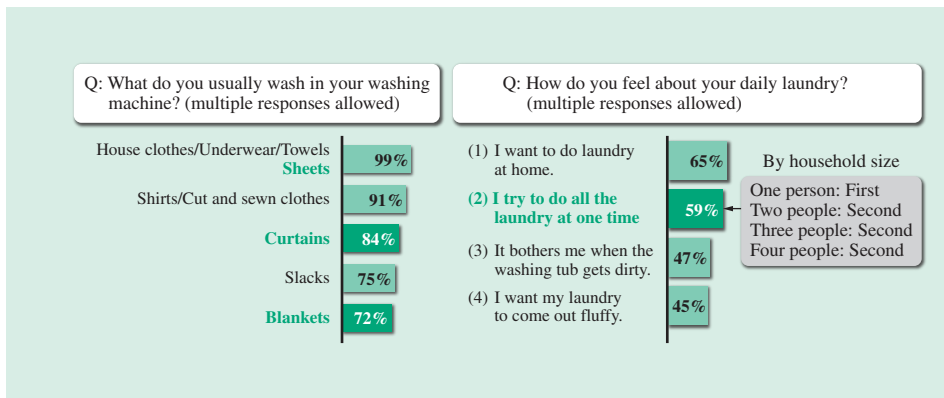

Fig. 2—Attitudes Regarding Laundry (Hitachi Survey from October 2013: n=832). Even as households grow smaller, high-capacity machines are becoming more necessary due to the need to wash suits, curtains, blankets, and other large items (left), or to wash in bulk to reduce washing frequency (right).



Fig. 3—BW-D10XTV FY2014 Top-loading Washer Dryer (10-kg Capacity).

Also offers ease of use, while achieving both water-saving performance and washing ability at the same time.

at providing a highly functional, high-quality product (see Fig. 3) utilizing vibration reduction technology that reduces unpleasant shaking and noise that occurs while the water is draining.

The following section describes the new washing method for combining water savings with washing ability, the vibration reduction technology, and the pleasingly easy to use design (including the glass top).

A WASHING METHOD THAT COMBINES WATER SAVINGS WITH HIGHER WASHING ABILITY

The Washing Method

The basic method used to wash laundry in a top-loading washer dryer is the “fill and wash,” whereby the washing tub is filled with a large quantity of water, and then the laundry is washed. Ever since it released its first model in FY2004, however, Hitachi has continued developing its unique washing method every year as a concept that enables the simultaneous achievement of

both water savings (by washing with a small amount of water) and a high level of washing ability.

The three key elements required to produce high washing ability are detergent, the way water is supplied, and mechanical force.

The development of the technology used in the “water-saving circulation pump” adopted for the high-end model released in FY2014 (BW-D10XTV) is described below.

Developing High Flow Rate Circulation Wash to Simultaneously Provide Both Water Savings and Washing Ability

To further improve the washing ability of its FY2014 product (BW-D10XTV), Hitachi made advances in the way water is supplied and the mechanical force components of its high flow rate circulation wash method while still saving water (environmental consciousness) at the same time.

(1) Advancing the way water is supplied

In order to further advance the way water is supplied, the circulation flow rate was increased with a “water-saving circulation pump,” and performance was improved by increasing the spray width of the circulated water. This caused the high flow of circulated water to evenly pour from the top over the clothes in the washing tub, which then caused the liquid detergent to more thoroughly penetrate and clean dirt off of the clothes. The increased circulation also soaks the clothes in water, thereby successfully incorporating the characteristics of a top-loading washing machine’s method of washing with a large amount of water while still saving water overall.

The achievement of a high flow rate involved issues in terms of both reducing pressure loss in the piping system and improving pump performance. Pressure loss was reduced by expanding the pipe diameter to an inner diameter of 30 mm (approximately 1.5 times the

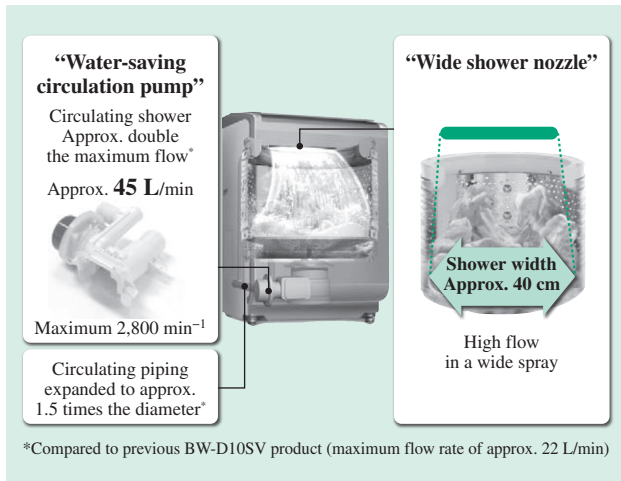

Fig. 4—High Flow Rate Circulation Wash
Washing ability is improved by circulating a small amount of water with a “water-saving circulation pump” and spraying water evenly over clothes with a “wide shower nozzle.”

previous ratio*), which is the maximum size that can be fit within the current body. Furthermore, pressure loss was also reduced in parts where the pipe bends and other places where the flow becomes complex inside the piping, for a total reduction in pressure loss of approximately 26% for the entire piping system*.

In terms of pump performance, measures such as increasing the efficiency of the impeller shape successfully enabled operating the circulation pump motor at a rotation speed of approximately 1.2 times the previous ratio (2,300 min⁻¹ increased to 2,800 min⁻¹)*.

Through these modifications, it was possible to achieve a maximum circulation flow rate of approximately 45 L/min, which amounts to approximately double the previous ratio* (see Fig. 4), all while still using a small amount of water (standard water usage of 86 L when laundering 10 kg).

Hitachi also developed the high flow rate wide shower to distribute the flow of circulated water throughout a wide range inside the washing tub, and this enables the uniform permeation of clothes with water regardless of the load size (see Fig. 5).

(2) Advances in mechanical force

In order to achieve advances in the mechanical force, Hitachi developed a new X-shaped agitator blade that improves performance. Each time the agitating blades reverse spinning direction at the bottom of the washing tub, the clothes are moved up and down (washing through pushing, beating, and kneading), drawn inward, shifted from top to bottom, and pushed outward. Movement of the clothes was improved inside the washing tub in the inward, outward, upward, and downward directions (see Fig. 6).

The aforementioned advancements in the way water is supplied and the mechanical force were used to achieve the new high flow rate circulation wash method. High flow rate circulation wash improves washing performance by approximately 5% while still using the extremely small amount of water (86 L) that is required for a top-loading washer dryer*, and at the same time reduces uneven washing by approximately 20%*. Although this method requires power to operate, because it uses a pump, it lowers the total running costs by reducing the required amount of water.

VIBRATION REDUCTION TECHNOLOGY FOR USE IN TOP-LOADING WASHER DRYERS

This section describes the vibration-reduction technology used to maintain the consumer’s level of comfort.

* Compared to the FY2013 product, BW-D10SV.

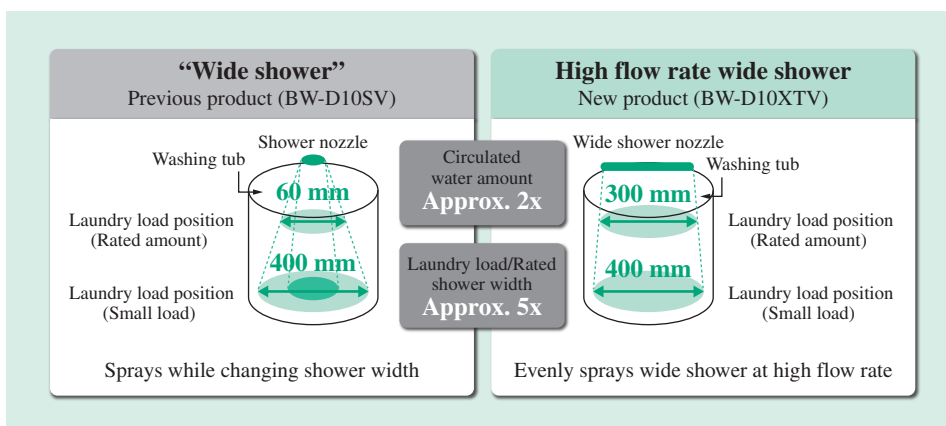

Fig. 5—High Flow Rate Wide Shower
Water is uniformly sprayed over clothes at a high flow rate regardless of load size.

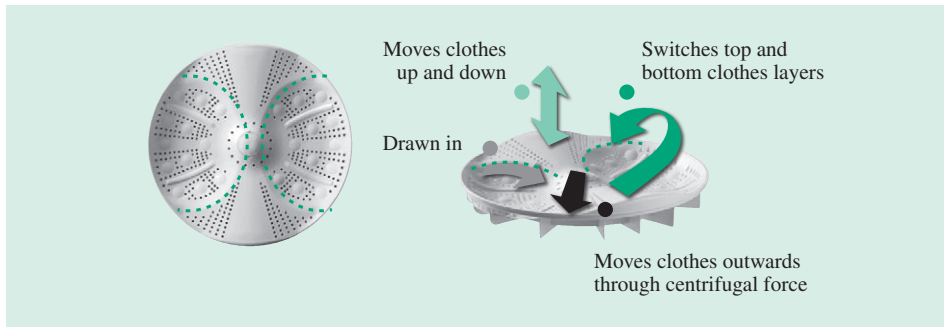

Fig. 6—New X-shaped Agitating Blades.

In addition to the effects of “pushing, beating, and kneading”, which have been previously adopted, the new X-shaped blades are improved to add movement in the inward, outward, upward, and downward directions.

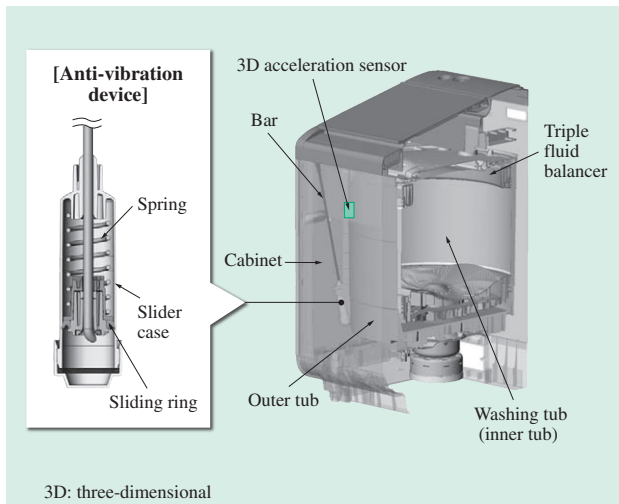

Fig. 7—Overview of Top-loading Washer Dryer Structure. The outer tub is suspended from the cabinet using four bars. In order to reduce vibrations, the bars are equipped with vibration isolation and fluid balancers. 3D acceleration sensors are used to constantly monitor vibrations.

The low-vibration structure of the top-loading washer dryer is shown in Fig. 7. The liquid inside the triple fluid balancer shown in the diagram reduces the unbalancing effect of the clothes by moving to the opposite side when it occurs. When stratification occurs in the radial direction, the effect, which is equivalent to including multiple fluid balancers, grows stronger. The outer tub is suspended from the cabinet with four bars. Anti-vibration devices are attached to the bottom of these bars in order to provide the outer tub with flexible support and a damping effect, while springs flexibly support the weight of the outer tub.

Consumers ordinarily wash a mixture of clothes that have a variety of different sizes and cloth types. For this reason, the amount of water content will also differ depending on the clothes, and uniformly pressing the mass of the clothes against the inside of the washing tub during spin drying becomes a challenge when it comes to reducing vibration. Also, even if the mass is evenly distributed at the start of

spin drying, the clothes can become increasingly unbalanced as moisture is removed. To solve this, a three-dimensional (3D) acceleration sensor is used to constantly detect complicated vibrations in the outer tub during spin drying, and to control the operation in such a way as to reduce the vibrations.

IMPROVEMENTS IN EASE OF USE

Hitachi has worked to develop a wide range of improvements in terms of ease of use, including cleanability, ease of opening/closing the lid, and the user interface (control panel).

Glass Top Design

The easy-to-clean “glass top design” was developed by forming a single large lid from tempered glass in a flat shape, with no irregularities or gaps (see Fig. 8).

Issues during the development of the “glass top design” included avoiding damage to the glass by falling objects, etc., durability against scratches, and other reliability factors, so a 4.0 mm thick sheet of tempered glass was used. In addition, the inclusion of an air layer between the glass and the base parts allows for deformation that may occur when a load is placed on the glass, this feature improves both the strength and the durability even further. Drop tests



Fig. 8—Glass Top Design. The flat “glass top design” makes it easy to wipe off dirt.

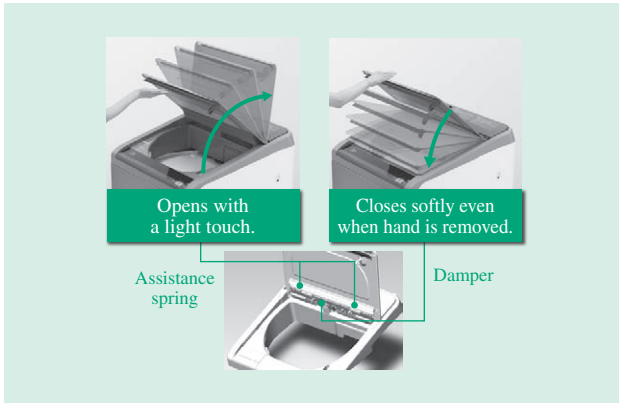

Fig. 9—Lid Opening and Closing “Assistance Mechanism.” Dampers and assistance springs enable the lid to be smoothly opened and closed with a small amount of force.

as established by Japanese Industrial Standards (JIS) confirmed that when this glass top is incorporated into a washing machine, dropping a 1-kg iron ball from approximately three times the required height (3 m) does not damage the glass.

Lid Opening/Closing “Assistance Mechanism”

Since the lid is heavier due to adoption of tempered glass, an “assistance mechanism” was developed to make it easier to open and close, with two types of dampers and assistance springs included on the hinge, in the opening and closing directions. This mechanism successfully reduces the amount of force required to open or close the lid from the approximately 22 N required for the previous type (BW-D10SV, the FY2013 version of the product), to approximately 7 N for the glass lid, or about one third the force. Furthermore, if the user’s hand loses its grip while closing the lid, a damper will take over once the lid reaches a predetermined angle to adequately decelerate the lid before it closes (see Fig. 9).

“Touch Panel,” “Favorites” Button, and “Detergent Insertion Port”

For the user interface, a touch panel was implemented with a display that stays on only while the power is on (see Fig. 10, left). The control panel was moved from the previous position in the center to the front of the lid, and this proximity makes it easier to see and operate the device without the need to extend the arms. In addition, to save the effort of selecting settings, a new “Favorites” button was added that can be used to remember the user’s three favorite operation course settings. By registering the most frequently

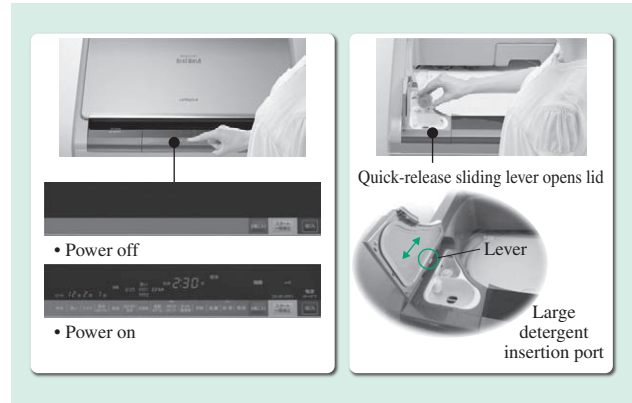

Fig. 10—Control Panel and Detergent Insertion Port. The control panel (touch panel) located in front is more user-friendly (left), while the wider aperture of the detergent insertion port makes it easier to insert detergent and other agents (right).

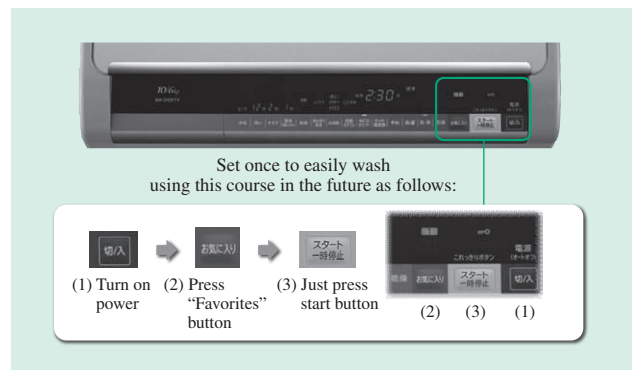

Fig. 11—“Favorites” Button. Favorite washing course, can be easily selected after setting them once.

used operation courses, all the user needs to do to start the washing operation is to press three buttons: the power on/off button, “Favorites,” and then start/stop (see Fig. 11).

The insertion ports for the detergent and for the softening agent (fabric softener) have been expanded in size and located up front to make it easier to insert the detergent and other agents. Furthermore, the detergent tray and detergent lid are constructed in such a way that they can be removed and washed if the area around the insertion port becomes dirty (see Fig. 10, right).

CONCLUSIONS

Hitachi has brought to life various innovations in the washing machine market by aggressively pursuing “values” that the consumer finds attractive, including an automatic tub-cleaning function that cleans the

washing tub after each operation, and a “Wind Iron” function that removes wrinkles using jet air in a front-loading washer dryer.

Hitachi will continue to pursue the values that customers seek.

REFERENCE

- (1) Y. Ishii, “What to Build? —Giving Form to the Customer’s Latent Needs,” *Hitachi Hyoron* **91**, 4, pp. 338—343 (Apr. 2009) in Japanese.

ABOUT THE AUTHORS



Kazutoshi Katane

Design Department 1, Taga Home Appliance Works, Home Appliance Group, Hitachi Appliance, Inc. He is currently engaged in the design and development of washing machines.



Hiroyasu Tamagawa

Utility Products Planning Department, Products Planning Division, Hitachi Appliances, Inc. He is currently engaged in the planning of washing machine products.



Tetsushi Yoshida

Production Engineering Department, Taga Home Appliance Works, Home Appliance Group, Hitachi Appliances, Inc. He is currently engaged in the development of washing machines.



Shuji Aita

Department of Home Appliances Research, Mechanical Engineering Research Center, Hitachi Research Laboratory, Hitachi, Ltd. He is currently engaged in the research and development of washing machines. Mr. Aita is a member of The Japan Society of Mechanical Engineers.