

Featured Articles

Trends in Design and Associated IP Management

Atsushi Katayama
 Masayuki Ohki
 Tatsuya Tokunaga
 Yukinobu Maruyama
 Masashi Tsukamoto
 Yumiko Tanuma
 Kazuya Narahashi

OVERVIEW: Hitachi’s involvement with design and IP can be thought of as evolving through three different phases: (1) an era of equipment design, aimed primarily at home appliances; (2) an era of information design, based on IT devices, systems, and interfaces; and (3) an era of social services and solutions, and of innovation. The scope of design expanded through each of these eras, leading to ongoing changes in the nature of IP management. In the era of equipment design, IP management was primarily concerned with using design patent rights to protect the externally visible features of products, whereas in the era of information design, the focus was on protecting product designs using patent rights as well as design patent rights. The era of services, solutions, and innovation was also a time of “collaborative creation with customers,” meaning working in cooperation with customer companies to create ideas, with important considerations being the development of new design techniques for this purpose and the protection of rights. This article describes representative examples of IP strategies adopted to deal with this expansion in the scope of design.

INTRODUCTION

FROM when it was first established in 1957 to the 1980s, intellectual property (IP) management at the Design Division*, Hitachi, Ltd. (see Fig. 1) was primarily concerned with using design patent rights to protect the externally visible features of home appliances and other consumer products and equipment.

* Department name as of March 2015.

Subsequently, as products became more varied to satisfy increasingly diverse user needs, enhancements to usability and functionality became important product features, and an effective IP strategy was one that helped maintain product competitiveness by using patent rights to protect the designs that provide ease-of-use. Accordingly, the Design Division has been working with the Intellectual Property Division from a comparatively early stage on ways of using patent rights to protect designs.

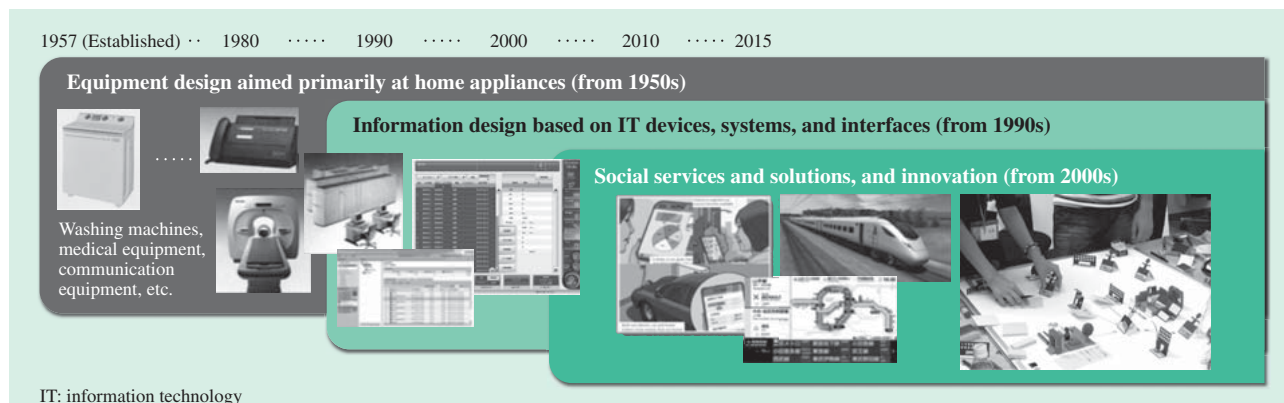

Fig. 1—Trends in Design. Hitachi’s involvement with design and intellectual property (IP) can be broadly divided into three different phases, with the scope of design increasing over time.

With the rapid spread of information technology (IT) since the mid-1990s, Hitachi has been strengthening its usability designs for things like enabling the intuitive interpretation of operation screens or improving their intelligibility, and for its interactive designs that seek to provide bi-directionality in the operation interface between humans and machines. For these “information designs,” Hitachi has adopted a strategy that combines design patent rights and patent rights, with design patent rights used to protect graphics and patent rights used to protect things like screen transitions and data structure concepts.

Since the mid-2000s, the scope of design has expanded to encompass the subjective values that users perceive through products and services^{(1), (2)}, with the development of proprietary design methodologies for use in product development. In recent years, in relation to the services and solutions or product developments of Hitachi’s Social Innovation Business, it has also become necessary to promote these design methodologies both inside and outside the company. Accordingly a shift is underway in IP strategy away from having the protection of designs from competitors as its primary consideration and toward strategies that promote Hitachi’s design methodologies to customers.

IP STRATEGY FOR ERA OF HOME APPLIANCES AND OTHER EQUIPMENT DESIGN

The focus of IP management during this era was the use of design patent rights to protect the external design of home appliances such as refrigerators, washing machines, and televisions (see Fig. 2, Japanese design

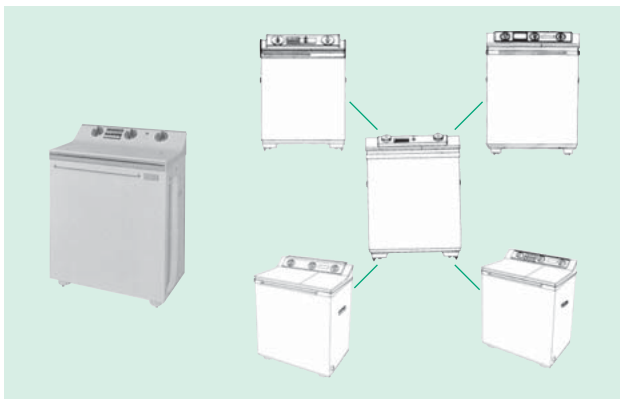

Fig. 2—Best-selling Washing Machine (Dual-tank) and Associated Portfolio of Design Patent Rights. Hitachi utilized the similar design registration system to obtain rights to associated designs as well as the product design.

registration No. 324027 and others). A feature of the strategy for applying for design patent rights was that it made active use of the similar design registration system to obtain rights in the form of “principal designs” for the designs used in product development, and as “similar designs” for associated peripheral designs and partial model upgrades. In addition to providing broad-based protection for Hitachi designs, this practice involved a strategy for preventing competitors from copying equipment designs through measures such as issuing warnings based on design patent rights. For a considerable period of time, this practice remained the main way in which design patent rights were used to protect designs.

In the 1980s, based on a background of increasing diversity and sophistication in product functions and the intensification of competition between companies, the challenges for product design were to achieve better operation and excellent usability while still holding down development costs. In the case of home appliances in particular, numerous ideas were investigated for promoting routine ease-of-use in clearly intelligible terms. Measures relating to the structural design of products were particularly effective for this.

Fig. 3 shows a vacuum cleaner suction head developed with a focus on usability. A problem with previous vacuum cleaner heads was that they were not good at cleaning along walls or confined spaces because of their very limited horizontal turning angle.



Fig. 3—Multi-angle Head. The vacuum cleaner became a hit product thanks to a suction head that rotates in response to twisting the hose grip.

In response, Hitachi devised a mechanism that could turn the head 180° to the left or right by twisting the cleaner hose's handgrip, thereby making it easy to orient the head for cleaning along walls or in confined spaces.

Fig. 4 shows the ingenious design for the joint between the head and hose that enables the head to rotate 180° to the left or right with ease. This resulted in the “multi-angle head,” with this movement being the core product concept.

Hitachi adopted an IP strategy for the idea behind the multi-angle head that used design patent rights to protect its external design and patent rights to protect the head mechanism. This provided multi-faceted protection for the product and discouraged copying by competitors (Japanese patent No. 2963413 and Japanese design registration No. 1026499).

Hitachi has continued applying for patents as it has made further product enhancements. Hitachi has acquired approximately 50 design patent rights and patent rights for the multi-angle head, thereby helping protect it against copying by competitors, and increasing sales.

Since the 1980s, the scope of design has expanded to encompass non-consumer products such as IT equipment, rolling stock, medical equipment, and elevators and escalators. An IP strategy that combines both design patent rights and patent rights has been widely deployed, being particularly effective for equipment and system products that include display screens. This IP strategy will be more fully adopted with the arrival of the information design era.

IP STRATEGY FOR ERA OF INFORMATION DESIGN

As the era of information design, the 1990s were characterized by the use of IT to enhance product functions. It was during this period that graphical user interface (GUI) design became important. It was also during this time that the Design Division established a department to undertake specialized research into usability design and utilize it in product development. Subsequently, in the 2000s, the department worked with Central Research Laboratory, Hitachi, Ltd. on experimental work on interactive designs that involved research into operational performance achieved through the use of IT for interaction between humans and machines. Hitachi undertook an active program of patent applications for the results of this research, establishing a portfolio of approximately 40 patents.

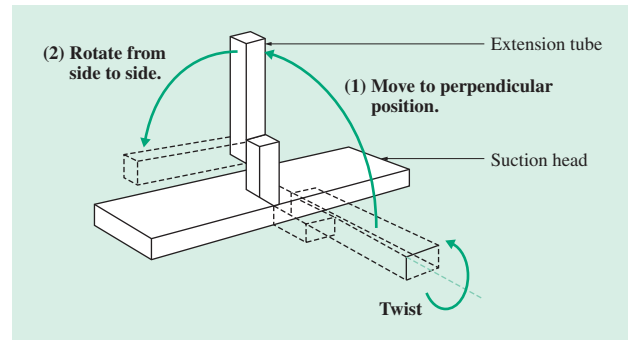

Fig. 4—Head Rotation Mechanism.

A mechanism for rotating the suction head when the hose grip is twisted was created by fitting a joint that enables the extension tube to move relative to the suction head, both perpendicularly (1) and from side to side (2).

This section describes the design of screens used in analyzers, this being a representative example of the application of information design to a product. Normally, the important considerations for screen design include not only the visual appeal of the graphics but also its ease-of-use (how easy the screen is to view and how clearly it presents information). The information used in special-purpose instruments such as analyzers is more high-level and complex than for home appliances and other consumer devices, and the laboratory technicians who perform analyses need to handle a large amount of information. In addition to the appearance and ease-of-use of icons and other controls, and data structures, screen transitions, and other features designed with an emphasis on clarity of purpose, ideas that relate to challenges specific to special-purpose instruments, such as indicators for showing things like analysis progress and equipment status, are also important to the GUI design for these instruments. Hitachi has built up a solid IP portfolio through an IP strategy that combines design patent rights and patent rights, using design patent rights to protect graphical characteristics, and patent rights to protect the concepts behind things like ease-of-use, data structures, and screen transitions.

Fig. 5 shows two operation screens for a clinical analyzer. The left side of the screen on the left displays the contents of the specimen rack in a way that mimics the physical instrument, and the right displays detailed information for the selected specimen rack. In the screen on the right, the left side displays a specimen list with a menu display button appearing next to the selected specimen in the list. Clicking this menu display button displays an array of menu buttons corresponding to the available operations for that specimen.

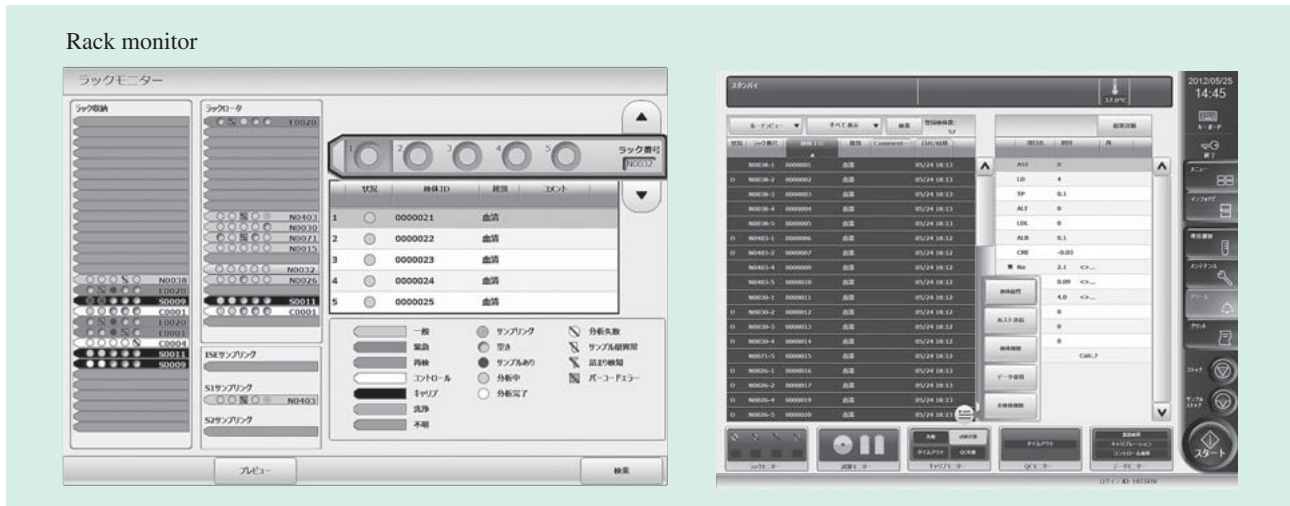

Fig. 5—Clinical Analyzer Operation Screens.

The layout of operation screens mimics the actual analyzer to make operation easy to understand.

By using this screen layout, which mimics the physical design, Hitachi succeeded in developing a clinical analyzer that allows laboratory technicians to check on analysis progress from remote locations, and with operation that is easy to understand. The screen design is protected by both patent rights and design patent rights (Japanese patent No. 5476389 and Japanese design registration No. 1408834).

ERA OF SOCIAL SERVICES, SOLUTIONS, AND INNOVATION, AND ROLE OF IP

As indicated by the expression, “design stories from things,” the late 2000s was a time of transition away from the highly product-oriented design approach of the past and toward a design approach that focused on the value perceived by customers and other end users through products, services, and solutions. This involved the adoption of new development processes featuring the participation by design, research and development, and business units together with customers and other end users in the collaborative creation of new value. The challenge was to establish technological methodologies for collaborative creation with customers through the ability of design to make things visible, with this representing one technique for integrating a variety of different knowledge. In addition to researching these methodologies, the Design Division developed a number of collaborative creation tools and introduced them into practical use.

One strategy for IP management is to use trademark rights for protection along with design patent rights, patent rights, and similar. There are examples of

consulting companies, think tanks, and similar organizations registering their methodologies as trademarks, and Hitachi recognized that this would also be beneficial for promoting its design methodologies and other tools outside the company.

The following sections describe IP management at the Design Division, including the trademark rights to its representative design methodologies and tools.

Experience Design at Hitachi

Experience design is a design methodology that Hitachi has been building up over the last decade or so.

One of its major features is the rigorous use of ethnography⁽³⁾ to identify the genuine issues and latent needs at customer workplaces, and its techniques for describing the future form that users want products to take and how customers should go about their operations. The stakeholders present in a workplace, and who interact there, include end users, workers, and the staff who manage and operate equipment and systems. Factors such as the problems that occur with equipment and other systems used in the workplace and the nature of the services available vary over time, as do the severity of problems. Experience design is an approach to design that identifies the issues to be resolved from increasingly complex problems in order to develop services and other solutions.

The following describes some of the typical design tools used for experience design.

(1) Customer journey map

A customer journey map is a tool that uses a time-series format to show how workers and the people who utilize available services interact with equipment,

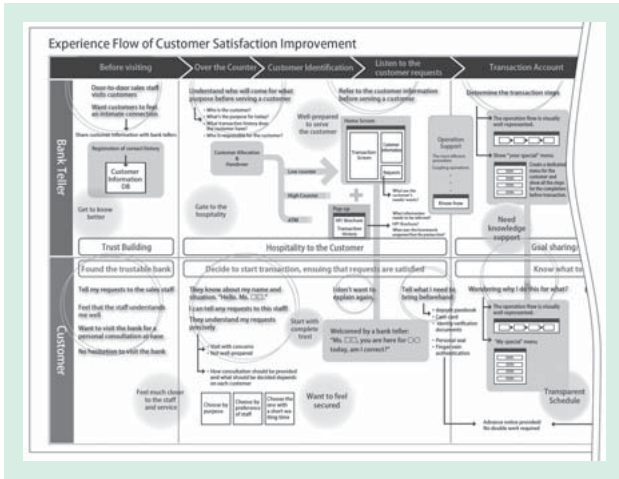

Fig. 6—Customer Journey Map. This example map was created to identify service requirements and other issues by presenting the events experienced by bank tellers and customers in a time-series format.

systems, and services, and to identify things like the problems inherent in equipment and systems or the requirements of services from a record of the events that people experience. Fig. 6 shows an example customer journey map.

While they can take many different forms, customer journey maps are useful tools for enabling the people involved in development to share information about issues by recording specific details about the distinctive events that occur, depending on what is being studied and the type of activity involved.

(2) Stakeholder map

Fig. 7 shows an example of a service study that uses a stakeholder map.



Fig. 7—Example Service Study Using Stakeholder Map. The stakeholder map encourages discussion of the service model by allowing participants to move origami models around as they work.

A stakeholder map is a tool that enables participants to study a service model and engage in discussion by using *origami* models to represent the elements, such as people or buildings, that form part of the hypothetical service, and recording information such as the role and relationships of each element. What is unique about a stakeholder map is that it is a simple process that feels like a game in which participants can inspire each other through discussions that transcend their different fields of expertise⁽⁴⁾.

The Design Division developed the customer journey map, stakeholder map, and other tools by itself. They are used in a wide variety of situations. One of the challenges for these tools is to use IT to improve efficiency, and further development continues with this objective. For the stakeholder map, for example, Hitachi has developed technology that uses image recognition techniques to record the relationships for each stakeholder in a system to facilitate things like record-taking and modifications in the model-making stage, and to display this information automatically, while also enabling things like moving the *origami* or physically recording notes in order to continue encouraging the generation of ideas through discussion. This technology has been patented (Japanese patent No. 5174563).

IP Protection of Design Tools

Techniques such as the customer journey map and stakeholder map are design tools for working with customers and other stakeholders to develop things like products and services. While IP management still needs to prevent copying and imitation by competitors, a strategy is required that can promote Hitachi’s “experience design” to customers and encourage collaborative creation. Accordingly, Hitachi uses trademark rights as well as design patent rights and patent rights to protect its design tools. That is, it seeks to establish a brand by obtaining trademark rights to design tool names. The following are two examples.

(1) Customer journey map (ExperienceTable): Japanese trademark No. 5310747

(2) Stakeholder map (BusinessOrigami): Japanese trademark No. 5231393

CONCLUSIONS

The Social Innovation Business that Hitachi is strengthening seeks to meet the various challenges facing society by gathering knowledge from many people, including customers. Accordingly, along with

its past role of protecting Hitachi IP and preventing copying by competitors, the IP strategy for the Social Innovation Business also needs to make large numbers of people, including customers, aware of Hitachi IP and encourage them to use it. Along with a deepening of collaborative creation with customers, Hitachi plans in the future to supply value to customers by using a wide variety of IP, including copyright and trade secrets as well as patent rights, design patent rights, and trademark rights.

REFERENCES

- (1) J. Furuya, H. Kitagawa, and K. Kashimura, "Experience Design for Enterprise Value Improvement," *Hitachi Hyoron* **89**, pp. 726–729 (Sep. 2007) in Japanese.
- (2) "Experience Design for Social Innovation," *Hitachi Review* **62**, (Sep. 2013).
- (3) K. Kashimura et al., "Design Approach based on Social Science for Social Innovation Business," *Hitachi Review* **63**, pp. 548–559 (Nov. 2014).
- (4) Hitachi, Ltd., "Experiential Value: Introduce and Illicit Ideas (Business Origami)," http://www.hitachi.com/rd/portal/contents/design/business_origami/index.html

ABOUT THE AUTHORS



Atsushi Katayama
Central Research Laboratory, Research & Development Group, Hitachi, Ltd. He is currently engaged in design planning.



Masayuki Ohki
Product Design Department, Global Center for Social Innovation - Tokyo, Research & Development Group, Hitachi, Ltd. He is currently engaged in the industrial design of vacuum cleaners and air purifiers (as of March 2015).



Tatsuya Tokunaga
Hitachi America, Ltd. He is currently engaged in the development of user interface designs such as analytical systems and railway systems (as of March 2015).



Yukinobu Maruyama
Hitachi Europe Ltd. He is currently engaged in service design, such as energy management systems, railway systems, and healthcare systems.



Masashi Tsukamoto
Design & Trademark Center, IP Business Division, Intellectual Property Division, Hitachi, Ltd. He is currently engaged in the management of design and trademark matters. Mr. Tsukamoto is also a patent attorney (Japan).



Yumiko Tanuma
Design & Trademark Center, IP Business Division, Intellectual Property Division, Hitachi, Ltd. She is currently engaged in the management of design matters.



Kazuya Narahashi
Intellectual Property Center, Hitachi (China) Ltd. He is currently engaged in the management of patent and design matters in China. Mr. Narahashi is also a patent attorney (Japan).