

Transportation Systems

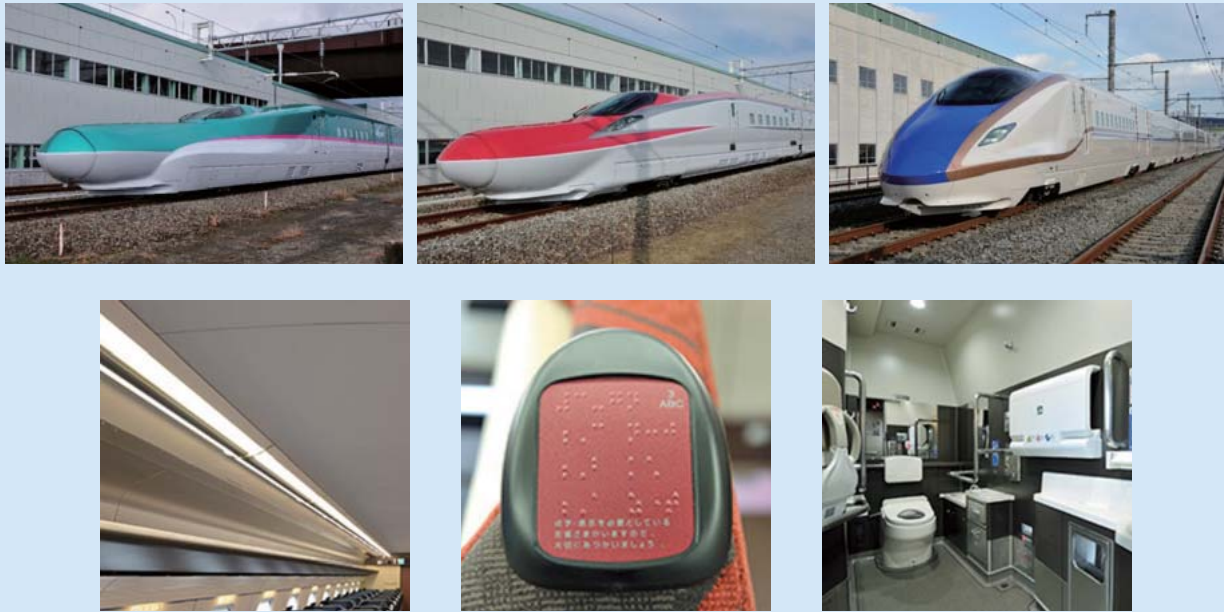

1 Latest Shinkansen rolling stock and interior fittings

1 East Japan Railway Company and West Japan Railway Company Rolling Stock for Hokuriku Shinkansen

The Series E5 rolling stock for the Hokuriku Shinkansen and the Series E6 for the Akita Shinkansen have entered service, becoming the first such trains in Japan to achieve 320 km/h in commercial operation. Meanwhile, the Series E7 and W7, which will be introduced in March 2015 when the Hokuriku Shinkansen is extended to include services to Kanazawa will operate at 260 km/h, with E7 services to Nagano being introduced first. These new Shinkansen rolling stock have been supplied to the East Japan Railway Company and West Japan Railway Company.

The Series E7 and W7 Shinkansen rolling stock incorporate a variety of new technologies, including improvements to ride comfort and stopping performance. Of particular note is that the Hokuriku Shinkansen rolling stock needs to use both 50-Hz and 60-Hz power systems on different sections of track. In addition to the use of light-emitting diode (LED) lighting throughout the trains, interior comfort has been improved by the use of universal design, the provision of power sockets on all passenger seating, and barrier-free multi-function toilets. The addition of these new fittings provides for comfortable long-distance journeys.

2 Series 60000 Rolling Stock for Tobu Railway Co., Ltd.

Hitachi has supplied new Series 60000 rolling stock to Tobu Railway Co., Ltd. for the Tobu Urban Park Line (Noda Line).

The trains are the first new series to be added since the line commenced operation. Their design is based on the Series 50000 and builds on its concept of building next-generation trains that are kind to people and the environment, adding improvements to comfort and environmental performance along with barrier-free



2 Series 60000 rolling stock for Tobu Railway Co., Ltd.

(accessibility) features.

The carbodies have a double-skin aluminum alloy structure that reduces weight without compromising strength. The traction drive system uses small and lightweight inverters and highly efficient fully enclosed fan-cooled electric motors to significantly improve energy efficiency. The trains are fitted with the autonomous train integration (ATI) train information and control system, which provides continuous monitoring of all equipment together with a range of inspection and test functions to reduce the workload for train crew and maintenance staff. In the driving cab, the operating console uses a color liquid crystal display (LCD) to display the speedometer and other operational indicators and is designed for visibility and ease-of-use by the driver.

3 Traffic Management System for Kuko and Hakozaki Lines of Fukuoka City Subway

The traffic management system for the Kuko and Hakozaki Lines of the Fukuoka City Subway commenced operation in October 2014.

The system completely replaced the aging existing system, including the central computer in the central control room, man-machine interface, control staff training system, and scheduling support system. As the primary system managing the operation of trains on the Kuko and Hakozaki Lines, it is intended to improve passenger service and traffic management productivity by automating various operations. It also performs monitoring and control of train operation and associated equipment, with a high degree of interoperability with other related systems. The Kuko and Hakozaki Lines have a through service with the Chikuhui Line of the JR Kyushu Railway Company via Meinohama Station, with trains also utilizing the Meinohama Depot. They also connect



3 Traffic displays and control desks for traffic management system of Fukuoka City Subway

with the Kaizuka Line of Nishi-Nippon Railroad Co., Ltd. at Kaizuka Station.

In the future, Hitachi intends to work with its customers to provide a safer and more comfortable subway system that serves as a major artery in the political, economic, and transportation hub of the Kyushu region, supporting the region's largest population.

4 Overnight Work System for Tokyo Metropolitan Bureau of Transportation

The overnight work system supplied to Tokyo Metropolitan Bureau of Transportation improves coordination of maintenance, inspection, construction, and maintenance vehicle driving tasks on the work sections on the four Toei subway lines (65 sections on

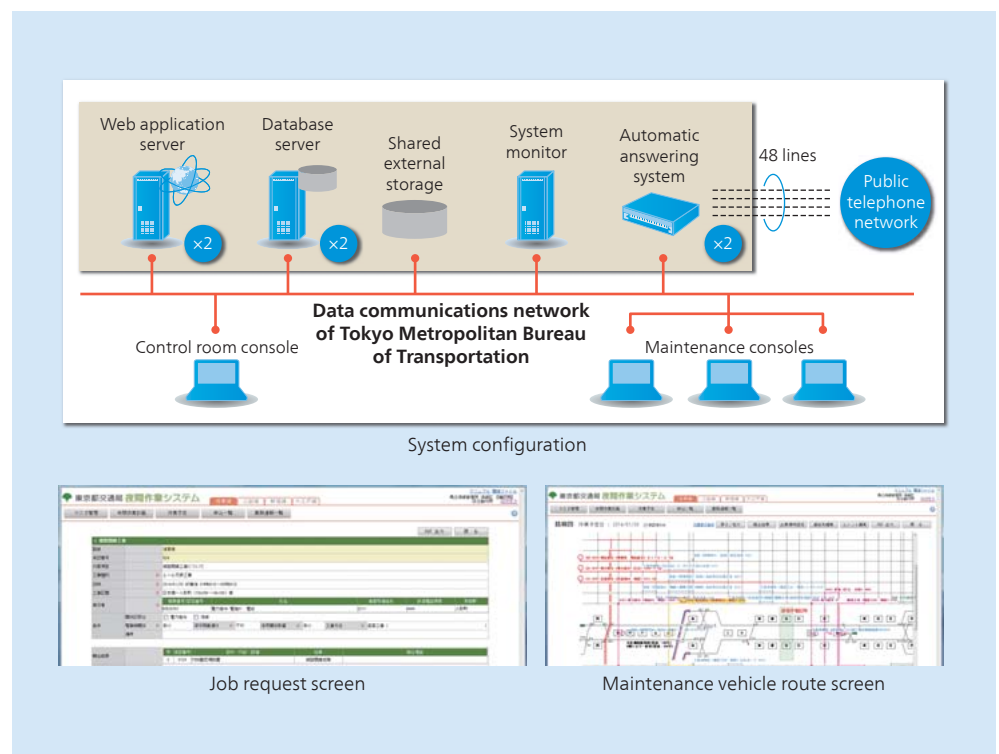

4 Block diagram and example screens from overnight work system for Tokyo Metropolitan Bureau of Transportation

the Asakusa Line, Mita Line, Shinjuku Line, and Oedo Line, including maintenance sections and the control center) and ensures that on-site work is performed safely and efficiently.

The versatility of the system has been improved by providing the ability for all tasks such as job entry and requests and approvals to be entered via a web browser from existing devices. It also uses work-use personal handyphone system (PHS) devices to update work progress in the system, thereby reducing the reporting workload and ensuring timely work management. It also improves the convenience of work start times through interoperation with the traffic management system at the control center.

In the future, Hitachi intends to satisfy a variety of needs by seeking to improve the safety and convenience of overnight work, including through connections to other systems and improvements to usability.



6 Control consoles of ATOS system for District 2 after upgrade

5 Information Display System for East Japan Railway Company Yokohama Line and Nambu Line

The increasing sophistication of devices such as flat panel displays and processors resulting from progress in information and communication technology (ICT) in recent years has led to growing use of LCDs for displaying information to passengers on commuter trains.

Hitachi has been developing passenger information displays with a highly reliable system architecture that use the autonomous decentralized concept developed in the field of traffic management, and that are based on the concept of user-oriented experience design. They present information in a form that the diverse range of people who use commuter trains find easy to read and interpret, and present a wide range of timely information in an interesting way. By using open system interfaces and software-based functions, they are also designed for lower lifecycle costs by providing a total system encompassing both on- and off-train components that can avoid obsolescence and grow over time.

The new system is now in operation, having been progressively rolled out during FY2014, first to the Yokohama Line and later to the Nambu Line of East Japan Railway Company.

6 Upgrades to District 2 Railway Lines of ATOS (Yamanote Line and Keihin-Tohoku/Negishi Line)

In September 2014, upgrades to the District 2 railway lines of the Autonomous Decentralized Transport Operation Control System (ATOS) for the Tokyo region were installed for the central systems of the Yamanote Line and Keihin-Tohoku/Negishi Line.

To satisfy recent customer demands for faster recovery from timetable disruption and more sophisticated information and control, the project included the addition of an operation coordination function to improve passenger services and greater provision of information for related activities.

The operation coordination function for improving passenger services included in the upgrades to the District 2 railway lines is based on the use of computational logic (constraint logic) to model train operation included in the District 1 railway line (Chuo Main Line) and achieves more reliable operations by controlling the timing of delays and departures at each station so they are more uniform. To provide more information for related activity, the system improves the accuracy of activity on subsequent sections of line by collating information about the locations of trains, not only on the sections of line being controlled, but also on other connected sections of line.

As with the District 1 railway line, the switchover to the new system proceeded smoothly. Hitachi intends to continue contributing to safe and reliable railway operations, including during the rollout to additional lines.



5 Passenger information displays used on East Japan Railway Company Yokohama Line and Nambu Line

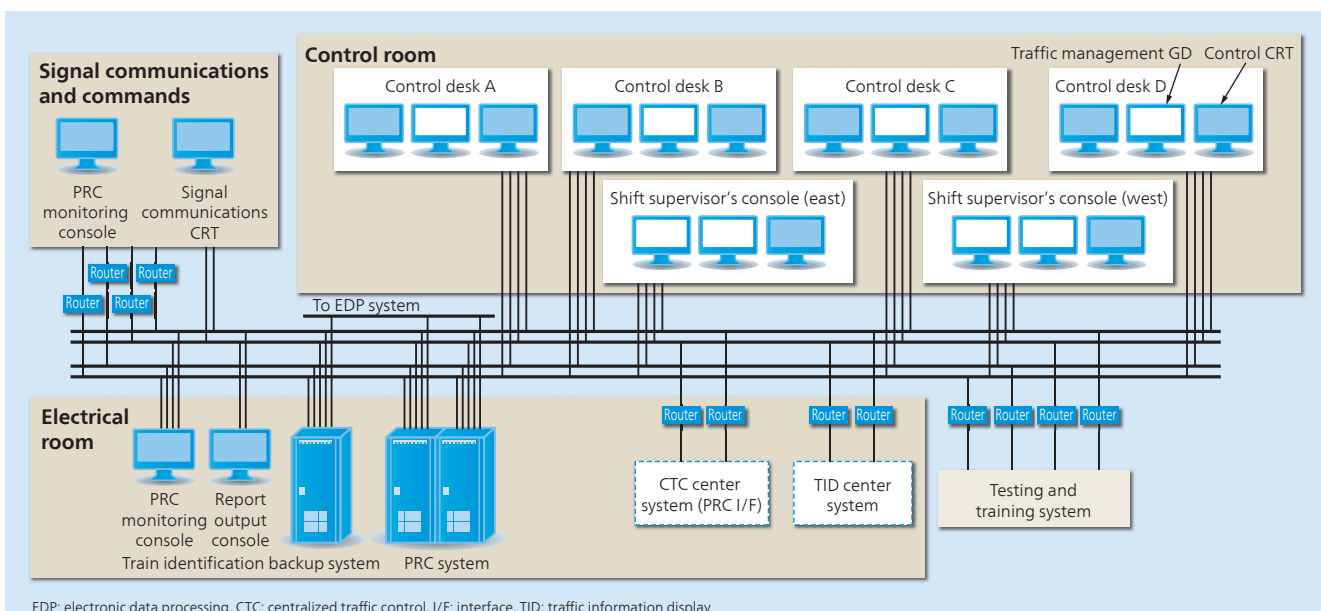

7 Block diagram of traffic management system for Tokaido Line of Central Japan Railway Company

7 Tokaido Line PRC System for Nagoya Control Center of Central Japan Railway Company

The programmed route control (PRC) system for the Tokaido Line of Central Japan Railway Company is a centralized traffic management system that performs monitoring and control of railway traffic on the Tokaido Main Line (Nagoya section).

The new system replaces the existing system. To improve reliability, it includes a train identification backup system to augment the PRC system that performs automatic route control (which has a dual configuration). The backup system ensures that train monitoring and control can continue to function even if both of the PRC systems go down. To improve the efficiency of traffic management, the operation consoles used by the control staff are fitted with traffic management graphic displays (GDs) that display train schedules in numeric format and control cathode ray tubes (CRTs) that display train statuses and allow remote manual control of station routes. The training functions provided by the testing and training system have been enhanced by the addition of a function for recreating past situations from operational records and a scenario function that can be used to run exercises that simulate timetable disruptions.

The system commenced operation in October 2014. Hitachi intends to contribute to further progress in railway systems by utilizing the technologies and functions developed for this system in future upgrades of the traffic management system for the Nagoya region.

8 Functional Upgrade of Tokyo Region Equipment Command System (Control System)

The Tokyo region equipment command system of the East Japan Railway Company was installed in 1995 to improve the efficiency of command and control activities by automating the monitoring and control of power supply, power system, substation, and other facilities used for railway operation in a region encompassing

Tokyo city and eight surrounding prefectures. Since a hardware replacement and development project in 2011 in response to the aging of control center systems, Hitachi has undertaken further development covering functional coordination with ATOS and integration with power distribution supervision aimed at extending the system's functions and strengthening command activities.

In addition to setting and clearing signal inhibits that automatically shut off traction power (power supply), the functional coordination with ATOS consists of automating and simplifying the approval procedures for controlling the turning on and off of traction power by switching from a manual procedure between control staff to one that works by interoperation between systems to ensure that the first and last few trains of the day routinely run on time. This improves safety and dependability, with the associated functions commencing operation in November 2013.

The integration of power distribution supervision into the equipment command system involves connecting station power supply equipment to a data network and was done to cope with the expansion in electrical distribution systems and monitored stations associated with the expansion of the lifestyle services business. This has resulted in an integrated system that provides centralized management from the power plant to station power supplies. The upgrade commenced operation in December 2013.



8 Tokyo region equipment command system (control system)

Public Sector Systems



1 Monitoring and control system for Sorami Sludge Recycle Center of Nagoya City Waterworks & Sewerage Bureau



2 Central control room of monitoring and control system at the Water Supply Management Center of Niihama City Waterworks Bureau

1 Monitoring and Control System for Sorami Sludge Recycle Center of Nagoya City Waterworks & Sewerage Bureau

The sludge produced by Nagoya City's sewage treatment centers is collected together and processed at three sites: in Yamazaki, the Shibata Sludge Processing Plant, and the Sorami Sludge Recycle Center.

The Sorami Sludge Recycle Center was constructed between FY2008 and FY2013, and started processing sludge in October 2013. It processes an average of 5,000 m³/day. The sludge is first concentrated and dried and then completely incinerated.

The system supplied by Hitachi is intended to perform centralized monitoring and control of the concentration, drying, and incineration equipment. It has the following main functions.

- (1) Client-server configuration with dual servers to improve reliability
- (2) Dual configuration for controllers and control local area network (LAN) to improve reliability
- (3) Transmits signals through Internet protocol (IP) communications with a communications controller at the Hojin Water Treatment Center, which takes the plant's sludge return flow water, and performs realtime monitoring of important signals between the two plants. The communications controller also has a dual configuration to ensure reliability.

(Commencement of operation: October 2013)

2 Monitoring and Control System for Water Supply Management Center of Niihama City Waterworks Bureau

The monitoring and control system supplied to the Water Supply Management Center of Niihama City Waterworks Bureau performs centralized management of information from the water

distribution system that consists of 22 water sources located around the city, nine pumping or relay stations, nine distribution reservoirs, and 21 water quality and flow monitoring stations installed at the outer edges of the distribution network. The system was reconfigured to provide reliable and economic operation of the water infrastructure and deal with challenges to the efficiency of maintenance work. To achieve this, the new system includes a demand prediction function, operational functions for pumps and distribution reservoirs, and functions for maintenance that utilize mobile devices such as smartphones or tablets.

The main features of the system are as follows.

- (1) Simulations of pump and distribution reservoir operation plans can be calculated using control parameters from currently operating pump control panels.
- (2) The ability to receive notification of equipment faults via e-mail and display graphics showing equipment status and message screens on a mobile device means that infrastructure managers can determine the status of the water infrastructure quickly, regardless of time or place.

(Commencement of operation: April 2014)

3 Monitoring and Control System for Kamiaoki Water Treatment Plant of Kawaguchi City Water Service Bureau

The Kamiaoki Water Treatment Plant of the Kawaguchi City Water Service Bureau commenced operation in 1952. It has a capacity of 50,200 m³ of water per day, which is drawn from the prefecture and from its own wells.

The monitoring and control system performs remote monitoring of water quality and distribution at the Kamiaoki Water Treatment Plant, Kamine Water Treatment Plant, Shingo Water Treatment Plant, Yokozone Water Treatment Plant, Hatogaya

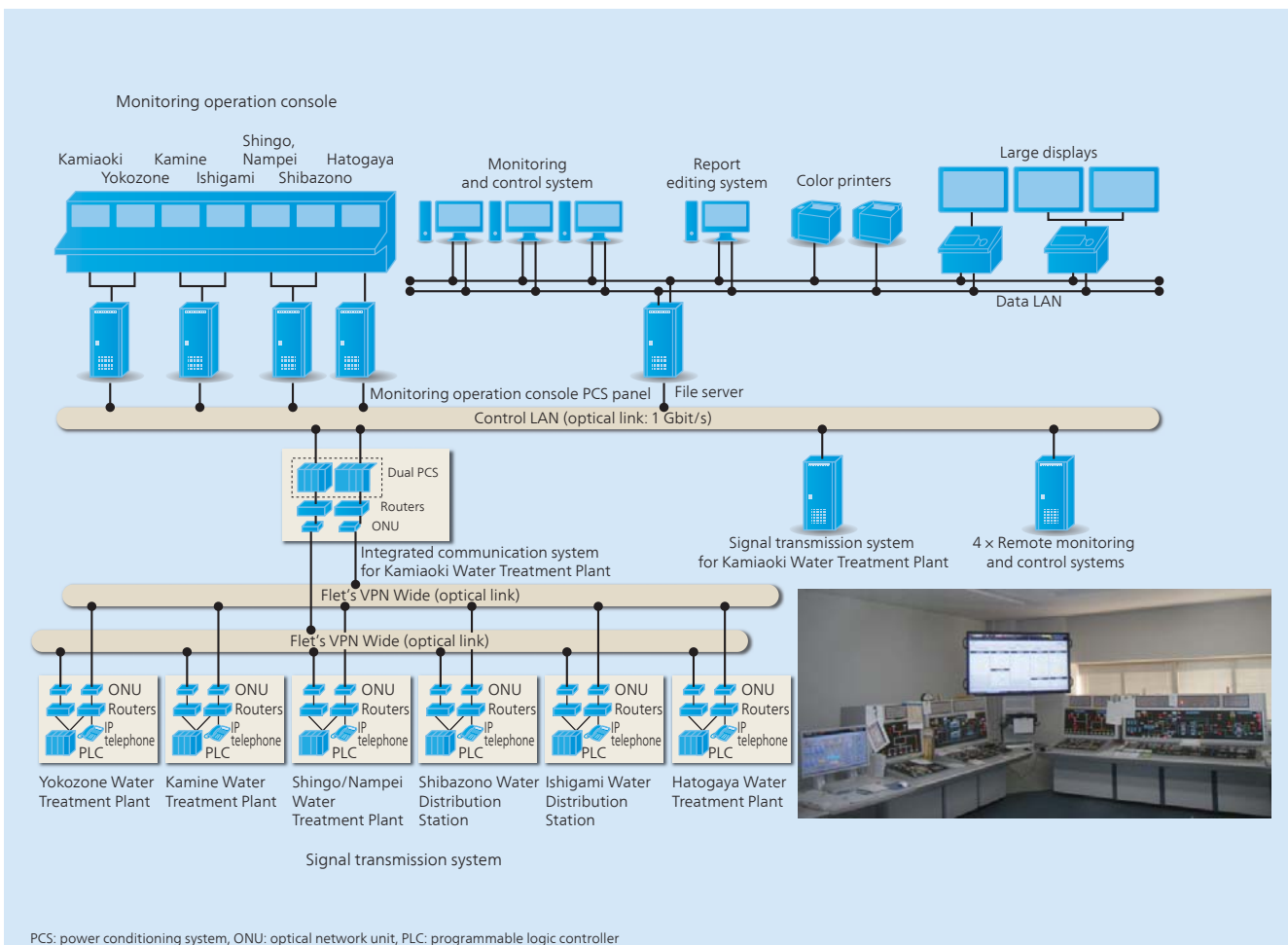

PCS: power conditioning system, ONU: optical network unit, PLC: programmable logic controller

3 Monitoring and control system for Kamiaki Water Treatment Plant of Kawaguchi City Water Service Bureau

Water Treatment Plant, Ishigami Water Distribution Station, Shibazono Water Distribution Station, and Nampei Water Distribution Station. The system has a client-server configuration with remote monitoring cables that were upgraded to a dual optical digital line.

The main features of the system are as follows.

- (1) Dual optical communication system that combines IPLINK modules*1 with Flet's*2 VPN Wide*2,*3 to deal with indirect lightning strikes and provides redundancy in the communication link.
- (2) Minimizes the impact of router failures by using IP telephony with private phone books.

*1 Data transmission modules for IP communications

*2 See "Trademarks" on page 146.

*3 A best-effort service that provides simple private networks between subscribers to the Flet's Hikari Next*3, B Flet's*2, Flet's ADSL*2, and Flet's ISDN*2 services of Nippon Telegraph and Telephone East Corporation and Nippon Telegraph and Telephone West Corporation

rapid filtration, stored in a reservoir, and then supplied via pumps to three cities and one industrial complex.

The central monitoring and control system performs centralized monitoring and control using three monitoring and control operation desks and two large displays. It commenced operation in October 2014.

The main features of the system are as follows.

- (1) High-volume and high-speed communications is achieved by connecting the controllers directly to the 1 gigabit control LAN.
- (2) All of the operation desks used in the past that have built-in mini-graphics panels have been replaced with liquid crystal

4 Central Monitoring and Control System for Hinumagawa River Water Purification Plant of the Ibaraki Prefectural Public Enterprise Bureau

The Hinumagawa River Water Purification Plant of the Central District Waterworks Office of the Ibaraki Prefectural Public Enterprise Bureau has the capacity to treat 24,000 m³ of water per day. Water is drawn from the Hinumagawa River, which is sourced from the Iida Dam, treated using high speed sedimentation and



4 Central monitoring and control system for Hinumagawa River Water Purification Plant of the Ibaraki Prefectural Public Enterprise Bureau

display (LCD) monitors. Dual configurations are used for the water intake, pumping, and chemical treatment equipment controllers in particular, and LCDs are fitted in the controller panels to allow monitoring and operation to be performed from the electrical room as well.

(3) Controllers and modems are used to connect to the central monitoring and control system at the prefecture's Central District Waterworks Office (at the Mito Water Treatment Plant). This was done to enable monitoring and operation to continue to be performed from the Central District Waterworks Office after the system upgrade.

5 Remote Monitoring and Control System for Koriyama Monitoring Center in Sendai City

The storm water and sewerage pumping stations in the Sendai City wastewater system are divided into separate northern and southern sectors, with centralized monitoring and control performed from the Rokuchonome Monitoring Center. With the aim of spreading the risk in the event of a disaster, Hitachi has installed a monitoring and control system for the southern pumping stations at the Koriyama Monitoring Center that incorporates a system for centralized management of the pumping stations in both the northern and southern sectors.

The two monitoring centers are linked by broadband Ethernet. In addition to being able to perform centralized monitoring and control from the Rokuchonome Monitoring Center, as in the past, the new system also allows the same monitoring and control to be performed from the Koriyama Monitoring Center. Reliability has also been improved by using dual communication systems that connect to both the Rokuchonome and Koriyama monitoring

centers for three pumping stations that serve as important external facilities. Ease of use has also been improved and additional functions provided for the web system used to share information with sewage system facilities such as the Minami-Gamo sewage treatment center and city office by installing the new platform system for web services.

6 Advanced, Energy-efficient Sewage Treatment Control System

Hitachi, Ltd. and Ibaraki Prefecture are working with the National Institute for Land and Infrastructure Management to “demonstrate efficient nitrification control with information and communications technology (ICT),” one of the objectives of the FY2014 “Breakthrough by Dynamic Approach in Sewage High Technology Project” (B-DASH project) of the Ministry of Land, Infrastructure, Transport and Tourism, the aim of which is to achieve energy-efficient water treatment and a high level of effluent water quality. The work involves modifying some of the treatment systems at the Kasumigaura Sewage Treatment Plant (with a treatment capacity of approximately 6,500 m³/day) to trial control techniques and collect plant operation data for assessment.

This demonstration will achieve both water quality and energy-efficiency using sensors and control technology as the information and communication technology. Ammonia sensors located midway through and upstream of the aerobic tank play an important role in the work. The system incorporates model-based feed-forward (FF) and feedback (FB) control techniques, functions for visualizing the treatment characteristics, and the automatic updating of control parameters. These are used to

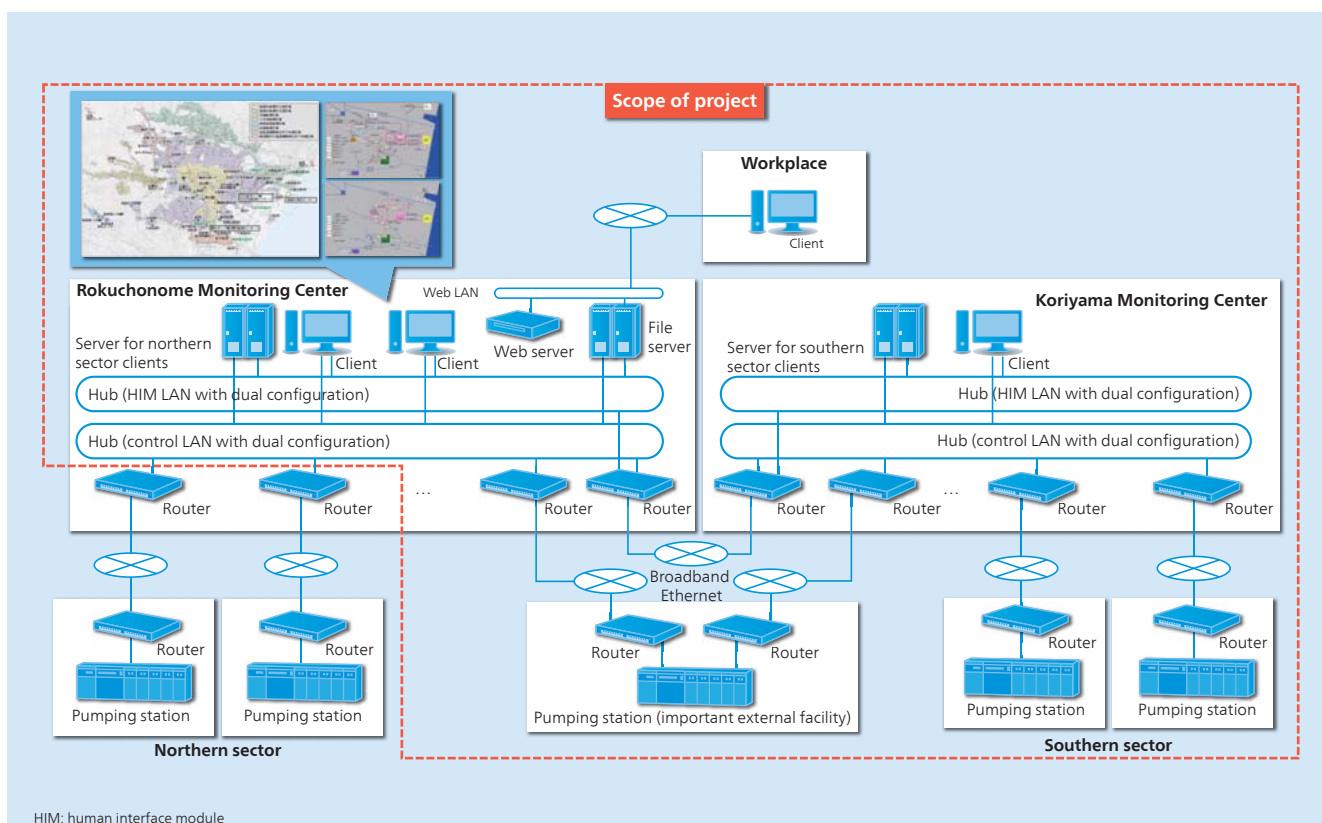

5 Block diagram of remote monitoring and control system for Koriyama Monitoring Center in Sendai City

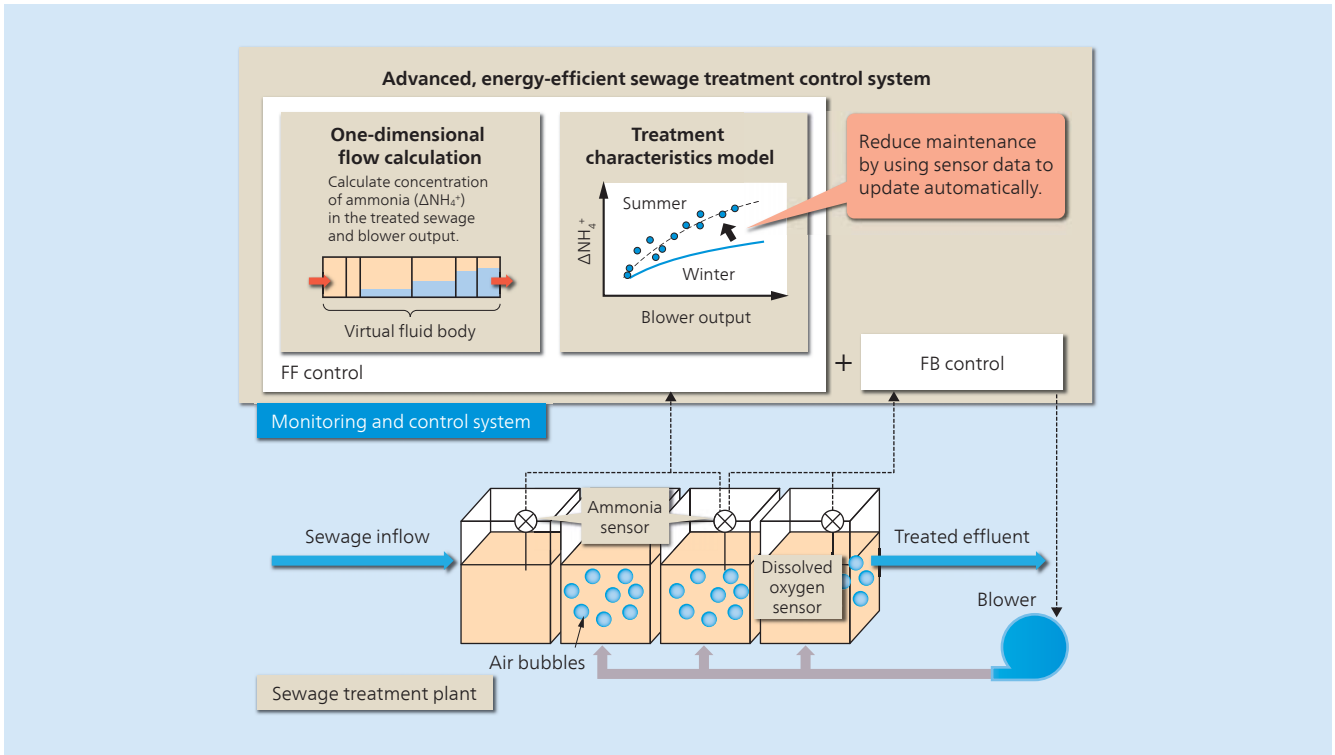

6 Advanced, energy-efficient sewage treatment control system

control ammonia levels in the treated sewage and cut power costs by reducing blower use.

7 Anomaly Prediction and Recovery Support Technology for Water Infrastructure

Anomalies due to age or other factors in the equipment and machinery used in the water infrastructure such as water and sewage treatment plants have been a cause of significant losses for both the public and industry. The challenge of preventing this is to detect potential anomalies pre-emptively and to deal with them before they become a problem.

In response to this challenge, Hitachi is developing technology

to support anomaly prediction and recovery based on operating data from equipment and machinery. This consists of two techniques. The first technique is to use statistics to display variations from normal conditions in the form of a warning level. The second is a semantic network technique that can identify the location of the root cause of the variation from a flowchart of the plant and output recovery instructions.

Used together, these techniques make it possible to act quickly and to prevent equipment and machinery anomalies pre-emptively. This minimizes not only anomalies in the monitored equipment and machinery, but also adverse flow-on effects to other processes.

The technology is very versatile and Hitachi plans to deploy it on outside facilities in the future.

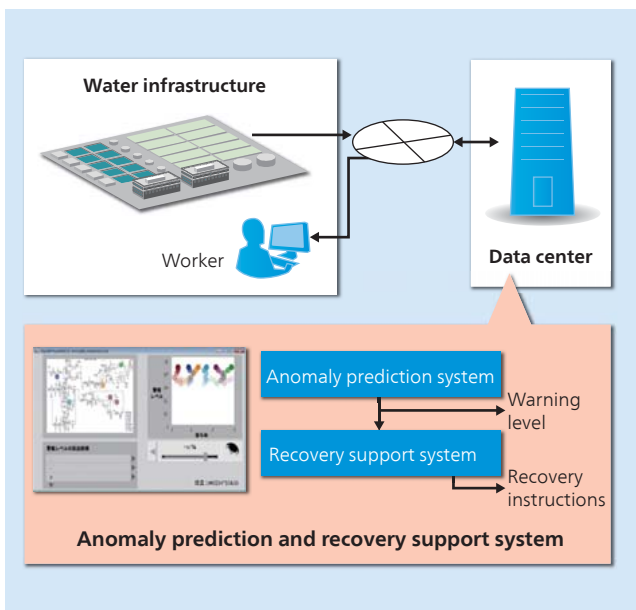

7 Block diagram of anomaly prediction and recovery support system

8 Traffic Conditions Display Panel System for Miyagi Prefectural Police Headquarters

Having suffered considerable damage in the Great East Japan Earthquake, the Miyagi Prefectural Police Headquarters commenced operation of a new traffic conditions display panel system in April 2014.

The aim of the system is to ensure safe and trouble-free road traffic by displaying and monitoring the status of traffic signals and information display boards, as well as traffic congestion based on traffic information and video from industrial television (ITV) and other sources. The display panel consists of 40 (five rows × eight columns) 70-inch digital light processing (DLP) projectors that can display images in windows overlaid on a traffic conditions map, where the window images can be selected from among 32 channels of traffic monitoring cameras or television images and eight channels of personal computer (PC) screens, and displayed in any size or location.



8 Traffic conditions display panel system for Miyagi Prefectural Police Headquarters

Given the growing concern from the public about disaster prevention and mitigation, Hitachi intends to continue enhancing systems that contribute to providing safety and security, not only during disasters or other emergencies, but also under normal conditions.

9 Large Display for Communication and Command System for Miyagi Prefectural Police Headquarters

The Miyagi Prefectural Police Headquarters commenced operation of a new communication and command system in March 2014.

The system is intended to improve communication and command activities by overlaying a map of the entire Miyagi Prefecture with windows showing emergency (110) call information and police car locations on a 72-inch multi-display unit (12 screens). It also includes a sub-system that assists decision making by providing video feeds to six 70-inch LCDs and ten 19-inch

monitors on the dispatcher desks in the central control room.

The multi-display unit uses DLP projectors with the latest light-emitting diode (LED) light sources. The average lifetime of the LED light sources is approximately 80,000 hours*, more than six times that of the high-pressure mercury lamps used in the past. This reduces the frequency of routine replacement of consumables. Also, the video control and operation software supports the efficient operation of the large display unit with functions such as selecting the screen display pattern or videos to display, centralized control of audio, and turning equipment on or off.

In the future, Hitachi intends to continue working on longer equipment life and higher reliability, these being important factors for the systems that underpin the social infrastructure.

* The average lifetime is defined as the mean time for LED brightness to fall to half of its initial level.



9 Large display for communication and command system for Miyagi Prefectural Police Headquarters

Security Technologies for Social Infrastructure

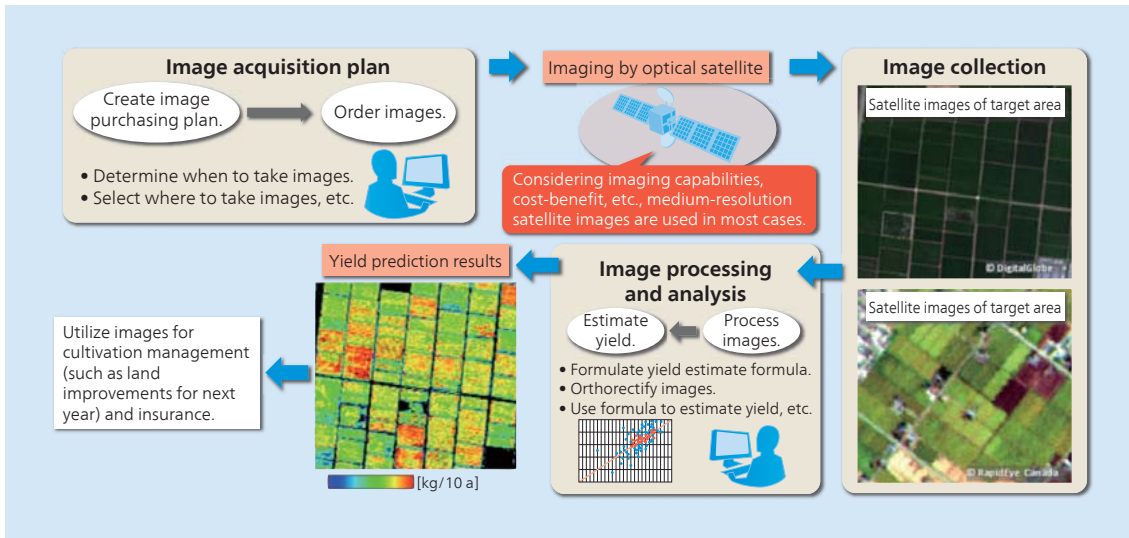

1 Rice paddy harvest assessments made using satellite images

1 Satellite Imaging Solution for Agriculture

The world's population is forecast to grow from 6.5 billion now to reach nine billion in 2050, prompting predictions of imbalances in the supply and demand for food on a global scale.

The monitoring of large areas of a nation's land, including farmland, can be performed using images taken by Earth-imaging satellites 500 to 700 km above the Earth. Applying its precise analysis techniques to these satellite images, Hitachi believes it can provide information for correcting imbalances in supply and demand for food by assessing rice paddy harvests and using these assessments as a basis for undertaking yield improvements.

In the future, Hitachi intends to continue contributing to the resolution of global-scale food supply problems through basic information delivery services that provide satellite images and rice paddy harvest assessments made by sophisticated processing and analysis of those images.

issues like the ability to withstand disaster, responsiveness, and security into account. To achieve this, Hitachi adopted the following three measures.

- (1) Use of a redundant system configuration (using two separate data centers) to increase the ability to withstand disaster
- (2) Low-overhead display format to allow for heavy traffic loads during a disaster
- (3) Secure communication of information to be published on the portal site and robust security protections against cyber-attack

Through the operation of this highly reliable portal site, Hitachi is contributing to the reliable distribution of disaster information and the strengthening of regional disaster prevention capabilities.

With growing uncertainty about disaster risks, Hitachi intends in the future to continue strengthening its disaster prevention and mitigation solutions that ensure public safety and peace of mind by providing two-way communication between central government and the local government agencies that handle on-site disaster response.

2 Cabinet Office Disaster Information Portal

The disaster information portal of Japan's Cabinet Office retrieves disaster information that needs to be released from an Integrated Disaster Management Information System and makes it available to regional agencies and other organizations involved in disaster prevention, and also to the general public.

Ensuring both the confidentiality of the Integrated Disaster Management Information System and the convenience of the disaster information portal requires a system design that takes

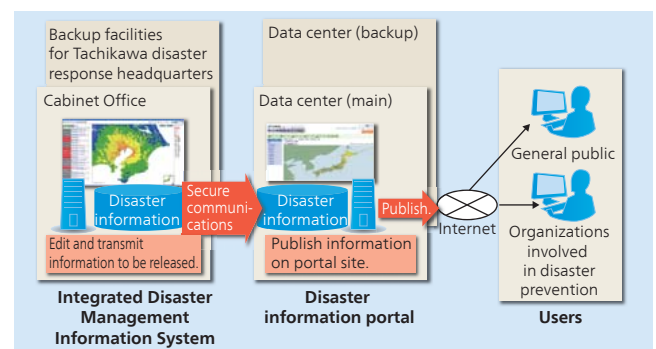

2 Overview of Cabinet Office disaster information portal

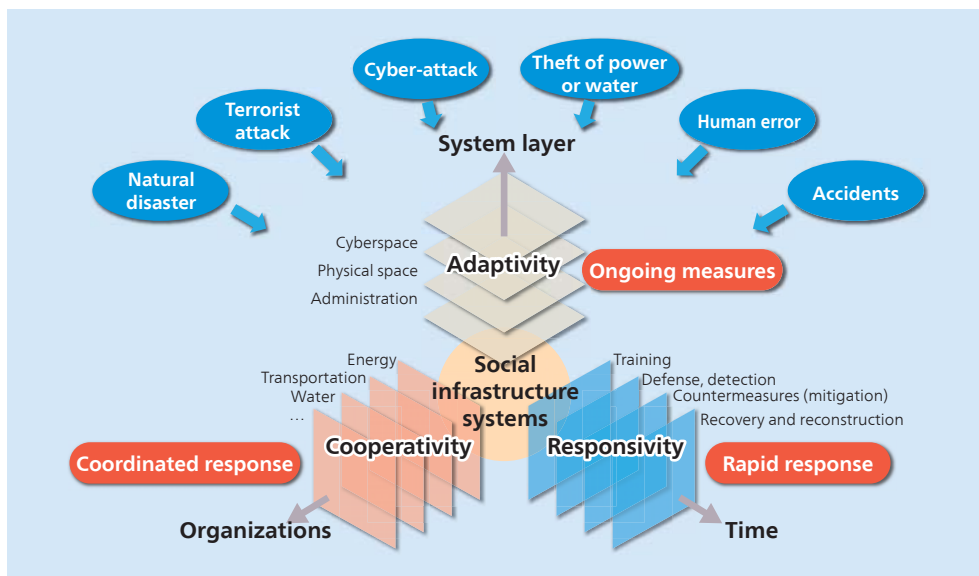

3 Application of Hitachi’s concept to crisis management security

3 Crisis Management Security Solutions

The tendency when natural disasters, accidents, terrorism, or other crises have occurred in recent years has been for the impact to be exacerbated by unanticipated consequences and flow-on damage. When dealing with a crisis, obtaining a rapid awareness of the situation and ensuring different organizations are able to coordinate their activities smoothly become matters of urgency. An international standard (ISO 22320) has been formulated for this purpose. Hitachi already supplies a wide range of security solutions that support activities such as situation awareness and incident response.

Hitachi has defined the concept for social infrastructure security based on “adaptivity,” “responsivity,” and “cooperativity” in recognition of the need to augment information across different organizations and to rapidly obtain situation awareness and allocate responsibilities in order to mount a rapid response to unanticipated consequences and flow-on damage, and is working on expanding crisis management security solutions in accordance with ISO 22320. In particular, it is possible to minimize capital and operating costs while also seeking to enhance interoperation between organizations by adopting a framework that provides for sharing of information between systems and flexible additions and extensions to the sequence of monitoring, decision-making, and action.

Hitachi intends to strengthen crisis management throughout society by supplying security solutions for all types of social infrastructure systems, including facilities used to stage national events and critical infrastructure.

4 Geospatial Information Platform System

Fast-growing regions such as the nations of Asia require reliable geospatial information in order to provide a platform for national activity.

The geospatial information platform systems supplied by Hitachi, especially their core map production systems, are able to manage map quality, including the elimination of inconsistencies, while still representing the complex geographic features characteristic of Asia, and are used for the efficient production of extensive national maps. This enables the creation of maps that are suitable for uses such as infrastructure planning and regional government activities, and facilitates the updating of maps to keep them up to date with changes in a region over time.

Hitachi is also participating in standardization activities to facilitate the sharing and utilization of geospatial information across multiple government agencies and the private sector. This includes co-chairing a working group on moving features data exchange formats for the sharing of location information between mobile phones, vehicles, and other systems for the Open Geospatial Consortium (OGC), an international standards body for geospatial information, and also serving as an advisor to the board of the Japan National Committee for ISO/TC 211.

In the future, Hitachi intends to continue contributing to the development of different regions by proposing comprehensive geospatial information platform systems, including satellite imagery and surveying techniques.

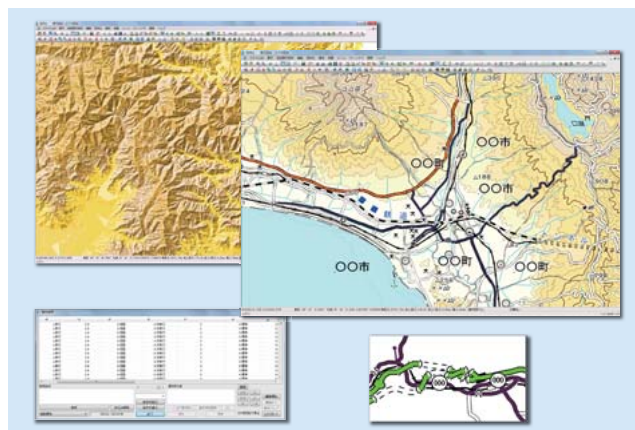

4 Map production system for national-level geospatial information platforms

Elevators



2,200-kVA control panel

330-kW PM motor winch

1 Drive unit for 20-m/s elevator and artist's impression of completed CTF Finance Centre

1 World's Fastest Elevator (20 m/s)

Hitachi will supply the world's fastest elevator*, with a speed of 20 m/s, to the CTF Finance Centre, which is due to be completed in Guangzhou, China in 2016. For the new elevator, Hitachi developed a 330-kW permanent magnet (PM) motor winch, the largest class used in an elevator; a 2,200-kVA control system consisting of two inverters connected in parallel, each of which has four insulated-gate bipolar transistors (IGBTs), also connected in parallel; a brake with heat-resistant braking material; a high-strength rope approximately 30% stronger than the rope used for ultra-high-speed elevators in the past; and a four-stage telescopic shock-absorber with an installed size that is approximately 40% smaller than the previous buffer design.

Hitachi has conducted research at the G1TOWER, a 213-m high elevator test tower, aimed at ensuring low levels of vibration and noise when elevator cars are traveling at very high speeds. This has included research on a streamlined cover for reducing wind noise at very high speeds, and an active guide unit that

significantly reduces elevator car vibration due to rail bending.

Hitachi intends to utilize the technologies for drive, control, safety, and comfort that it has built up through this development work to continue supplying elevators that are reliable, comfortable, and convenient.

* As of April 21, 2014. Based on research by Hitachi, Ltd.

2 New Model of Standard Elevator

Hitachi released a new model of its standard elevator in May 2014. This is the first new product released since Hitachi, Ltd. undertook measures to strengthen the company in April 2014 and transferred its Japanese elevator business to Hitachi Building Systems Co., Ltd. The main features of the new elevator are as follows.

(1) A 5% improvement in energy efficiency compared to the previous model;* achieved by reducing the power consumption of the electrical and electronic components, including the winch brake and ceiling light-emitting diode (LED) lights.

(2) New design features and functions that take advantage of the capabilities of LED lighting. These include the addition of wall line lighting to provide a greater sense of spaciousness and high quality by giving the impression of light entering the elevator car through a window, and an automatic lighting tone adjustment function that switches between a lively white light during the day and an elegant artificial lighting feel during the night.

(3) Improved reliability achieved by incorporating programmable electronic safety technology into the elevator's safety systems to reduce the use of other components such as mechanical devices (switches, etc.), relays, and contactors.

(Hitachi Building Systems Co., Ltd.)

* Compared to the model released in 2012 during normal operation (based on research by Hitachi Building Systems Co., Ltd.). Actual performance will depend on operating conditions.

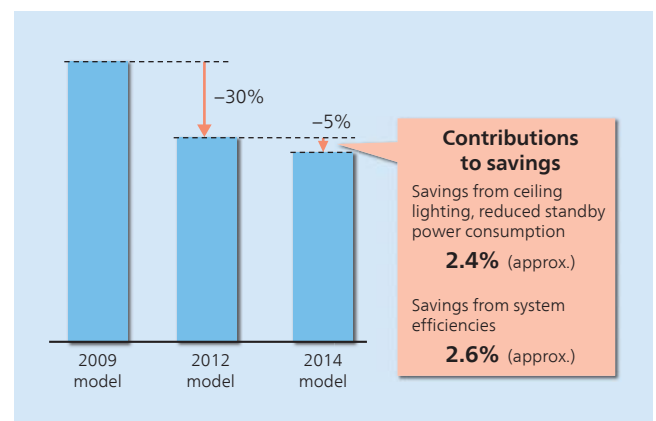

2 Energy efficiency comparison with previous model

3 Expanded Maintenance Service for New Model of Standard Elevator

Coinciding with the release of the 2014 model of its standard elevator, Hitachi has expanded the range of options it offers in its building care network maintenance service that was first introduced for the 2012 model. This service allows building managers to modify certain elevator settings from a personal computer (PC) via the Internet. These include such control settings as which floor the elevator waits on when not in use, and information display settings for the liquid crystal display (LCD) indicators in the elevator cars.

The main functions are as follows.

- (1) Control settings for six additional functions, including whether to provide express service or stop at every floor.
- (2) New digital signage function for the elevator car display information, including news and weather.
- (3) Greater convenience, including the ability to perform operations from a smartphone and a service for specifying settings on the customer's behalf.

The new model also features a reduction to an average of three minutes (previously six minutes) in the response time required to respond remotely to people who are stuck in an elevator. This was made possible by the adoption of Internet protocol (IP) networking for remote monitoring, enabling high-speed communications and simultaneous transmission of voice and data.

In the future, Hitachi intends to keep pace with changes in the needs of building managers and other users so that it can continue developing new products with enhanced competitiveness.

(Hitachi Building Systems Co., Ltd.)

New functions for in-car information display service



Weather
Local weather reports (Forecast supplied by Japan Meteorological Corporation)
The weather forecast is displayed continuously using icons.



News
Regular updates of the latest news, displayed as a single screen for quick reading. (News supplied by Kyodo News)

New functions for elevator control service (the two functions described in the article)

Express service

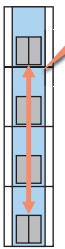

No stops on intermediate floors

Elevator travels directly to the intended floor regardless of requests from other floors.

All-floors service

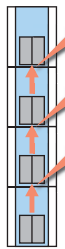

Stop

Stops at all floors regardless of whether anyone has requested the elevator.

Four other new functions for elevator control service

Overhead flooding evacuation (changes default floor to top floor)	When enabled, service continues with the top floor now being the default floor.
Exclusive service to specific floors	Modifies elevator button operation to disable requests for designated floors.
Operates in conjunction with emergency earthquake notifications.	If an Earthquake Early Warning is received from the Japan Meteorological Agency, it stops any in-service elevator at the nearest floor.
Earthquake drill operation	Used to practice elevator operation and control as if during an earthquake.

3 New options offered by the building care network service

4 India's Fastest Elevators for High-rise Residential Building in Mumbai

Hitachi is going to supply 14 elevators, including four ultra-high-speed models, to Nathani Heights, a 72-story high-rise residential building project in central Mumbai on India's west coast that is scheduled to be completed in 2016. The 72-story residence will be one of the tallest residential buildings in Mumbai. In addition to the residential units, the luxury complex will also include retail stores, a fully equipped gym, a swimming pool, a mini theater, and other amenities.

Hitachi will supply 14 elevators in total, including four ultra-high-speed models with a speed of 360 m/min, making them India's fastest*. The ultra-high-speed elevators feature an earthquake emergency system that enables elevators to evacuate rapidly to the nearest floor when its sensors detect that the building is swaying as the result of an earthquake. Another feature enables users to pre-select their destination floor before the car arrives so that elevators can be allocated to users based on their destination floor. By combining passengers going to the same destination floors, this system alleviates congestion and increases overall vertical transport efficiency in the building. Hitachi is also going to supply seven high-speed elevators, including a glass elevator with a speed of 240 m/min that will also be the fastest of its type in India*.

* As of May 2014, based on research by Hitachi, Ltd.



4 Artist's impression of Nathani Heights

Industrial Equipment and Systems

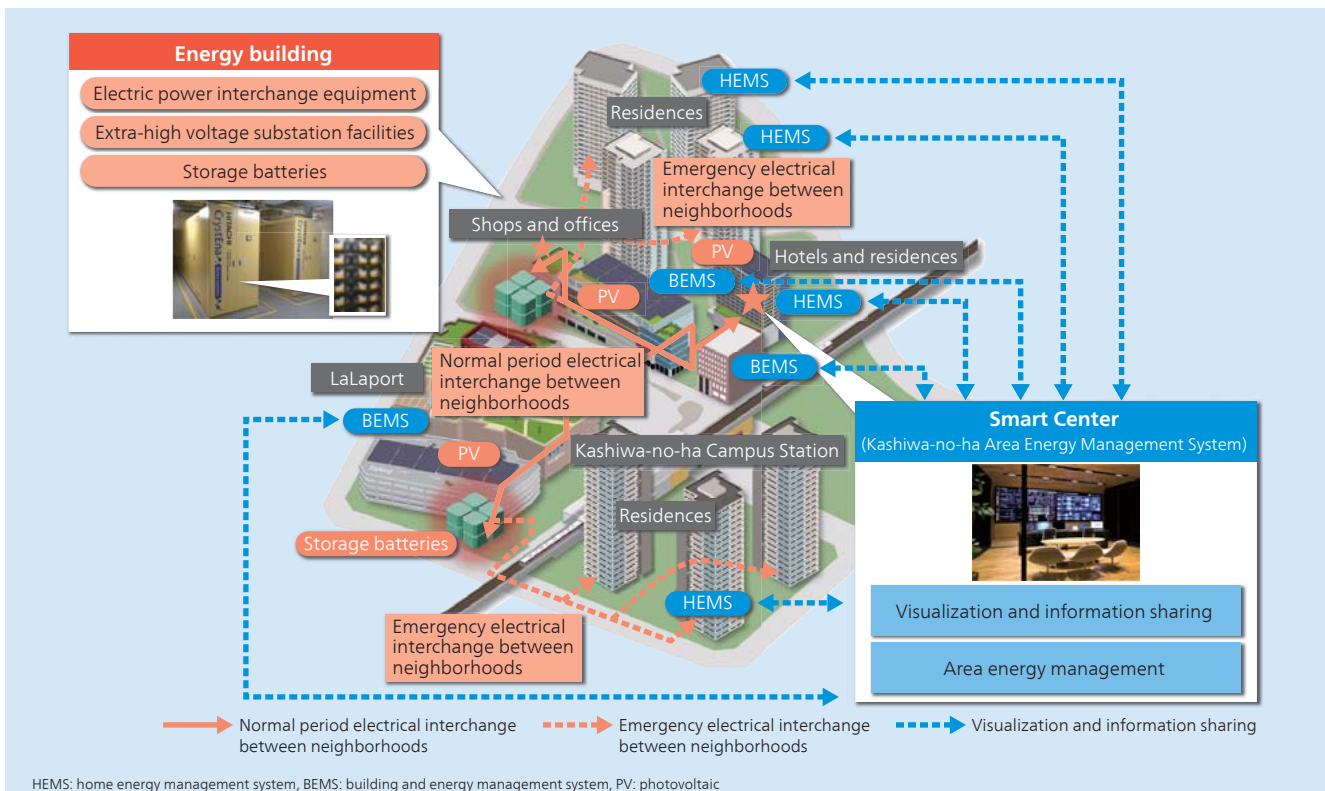

1 Management of energy across multiple neighborhoods by the Kashiwa-no-ha Area Energy Management System

1 Area Energy Management System for Kashiwa-no-ha Smart City

The Kashiwa-no-ha Area Energy Management System commenced full-scale operation in July 2014, coinciding with the opening of Kashiwa-no-ha Smart City being developed by Mitsui Fudosan Co., Ltd.

The system consists of a private power grid that incorporates renewable energy, Japan's largest lithium-ion storage batteries, a system for sharing electric power between neighborhoods, and an information system that performs centralized supply and demand management for residences, offices, and shopping centers throughout the city. It seeks to reduce power bills and carbon dioxide (CO₂) emissions through measures that include providing specific advice on how to save energy based on actual usage, and peak-cutting power sharing arrangements between facilities that experience peak demand at different times.

Reductions in peak demand at shopping centers were successfully achieved during the city's first year through the sharing of green energy. The project also succeeded in involving residents in reducing energy use by issuing power savings requests (based on demand predictions) for an incentive scheme in which users earn regional points. It is creating new civic value by sharing the

essential energy supplies required by consumers and businesses across the city in the event of a power outage caused by a disaster, for example.

2 Integrated Energy and Equipment Management Service

Against a background that includes a series of major disasters and a shortage of specialist managers due to the falling population, consumers have come to recognize the potential of cloud services that offer centralized management of energy and equipment operation information at a low price for a variety of different facilities, such as offices, factories, and shops.

A feature of the integrated energy and equipment management service is that it provides access rights to Hitachi's "service mall" not only to consumers, but also to retailers, equipment vendors, and others. It eliminates the need for consumers to enter into a separate contract for each equipment vendor's cloud service, and provides equipment vendors with online access to analytical data without the need to set up their own infrastructure. Use of the service mall improves the convenience and operational efficiency of both problem analysis and equipment upgrade planning. The service also offers an energy efficiency guidance function (an

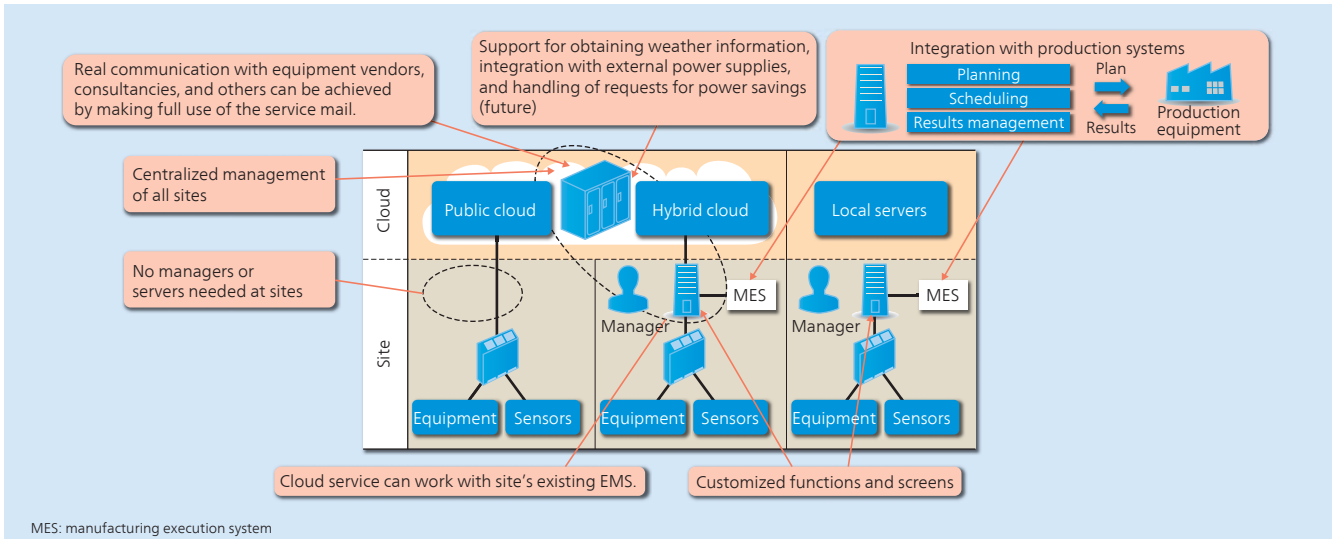

2 Service mall concept

optional service for factories) that works through integration with production planning systems.
(Date of service commencement: February 2015)

3 Use of High-level Compression and Super-resolution Processing in Video Surveillance System

The shift to networked cameras with high image quality and resolution has been accelerated in recent years by the wider use of networks and the adoption of digital video. However, because of the increase in data volume that accompanies higher image quality and resolution, this has also created problems that include the rising cost of providing additional hard disk drive (HDD) capacity and the increased load on the networks used to transmit this data.

Now, Hitachi has developed a video surveillance system that reduces data volume by performing a high degree of compression

in the camera and uses software-based super-resolution processing*1 to display video with high image quality. This reduces data volume to between one-third and one-quarter the original size*2, thereby helping reducing HDD costs and network bandwidth usage.

It is anticipated that future systems will become increasingly networked and that demand will grow for large cloud-based systems that provide centralized management of video data at a data center. To satisfy this demand, Hitachi intends to develop products that incorporate compression, image processing, and other advanced techniques and supply a wide variety of security solutions, including remote surveillance services that utilize the cloud.

(Hitachi Industry & Control Solutions, Ltd.)

*1 A signal processing technique for producing images with higher resolution than the transmitted image.

*2 When compared to images stored in super extended video graphics array (SXVGA) resolution (1280 × 960 pixels).

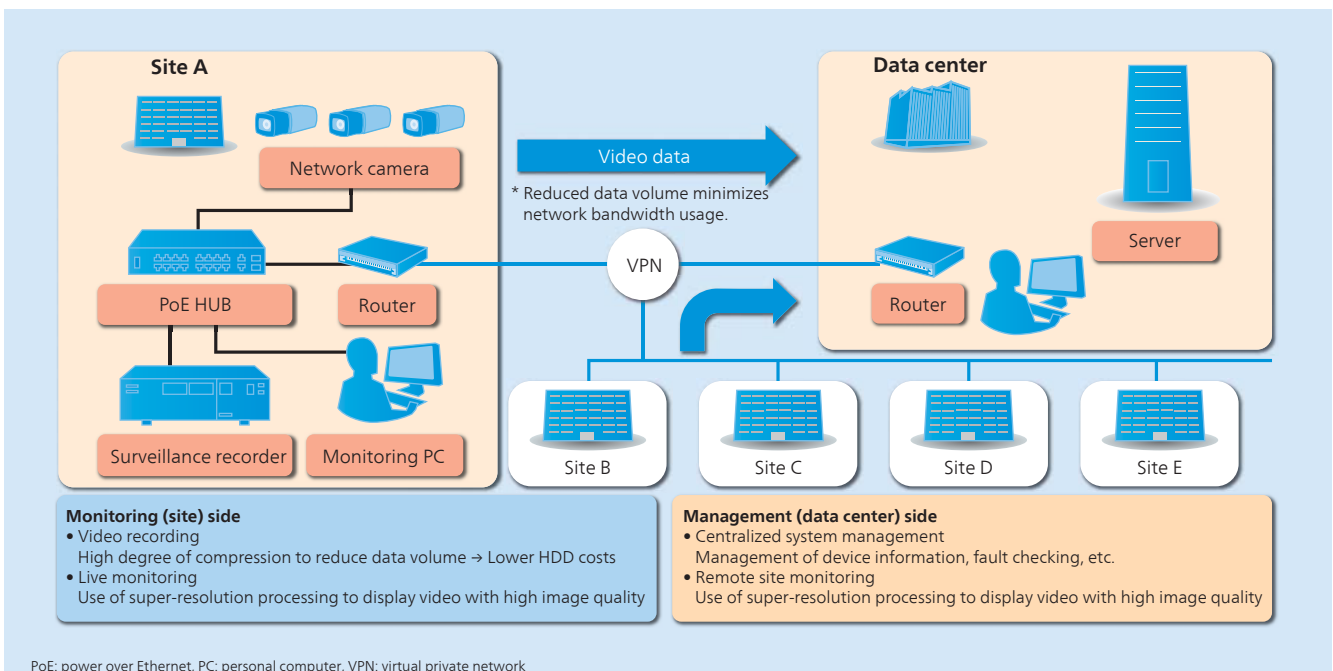

3 Block diagram of video surveillance system



4 5-MW-PMG generator

4 5-MW Wind Turbine Generator

A 5-MW downwind offshore wind power generation demonstration system is currently being built at a waterfront site in Kamisu City in Ibaraki Prefecture to meet demand for larger offshore wind power generation systems. To make the offshore wind turbine smaller and lighter, and require less maintenance, the system uses a permanent magnet generator (PMG).

The main features are as follows.

- (1) Uses a PMG to reduce weight.
- (2) Uses water cooling for a more compact design.
- (3) Has fewer permanent magnets due to the use of finite element method (FEM) analysis for optimal generator design.
- (4) Reduces maintenance requirements by using permanent magnets (PMs) to eliminate the need for an exciter with rotor slip rings and brushes.

In addition to the use in future offshore wind turbine design of operating data from the 5-MW offshore wind turbine and the 2-MW model developed previously, Hitachi also intends to continue working to commercialize offshore wind turbines to make them larger and to contribute to the global environment by conducting trials of the 5-MW downwind offshore wind power generator.

5 25-MW Synchronous Motor

The oil and gas market has continued to grow in recent years, with growing demand for natural gas, which is cleaner than other fossil fuels. While standard practice in the past has been to use gas turbines to power the compressors used in oil and gas plants, there has been a progressive shift toward electric drives along with heightened requirements for energy efficiency and CO₂ emissions reduction.

While synchronous motors and induction motors are the two main forms of compressor drives, there is a tendency to use synchronous motors in the 10-MW or higher range because of their power factor advantages. Accordingly, Hitachi has been



5 25-MW synchronous motor

developing a compact and lightweight synchronous motor in the 25-MW class. By adding synchronous motors to its existing series of induction motors, Hitachi is expanding its product range and the scope of its business.

6 Application of Modular Power Conversion Unit for a UPS

Hitachi has developed a 100-kVA uninterruptible power system (UPS) that incorporates a modular power conversion unit, which features power modules that are cooled on both sides to achieve excellent cooling performance.

The main features are as follows.

- (1) The UPS unit has been made smaller by using an all-in-one



6 100-kVA UPS

design that includes a bypass circuit and maintenance bypass circuit. The result is an about 30% smaller installation footprint and an about 30% smaller volume than the existing Hitachi UPS with the same capacity. It also has a panel design that features the same installation footprint regardless of whether external cabling is routed from above or below.

(2) The new UPS adopts the same concept as previous Hitachi models by allowing units to be connected in parallel, enabling system configurations that satisfy user requirements such as reliability, ease of maintenance, expandability, and future upgrades. The new UPS has also been designed to allow it to be retrofitted into an existing system.

(3) The rectifier/inverter/chopper circuits at the heart of the UPS have a modular design made up of standard units, thereby reducing the number of spare parts required.

(4) The UPS has a high output, with a rated power factor under load of 0.95 for an input voltage of 200 V, and 1.0 for an input voltage of 210 V, making it compatible with the increasingly common practice of operating with high-load power factors.

In the future, Hitachi intends to utilize the technology developed for this model in 200-kVA and 300-kVA UPSs.

Specifically, this involves supplying systems for detecting and forcibly disconnecting unauthorized PCs, one-way bridges, and controllers with ISASecure Embedded Device Security Assurance (EDSA) Certification* in the form of attack defense solutions that protect control systems from security incidents. Other intrusion detection solutions supplied by Hitachi include systems for detecting and forcibly disconnecting unauthorized PCs, systems for the early detection of malware intrusions, and a security damage analysis service.

Utilizing these solutions, Hitachi provides engineering support for control security implementation that complies with standards such as IEC 62443 and also considers “responsivity” for effective implementation of the plan, do, check, and act (PDCA) cycle required by control systems, “adaptivity” for working rapidly through the observe, orient, decide, and act (OODA) loop, and integration and “cooperativity” between multiple systems.

* A security certification program for embedded systems in control equipment (controllers, safety controllers for safe instrumentation systems, and programmable controllers) developed by the International Society of Automation (ISA) Security Compliance Institute (ISCI)

7 Cyber Security Solutions for Control Systems

Hitachi supplies products and services for maintaining security and preventing cyber-attacks on the key industrial systems that underpin the social infrastructure in the form of total solutions.

8 Obtaining ISASecure EDSA Certification for a Controller

Hitachi is working to enhance the security of control equipment components and to comply with international standards by offering attack defense solutions that protect control systems from security incidents. One of Hitachi’s main controller products, the plant controller, was certified in July 2014 under the ISASecure

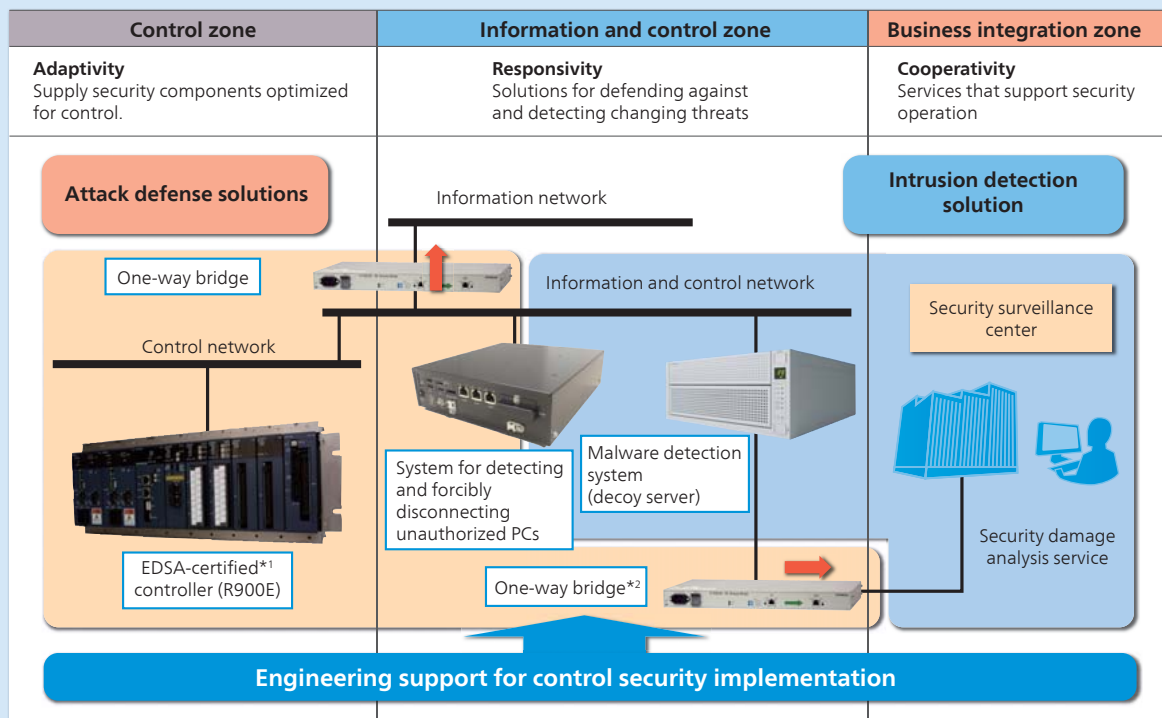

*1 ISASecure EDSA 2010.1. Level 1 certification number: CSSC-C00002

*2 Configuration of equipment used to notify of detections differs depending on notification methods and where they are sent. The diagram shows the overall configuration. Additional peripheral devices are required when using a one-way bridge.



8 Plant controller (top) and EDSA certificate (bottom)

EDSA international standard for security certification in the control equipment field.

ISASecure EDSA Certification for control equipment verifies whether it satisfies the requirements for each of a number of predefined security levels*. The Hitachi plant controller obtained certification because it satisfies the applicable requirements.

In the future, Hitachi intends to contribute to building the secure control systems essential to social and industrial infrastructure through the development and supply of control equipment components that comply with security requirements.

* EDSA Certification defines requirements to be assessed at a number of security levels, covering communication robustness testing (CRT), functional security assessment (FSA), and software development security assessment (SDSA).

9 One-way Bridge

Hitachi has developed a one-way bridge that improves control system security.

The bridge protects mission-critical systems by transmitting required information from the system to an external destination while also physically blocking unauthorized access and malware intrusions. This makes it possible to provide services that utilize data from power plant control systems or railway traffic



9 One-way bridge

management systems, for example, by enabling the safe delivery of the latest detailed information from the system.

The one-way bridge has an IN port for receiving packets from the mission-critical system and an OUT port for forwarding the packets to an external destination. The bridge is able to forward outbound packets only one way, while still maintaining the ability to establish connections using Ethernet's widely used autonegotiation procedure by using a physical layer control function developed by Hitachi (patent pending) to provide the connection through each port.

Following installation on a nuclear power plant system, Hitachi intends to deploy the technology in a wider range of industries in the future, including transportation systems.

10 System for Detecting and Forcibly Disconnecting Unauthorized PCs HJ-7725

The importance of security is growing for control systems just as it is for information systems. To provide security products for control systems, Hitachi has developed the HJ-7725, a ruggedized system for detecting and forcibly disconnecting unauthorized PCs that incorporates the network monitor software for this purpose.

The main features are as follows.

- (1) A fully enclosed design with no slits or other openings to improve tolerance against dust.
- (2) Easier maintenance achieved by locating all connectors and status lights on the front panel.
- (3) No fan or HDD, thereby eliminating parts that require periodic replacement.

The HJ-7725 enables the function to scan for unauthorized PC connections and forcibly disconnect them even in the sort of environments found in industrial plants. In the future, Hitachi plans to further extend the range of environments in which the system can be used, including making it smaller and giving it a wider temperature range (-10°C - $+60^{\circ}\text{C}$).



10 HJ-7725 system for detecting and forcibly disconnecting unauthorized PCs



11 HF-W7500 Model 40 industrial computer

11 Industrial Computer HF-W7500 Model 40

Featuring long life and long-term availability, the HF-W series of industrial computers are increasingly being deployed in the information and telecommunications field, including such applications as monitoring and control and in disaster prevention systems. Now, Hitachi has developed the HF-W7500 Model 40 as part of its top-end HF-W7500 series of models. The Model 40 features approximately double the performance* of the previous model and has entered service in applications such as instrumentation and semiconductor inspection equipment.

The HF-W7500 Model 40 is designed for performance, with a high-performance central processing unit (CPU) (approximately double the performance of the previous model*) and a maximum 32 Gbyte of error checking and correcting (ECC) memory capacity (also double that of the previous model*). With the same physical dimensions as previous models, it is compatible with existing systems and has continued support for the Peripheral Component Interconnect (PCI) bus. Hitachi intends to expand the scope of applications for the computer even further in the future, offering new interfaces such as Universal Serial Bus (USB) 3.0, a multilingual user interface, and support for overseas standards.

* Compared to the Hitachi HF-W7500 Model 30.

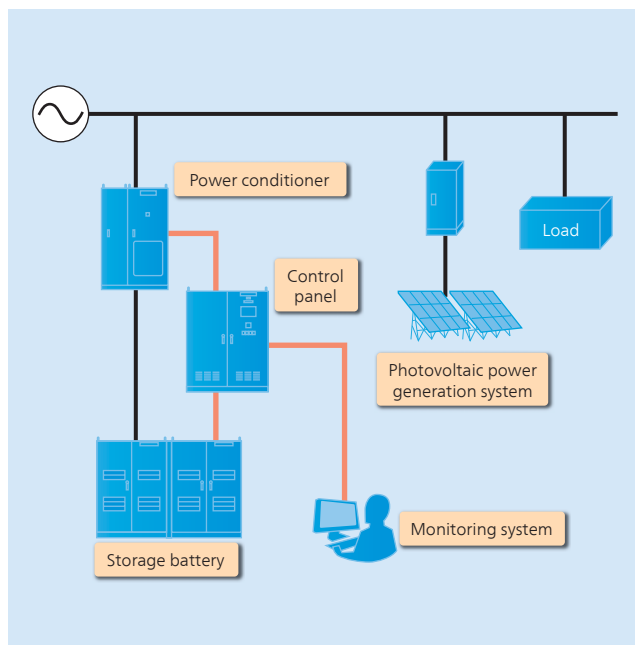

12 Example configuration of an industrial energy storage system

12 Industrial Energy Storage System

Hitachi has added to its range of energy storage systems with the development of a new mid-range model for general industrial use.

In addition to smoothing power use by cutting peaks in demand and ensuring that energy is used effectively by operating in tandem with photovoltaic power generation, the system also plays a role in business continuity planning (BCP) by supplying electric power during power outages. It achieves high reliability by continuously monitoring battery status, and can be configured as required, with a choice of battery types (lithium-ion or lead-acid) and selectable capacity determined by varying the number of connected batteries.

The main benefits of installation are as follows.

- (1) Reduce electricity bills by using nighttime (off-peak) power and avoiding the risk of demand exceeding the contracted level.
- (2) Maintain power to selected loads during a power outage by switching to standalone operation.
- (3) Store excess photovoltaic power during non-emergency conditions, and use generated power to charge batteries during a power outage.

(Hitachi Industrial Equipment Systems Co., Ltd.)

13 Super-high-efficiency Transformer

As part of the shift to Top Runner 2014 transformers that comply with the second round of Top Runner standards under the April 2014 Act on the Rational Use of Energy, with the designation "super-high-efficiency" being used for those transformers that achieve 115% of the Top Runner requirement, Hitachi has fully revamped its range of energy-efficient models and commenced sales under the super high efficiency transformer series brand. In addition to energy efficiency performance, the new models also



13 Oil-filled transformer (top) and molded transformer (bottom)

losses, a super series with significantly reduced losses, and a compact series designed to minimize installation dimensions. The molded transformer range, meanwhile, is divided into the super and compact series.

(Hitachi Industrial Equipment Systems Co., Ltd.)

14 Simple Energy Monitoring System

To facilitate energy savings using an energy management system (EMS), Hitachi power distribution and utility monitoring system supplies data collection software for general-purpose PCs together with multi-circuit units and clamp-on current sensors to provide energy consumers with an economical way of collecting environmental and energy efficiency data.

Hitachi began supplying this simple monitoring system in 2013, providing an easy way to monitor energy use without requiring a PC to be running continuously. The logger collects data at one-minute intervals and regularly saves it on USB memory. The data display software can read the recorded data from the USB memory and use it to produce trend graphs and daily, monthly, or yearly reports, and export it in a standard comma-separated value (CSV) file format. The collation and analysis of data can also be performed easily using macro software specifically designed for this purpose. It is also possible to set up a simple monitoring program that is even easier to use by connecting the logger to the PC via a local area network (LAN) and having the data display software use the file transfer protocol (FTP) to obtain the data without any manual handling of the USB memory.

(Hitachi Industrial Equipment Systems Co., Ltd.)

feature a design that can withstand seismic vibrations to enhance tolerance for earthquakes.

To satisfy a wide range of customer needs, the range of oil-filled transformers is divided into a premium series with extremely low

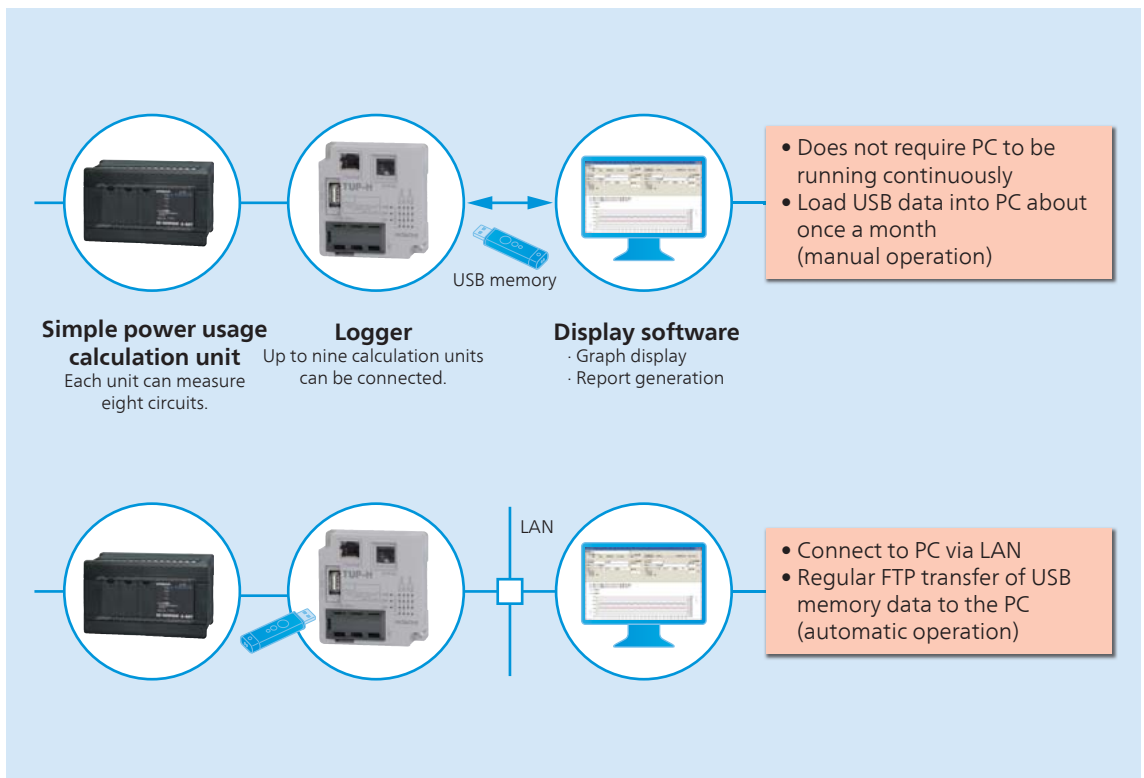

14 Components of a simple energy monitoring system

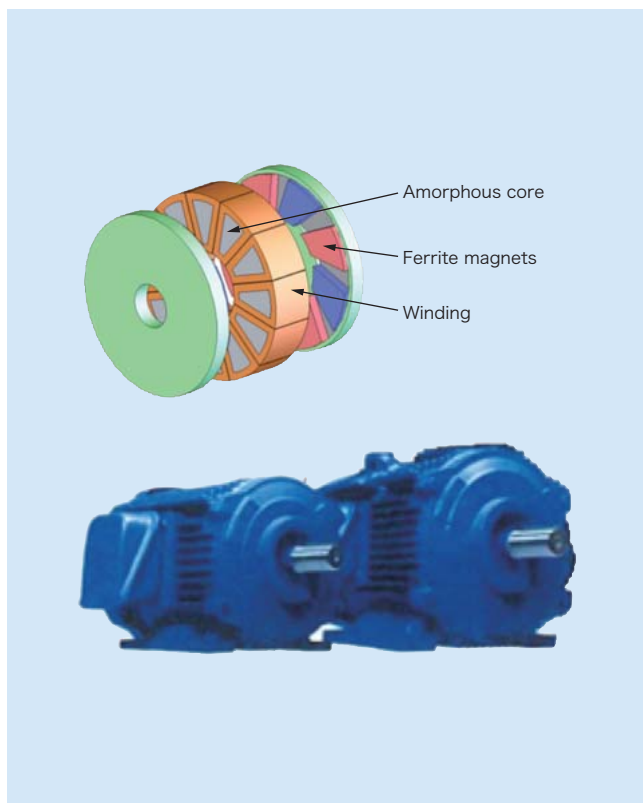

15 Axial gap structure of highly efficient amorphous motor without rare earths (top) and motor bodies (bottom)

15 Highly Efficient Amorphous Motor without Rare Earth Metals

While industrial motors have become more efficient over recent years in response to factors such as the growing international demand for energy efficiency and increasingly stringent motor efficiency rules, the market is demanding even greater energy savings and higher efficiency. In response, Hitachi has developed a range of highly efficient PM electric motors, rated between 3.7 and 11 kW, that use amorphous alloy but not rare earth metals (neodymium and dysprosium).

The motors feature a new core design with a laminated structure made from a low-loss iron-based amorphous alloy, and enhanced manufacturing techniques to facilitate mass production. To achieve high efficiency, Hitachi has also optimized the design of the double-rotor axial gap structure with ferrite magnets. In addition to satisfying the requirements of the IE4 (super premium efficiency) motor efficiency class of the International Electrotechnical Commission (IEC) despite being smaller than a standard induction motor, the motors also reduce the supply risk for rare earths.

(Hitachi Industrial Equipment Systems Co., Ltd.)

16 Inverters for Overseas Markets

Since approximately 60% of inverters manufactured by Hitachi are sold overseas, along with the need to develop technologies that improve basic performance, the inverters also need to satisfy the requirements of diverse overseas markets.



16 NJ600B inverter for overseas markets

The NJ600B inverter for overseas markets incorporates the functions of the current L700 series of export models. All steps from development to production were undertaken by Hitachi Industrial Equipment (Nanjing) Co., Ltd., which is based in China. Along with a product range that extends from 18.5 kW to 355 kW, models that are certified as complying with European and American standards are built on a separate production line to achieve a balance between cost and performance.

Although the inverters have been manufactured for the Chinese domestic market to date, shipments to parts of Southeast Asia will commence in 2015. To satisfy regional requirements for Southeast Asia, the inverters include a sleep mode for shutting down fan or pump operation if the output frequency is too low and can be customized using a simple sequence programming function (EzSQ) available on standalone inverters.

(Hitachi Industrial Equipment Systems Co., Ltd.)

17 New Oil Flooded Screw Compressor

Amid the growing severity of environmental problems such as global warming over recent years, Hitachi has released 22/37-kW oil flooded rotary screw compressors as next-generation products that contribute to the environment and society by saving energy. Based on the same development concepts as the current models, the new models feature greater added value that includes even better energy efficiency.

The main features are as follows.

(1) An improvement of up to 3% over current models in free air delivery is achieved through enhancements that include the



17 New oil flooded rotary screw compressor
(22/37-kW air cooled model)

development of airend with new rotor profile and a new oil supply mechanism.

(2) Upgraded standard specifications to allow the operation up to an ambient temperature of 45°C achieved through enhancements to the cooling system that provide higher unit cooling efficiency, improvement of cooling performance due to the change of the cooler, and the development of a new dryer.

(3) 7.5% lower power consumption*¹ is achieved through new energy-saving control functions which are provided as standard features that include predictive control of terminal pressure.

(4) All models are equipped with color touch panel and a communication board developed by Hitachi. A USB connector is provided for operational data logging and to enable data recognition and setting change from a mobile device via Bluetooth*² dongle. Modbus*² communication is also supported.

(5) Equipped with a motor complied with Top Runner standard (IE3 or more under IEC standard) which enters force in FY2015 as a standard feature.

(Hitachi Industrial Equipment Systems Co., Ltd.)

*1 At 60% load with 0.15-MPa pressure loss to discharge port

*2 See “Trademarks” on page 146.

18 Pump with Built-in PM Motor and Integrated Controller

To meet demand for smaller and more energy-efficient pumps, Hitachi has released a range of pumps with built-in PM motors and integrated controllers (motor capacity: 1.5 kW to 3.7 kW).

The PM motors are more efficient than similar induction motors (IMs). By taking advantage of the smaller size of PM

motors, Hitachi has combined the PM motor and controller in a single unit (the PM motor controller is fitted around the motor). This results in a motor that is the same size as an IM, and Hitachi has developed the new product by fitting it on a general-purpose pump.

The pump incorporates a variety of pump control functions that Hitachi has built up through past experience with water pumps. These include controlling for constant estimated end pressure to achieve energy-efficient operation, a function for alternating between pumps that automatically shuts down pumps when water volume is low and alternates between pumps when restarting, and a function for operating two pumps in parallel for cases when there is not enough water. Hitachi has also provided ways of operating pumps to avoid interruptions to water supply, including switching between pumps such that, if a pump goes out of service due to a fault, a different pump is started instead. Further development is continuing, including the ability to operate with even greater energy efficiency by increasing the available motor capacities up to 7.5 kW.

(Hitachi Industrial Equipment Systems Co., Ltd.)



18 Inline pump (model codes: J LH and J LSH) (top) and centrifugal pump (model code: J DH) (bottom)



19 High-speed hoist rated for 30-t loads

19 High-speed Hoist Rated for 30-t Loads

For rated loads of 10 t or more, the proportion of electrically operated hoists used in overhead cranes and similar machinery is about 40%. Because electric hoists will need to outperform crab cranes if their share of the market is to expand, the major challenge is to increase speed. Also, while electric hoists typically use inverters to provide continuously variable speed drive and reduce the effect of mechanical shock during operation, in the past the regenerative energy produced while lowering a load has been dissipated as heat through a resistor.

Now, Hitachi has developed a high-speed electric hoist with a regenerative converter with the aim of saving energy by feeding regenerative energy back into the power supply. It is anticipated that demand for energy efficiency and higher speeds will continue to grow strongly in the future, not only in the Japanese market, but also internationally.

The main features are as follows.

- (1) Achieves faster speeds and smaller size by using a drive system with two motors and reduction gears.
- (2) Is able to detect when no load is present and operate at twice the normal rated speed.

The new model is a traversing unit rated for lifting loads of 30 t. Hitachi plans to release further models in the series in the future. (Hitachi Industrial Equipment Systems Co., Ltd.)

20 Development of PLC Communications Module Board

Since 1999, Hitachi has released a series of communication modules that support the PROFIBUS* and DeviceNet* open field networks for programmable logic controllers (PLCs). To get the product to market quickly, the models released as a result of the

initial development were based on a separate configuration for each field network. However, this required multiple boards and levels of shared memory and therefore made it difficult to optimize both performance and price.

In recent years, there has been growing demand from both the end users and vendors of control systems to minimize the installation cabling requirements and cut the cost of maintenance, with sensors and actuators increasingly being connected to the network. The use of variable-speed motor control to save energy has also been growing, as has the installation of energy monitoring systems. Responding to demands from major customers that are planning to restructure their operations around globally distributed production sites, Hitachi has established a platform that uses processors with built-in support for industrial field network protocols and that can incorporate a variety of different communication modules at low cost.

The first product to be released, in August 2013, was an EtherCAT* slave unit, followed subsequently by a PROFIBUS/DeviceNet slave unit. The range is also being expanded to include master units for FL-net and DeviceNet. (Hitachi Industrial Equipment Systems Co., Ltd.)

* See "Trademarks" on page 146.

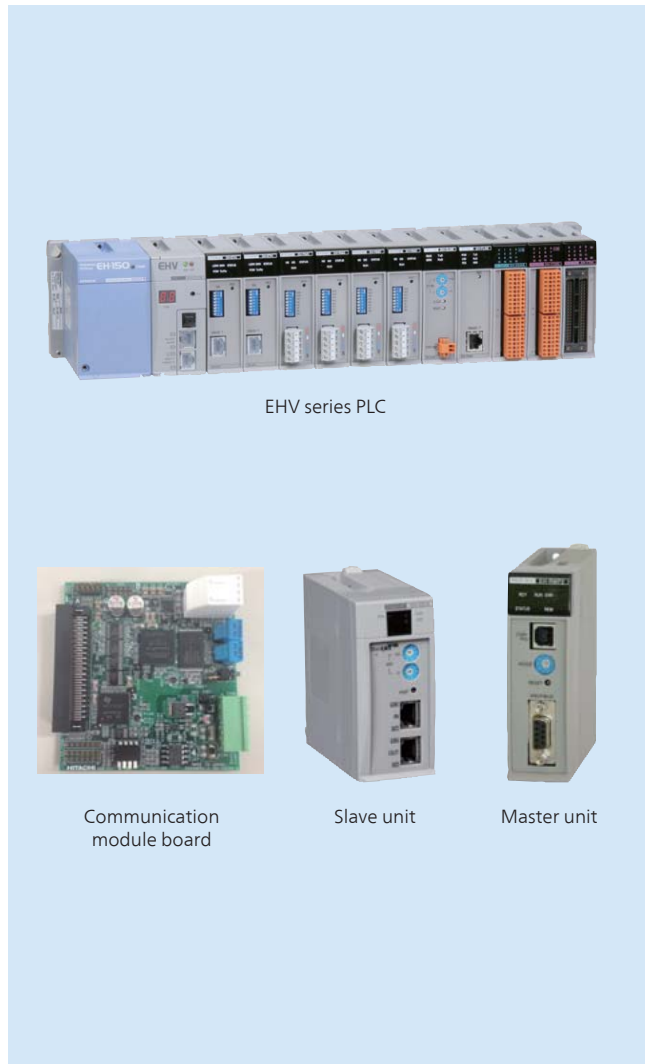

EHV series PLC



Communication module board



Slave unit



Master unit

20 Development of PLC communications module board



21 LTE unit for M2M communications

21 LTE Unit for M2M Communications

Hitachi has released a packet communications unit that uses the Long Term Evolution (LTE) standard for mobile phone networks for machine-to-machine (M2M) communications.

The Internet of things (IoT), meaning the networking of a variety of different devices via the Internet, has started to make its presence felt in the industrial sector, resulting in growing demand for communication devices that support LTE, which is a major new-generation mobile phone network that provides high-speed communications. Because of its high reliability, Hitachi's new M2M communication adapter is used in social infrastructure and other industrial applications, where it is used for M2M communications over the mobile phone network of the KDDI Corporation in Japan.

The main features are as follows.

- (1) Equipped with a built-in LTE communications module that enables communications from any location that is covered by KDDI's LTE mobile phone network.
- (2) Supports a variety of routing protocols, meaning it can be used as a LAN router as well as for LTE wireless communications.
- (3) Has the same high reliability as other products in the CPTrans series, which are used for such applications as social infrastructure monitoring.

The new product can satisfy a wide range of needs, with other features including an RS-232C interface and a business plan with an inclusive communications contract.

(Hitachi Industrial Equipment Systems Co., Ltd.)

22 Three-dimensional Position Sensor

The existing image collecting Hitachi data acquisition system sensor system used to control the movements of materials handling robots used to control the movements of materials handling robots includes a function for using laser range-finders to create a two-dimensional map, and a function for detecting the

robot's position on the map. The aim of the research and development of the new three-dimensional position sensor was to utilize the same principles as two-dimensional position detection to create a three-dimensional map and use it for position detection.

The main features are as follows.

- (1) Like Hitachi positioning system, the three-dimensional map is created from measurements collected by moving the sensor around on a trolley or other vehicle.
- (2) Because it uses laser range-finders, position detection is not influenced by lighting conditions as would happen with a camera.
- (3) The use of two general-purpose two-dimensional laser range-finders reduces the cost compared to using a special-purpose three-dimensional laser sensor.

(Hitachi Industrial Equipment Systems Co., Ltd.)

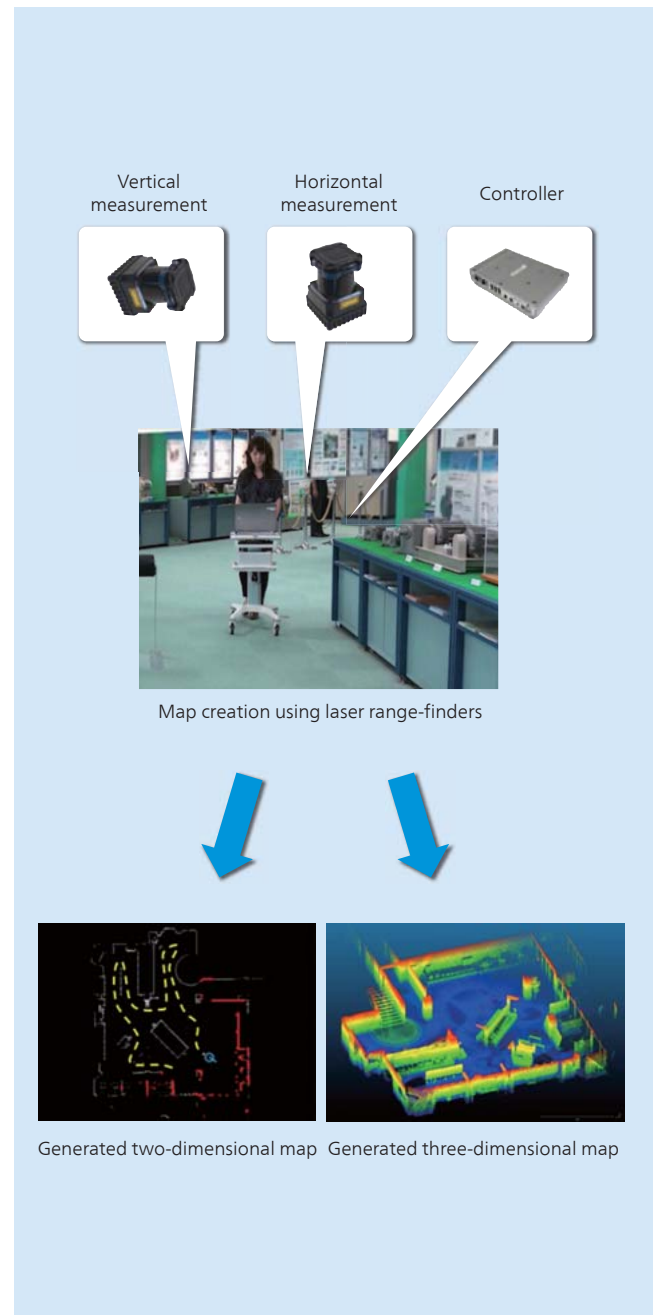

22 Three-dimensional position sensor



RAS-AP560DN1 outdoor unit

23 “Low Ambient Model” series outdoor unit for cool-climate multi-split air conditioning systems for buildings (56.0-kW model)

23 “Low Ambient Model” Series Outdoor Units for Cool-climate Multi-split Air Conditioning Systems for Buildings

Hitachi has updated the product range for its “Low Ambient Model” series of outdoor units for cool-climate multi-split air conditioning systems for buildings, adding 33.5-kW, 40.0-kW, and 50.0-kW models to the existing 22.4-kW, 28.0-kW, 45.0-kW, and 56.0-kW models, extending the range to seven models in total, and also adding seven new upgrade models that are able to reuse existing plumbing.

The main features are as follows.

- (1) Heating capacity increased by approximately 50% over Hitachi’s standard multi-split air conditioner for buildings, meaning that the rated heating capacity (heating capacity for an outdoor temperature of 7°C) can be maintained for outdoor temperatures down to -10°C.
- (2) Improved comfort levels when operating in heating mode thanks to a frost level detection function that reduces the frequency of defrosting by more accurately detecting the presence and level of frosting, and a new defrosting system that can switch between two different defrosting methods (hot gas bypass

defrosting and reverse-cycle defrosting).

- (3) Lower annual power consumption thanks to an improved freezing cycle and better use of freezing cycle control*.

(Hitachi Appliances, Inc.)

* 8% reduction compared to previous 28.0-kW model

24 Hitachi Acquires Certification of Large-scale Water Injection Pump from Saudi Arabian Oil Company

Hitachi has acquired Saudi Arabian Oil Company (Saudi Aramco) certification of its large-scale water injection pump by demonstrating high reliability and availability through successful site trial testing for more than 13,000 hours attained by applying the latest technologies, and in compliance with API 610 as well as Saudi Aramco specifications.

This water injection pump is a large capacity, high pressure, multi-stage pump, driven by an approximately 28,000-kW gas turbine (ISO rating), which delivers a high rated pressure of commingled water (seawater + brine water) at approximately 200 bar (approximately 20 MPa), and reaches deep into the oil reservoir to enhance oil production as well as to maintain oil reservoir pressure.

The main features of the Hitachi water injection pump are as follows.

- (1) Ensures high reliability using a corrosion-resistant, high-intensity duplex stainless steel material for handling commingled water.
- (2) Achieves better life cycle cost (LCC) with high-precision computational fluid dynamics (CFD) technology.
- (3) Ensures stable operation that results in very low vibration levels, using precise rotor dynamics verification.
- (4) Adoption of cutting-edge technology for shaft seals and bearings achieves compactness and longer lifetime of auxiliary equipment.

Hitachi understands the importance of providing pumps of various specifications, optimizing customer satisfaction, since each water injection pump has its own requirements that will depend on the properties of the pumped liquid and characteristics of the crude oil reservoir.

Based on this achievement, Hitachi will continue to contribute

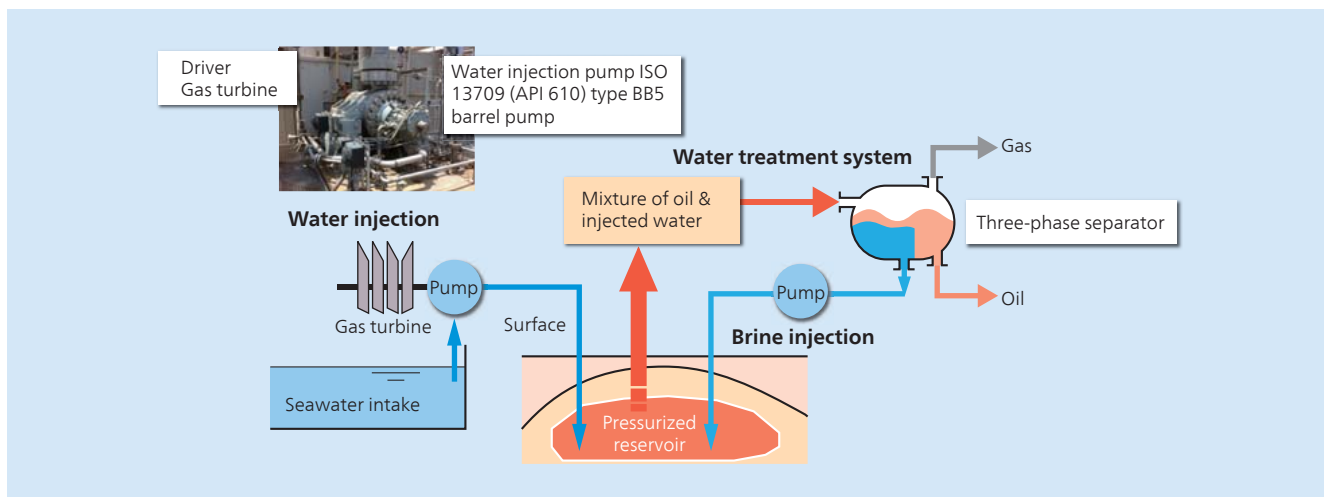

24 Water injection system and operating condition of large-scale water injection pump (left above)

to a worldwide stable energy supply by providing reliable and efficient water injection pumps to the oil and gas industry.

25 Large-capacity Pumps for the Yellow River Water Conveyance Project

Hitachi manufactured and delivered eight main pump units for Wanjiazhai as part of the Yellow River Water Conveyance Project, one of the large-scale projects on which the Chinese government is focusing for industrializing the northwest districts of China. The pumps intake water from Wanjiazhai, a town located in the watershed of the Yellow River, and provides water to major cities in northwestern China through 400 km of water channels.

The main features of the pumps are as follows.

- (1) Adopting a proprietary flow analysis method developed by Hitachi utilizing know-how gained from CFD and visualization of the internal current, the large-scale pumps have an output of 6,500 kW/12,000 kW, achieving high efficiency exceeding the customer's requirements and contributing to the reduction of life cycle costs.
- (2) With an optimized coating utilizing CFD erosion prediction, the pumps can withstand the particularly abrasive characteristics of the Yellow River and operate for a long time.
- (3) High reliability is ensured by weld construction impellers that adopt steel plate vanes.
- (4) Serviceability is ensured by the application of large split-type shaft seals.

The pumps have already been completely installed/commissioned, and provide a stable supply of water.

Hitachi intends to continue contributing to the development of water infrastructure through active participation in future water conveyance projects around the Yellow River based on this significant experience.

Item	High-lift pump specifications	Low-lift pump specifications
Type	Vertical-shaft, single-suction volute pump	Vertical-shaft, single-suction volute pump
Diameter	φ2,000 mm	φ2,000 mm
Capacity	6.45 m ³ /s	6.45 m ³ /s
Design head	140 m	76 m
Rotation speed	600 min ⁻¹	500 min ⁻¹
Efficiency	≥91%	≥91%
Electrical output	12,000 kW	6,500 kW
Quantity	6 units	2 units

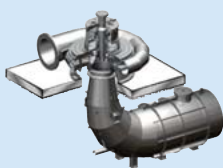

25 Specifications (top) and exterior (bottom) of high-capacity pump for the large-scale Yellow River Water Conveyance Project (China)



26 Compressor rotor with 13 impeller stages

26 Development of a 13-stage Centrifugal Compressor

In 2013 Hitachi received an order for a hydrogen recycle gas compressor for a hydro treatment plant in Russia, with final contract delivery in 2014. The hydro treatment plant is used for removing sulfur, nitrogen, oxygen and metal from oil using a special catalyst with hydrogen. Usually for this type of API617 compressor in a hydrogen recycle service there are six or seven impeller stages in the casing to satisfy the required pressure rise in the machine. However, in this project, the hydrogen content is higher than other plants of similar design, it is 2.03 compared to a more common value of approx. 4-5. As a result, it is necessary to use 13 impeller stages to achieve the discharge pressure.

The train usually has two compressor casings, each with six or seven impeller stages but Hitachi designed a single casing compressor which applies the following technologies.

- (1) To maintain the required separation margin at the 2nd critical speed, the shaft was designed with optimized stiffness.
- (2) High efficiency was achieved by using a wedge type impeller developed by Hitachi.
- (3) Hitachi modified the rotor assembly work and dynamic balance work, to reduce the residual unbalance of the rotor.
- (4) Hitachi inspected the mechanical stability of the machine by carrying out an actual load and actual speed test (full load, full speed test) in our factory.

27 Picking System that Utilizes Compact Automatic Guided Vehicle

Hitachi released its newly developed compact automatic guided vehicle in September 2014.

The normal practice at a factory or warehouse is for the workers to move about on foot to pick parts, products, or other inventory from the shelves with reference to a list. The automatic guided vehicle travels to the designated location of the shelf containing the required parts or other products and brings the shelf to the worker instead of the worker doing this himself. This provides an approximate three-fold improvement in system-wide picking productivity because it allows the worker to concentrate on this task without having to move around.

The system also features other functions for improving materials handling efficiency, including locating shelves where they can be quickly retrieved based on frequency of use, or selecting a route that avoids congestion. Also, the installation cost is reduced by about 30%* of an automatic warehouse system that uses special-

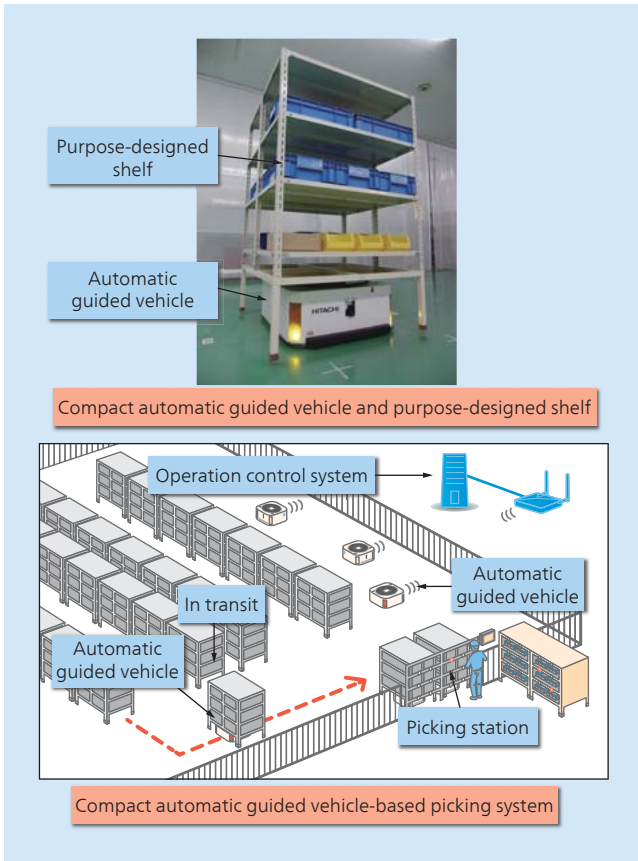

27 Picking system that utilizes compact automatic guided vehicle

purpose vehicles that can insert and remove parts or products on shelves entirely automatically.

In the future, Hitachi intends to market the product actively, overseas as well as in Japan.

* Compared to an automatic warehouse system supplied by Hitachi.

28 Supply Chain Change Management Service

Pharmaceutical manufacturers make ongoing additions and changes to things like their suppliers, manufacturing methods,

and sales channels with aims that include achieving sustained growth, reducing costs, and improving quality. One of the challenges facing global companies in particular and others with operations that span multiple regions is the requirement for numerous checks for the purposes of business practice consistency, legal compliance, and other matters relating to the revisions to business processes associated with these changes.

Recognizing that this challenge is one that applies to all manufacturers, not just those in the pharmaceutical sector, Hitachi is planning a service to support users in manufacturing utilizing the business know-how and information technology (IT) it has built up through consulting for manufacturers.

The service is intended to support complicated business activities by supplying, via a cloud environment, information (operation procedures, document formats, legal requirements, guidelines, etc.) that supports routine tasks and information that supports tasks that depend on know-how (past projects, past failures, analyses and predictions, etc.).

Through this service, Hitachi will help resolve problems that are shared across the manufacturing sector while also enabling individual companies to speed up their operations and improve quality (avoid problems and reduce risk).

(Service release date: FY2015)

29 Business Process Re-engineering

The following three points are among the challenges that are shared by global manufacturers.

- (1) Faster management decision-making through earlier identification of changes
- (2) Greater cost-competitiveness to take on global markets
- (3) Stronger governance for the effective improvement of group-wide profitability and competitiveness

The difficulties with overcoming these challenges include the broad scope of considerations, with inter-business coordination and the nature of the issues being complex, making it difficult to identify specific actions to take.

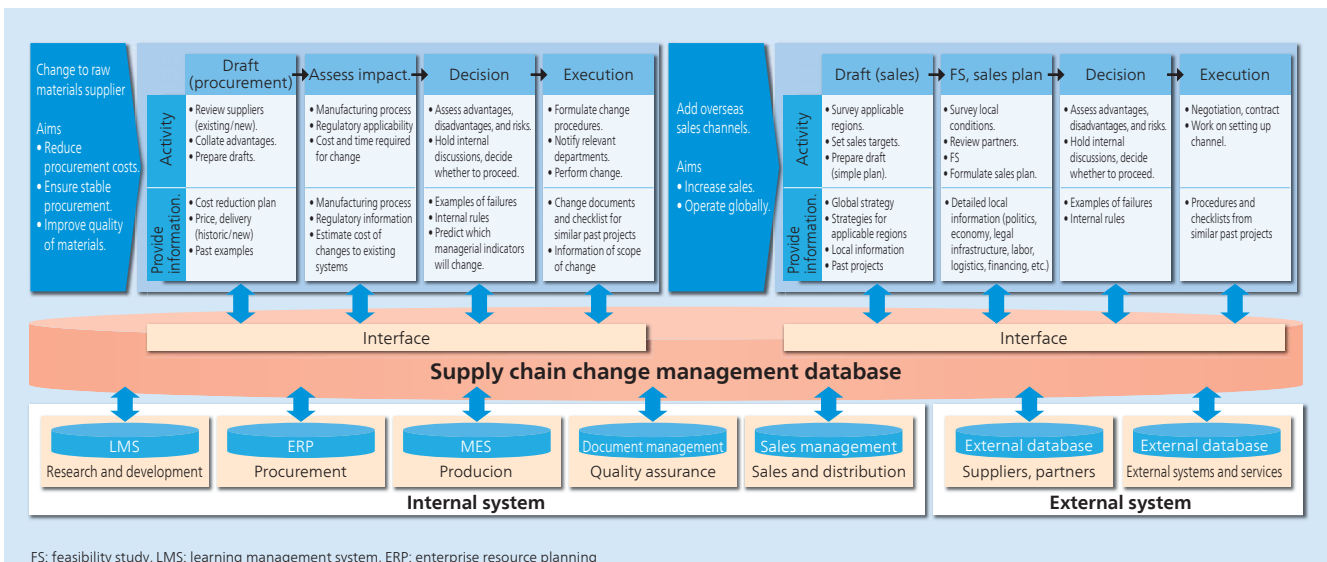

28 Supply chain change management service

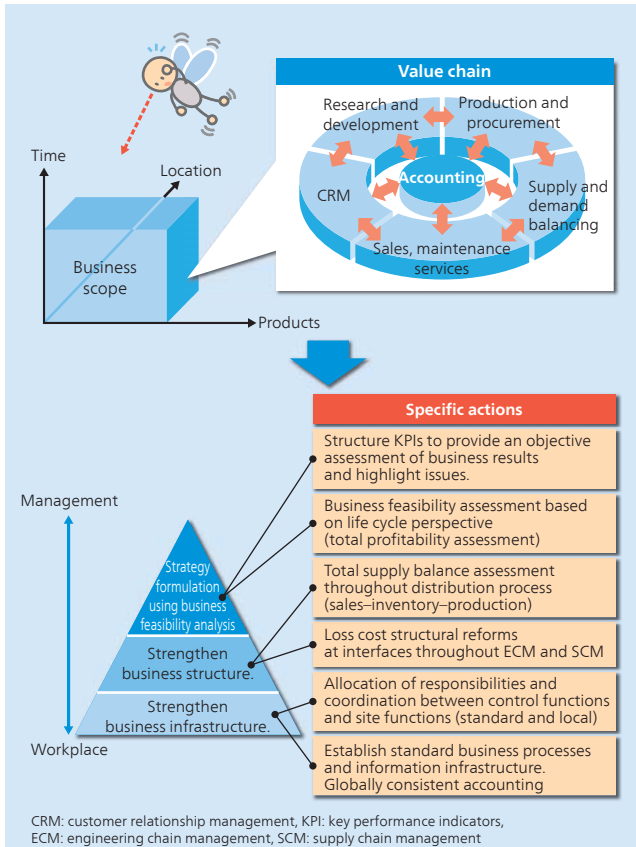

29 Example of key challenges for a manufacturer identified using the problem structure analysis method of business process re-engineering

Business process re-engineering is a methodology used by Hitachi to solve these difficulties. To resolve interrelated issues, it is necessary to take an objective bird's-eye view of the overall nature of the issues throughout the product supply value chain from research and development to sales and maintenance services, and to conduct a problem structure analysis. The method consists of consulting various different departments about the issues within the scope of the business being looked at (the scope may encompass the entire company, a factory, or supply chain reform, for example) to produce a single relational diagram that shows the problems throughout the scope, while also utilizing Hitachi's

know-how to identify latent issues.

To successfully implement pragmatic reforms, it is important to obtain an accurate understanding of how things stand from the current problem structure, and to establish a realistic action plan aimed at reaching the desired outcomes.

30 Production Line Simulator

With manufacturers facing an increasingly severe environment that includes the cost reductions needed for global price competitiveness, and with factories and other facilities being located throughout the world, challenges such as improving production efficiency and cutting transportation costs have become a concern. Since factory design in the past has mainly involved settings and assessments based on experience, resulting in cases where equipment was proven to be inadequate or in excess of the requirements after the factory commenced operation, an emphasis has come to be placed on the use of simulation to assess things like target production capacity in advance.

By simulating the flow of goods, the production line simulator can be used to devise production line configurations and production plans that achieve the target throughputs and lead times, and are also appropriate in terms of resources and cost. Also, the simulator makes it easy to model processes that correspond to various different production methods by selecting and setting up elements that represent assembly and materials handling processes, setup, and other tasks. These make it possible during the design of a new production line to shorten the time taken to confirm benefits, reduce actual costs and risks at the site, and make situation assessments that do not depend on the experience of the person making them in terms of operational aspects such as assessing plans in advance, making production predictions, and devising catch-up plans that take account of work in progress.

Drawing on its know-how as a manufacturer, Hitachi supports the production line design process and operation efficiency improvement process by using production line simulation techniques that improve production line efficiency from consulting to practical application.

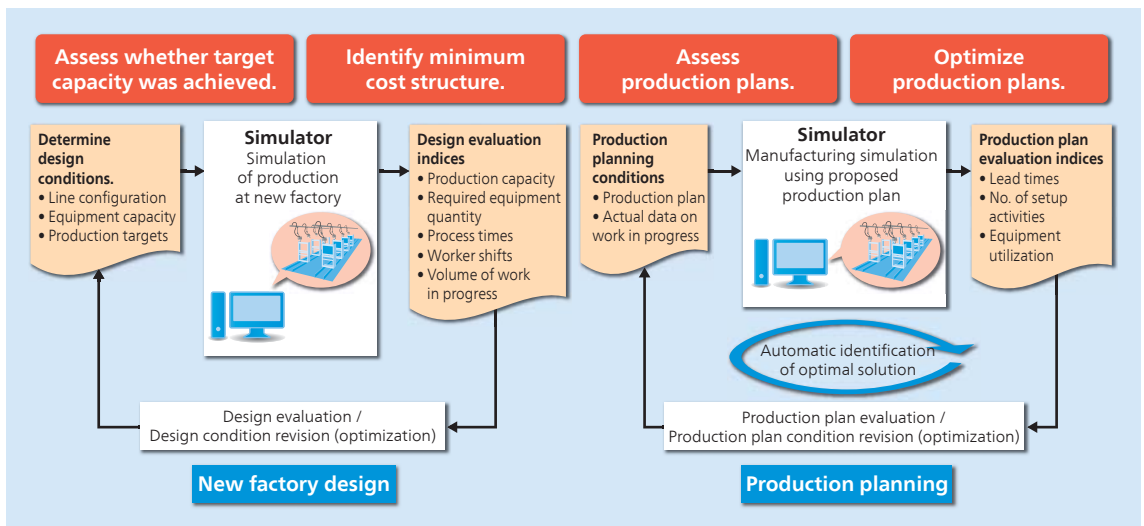

30 Example application of the production line simulator

Plant and Factory Equipment



1 Aluminum tandem hot rolling mill for CSAC of Taiwan

1 Aluminum Tandem Hot Rolling Mill for CSAC of Taiwan

An electrical control system for an aluminum tandem hot rolling mill supplied to the C.S. Aluminum Corporation (CSAC) of Taiwan* has commenced production and is operating reliably. The new mill was installed by CSAC downstream from an existing roughing mill with the aims of increasing production capacity and reducing production costs, with the first coil being produced only six months after Hitachi started electrical work. This contributed to an early commencement of production.

Hitachi developed mathematical models that can unify the rolling phenomena of a wide range of grades, from soft pure aluminum to hard alloy aluminum, and the system has achieved stable rolling and high strip thickness accuracy by optimizing the rolling force and roll gap, interstand tension, and other control commands. To reduce the workload associated with quality control, development, and maintenance after the plant commenced operation, Hitachi supplied a system with excellent ease-of-use and ease-of-maintenance that includes an integrated human-machine interface (HMI) that is used for operation and display by both the controllers and the information and control servers, and a network-connected 1-ms process data analysis (PDA) system that includes a coil-by-coil data collection and storage function.

* The first electrical control system for an aluminum tandem hot rolling mill (including installation) to be supplied by Hitachi outside Japan.

2 Use of New Controller for Steel Rolling Mills

Hitachi has supplied its newly developed controller for use in steel rolling mills.

In addition to combining eight circuit boards into one, including the three high-speed processing unit (HPUs) boards designed for control use that were used on the previous model, and having the capacity to install numerous modules using units, the newly developed controller uses HPU virtualization, which allows it to operate as if it had three separate HPUs. Along with a processing speed of 9.4 ns for bit instructions and support for the accelerated execution of large software, the control is also designed for improved reliability with the ability to duplex process input/output (PI/O) cabling. The new controller is also compatible with

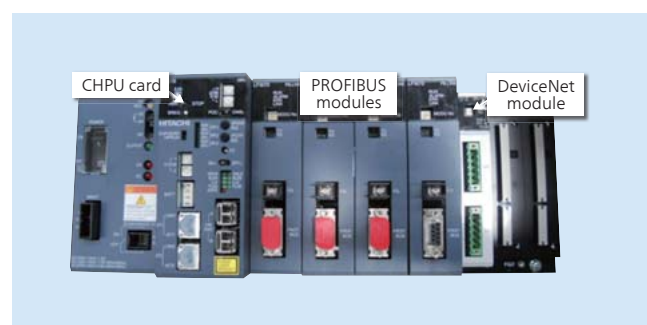

2 New controller

previous models in terms of both hardware and software, simplifying the re-use of PI/O and software.

It has already been installed and commissioned at a number of sites in Japan, with trial operation planned at overseas cold rolling mills and other plants.

3 Highly Accurate Strip Thickness and Tension Control System for Cold Rolling Mill

A problem that occurs when rolling thin strip at high speed on a single-stand rolling mill is long-period oscillations in the exit strip thickness (ranging from several seconds to ten or more seconds). This has made it difficult to combine the strip thickness accuracy required for product quality with the high-speed rolling needed to improve productivity. While Hitachi has dealt with this problem in the past by imposing constraints on the mechanical configuration, growing demand for high-speed rolling of products with tight product tolerances has resulted in cases where it has not been possible to meet the exit strip thickness accuracy requirements.

Now, Hitachi has conducted an analysis of the problems with conventional control techniques and has developed a highly accurate strip thickness and tension control system in which the strip thickness control and tension control used on the mill perform effective control of the roll gap and tension reel current based on actual rolling data. The control system suppresses the deviation of long-period oscillations in the exit strip thickness that occurred with conventional control techniques and improves exit strip thickness accuracy during high-speed rolling.

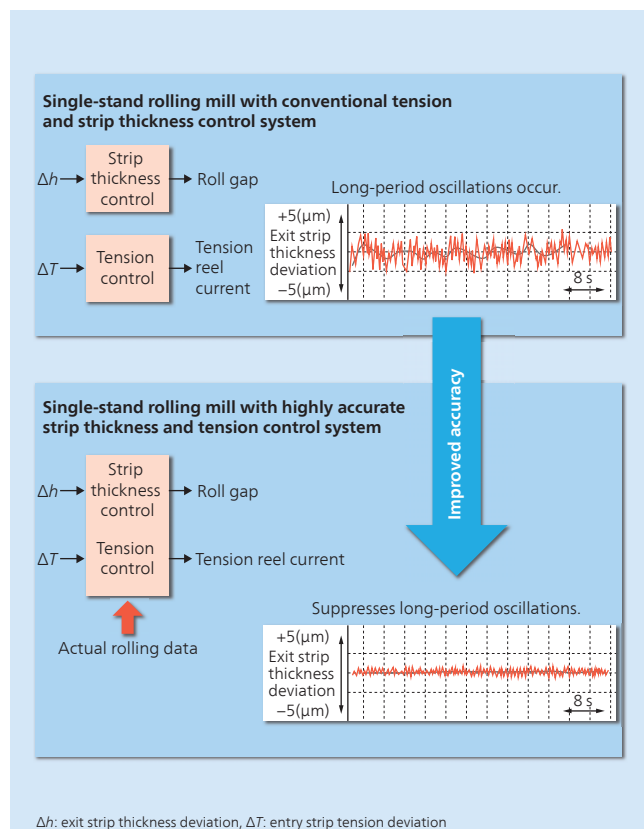

3 Highly accurate strip thickness and tension control system and its benefits

4 High-voltage, Large-capacity IGBT Inverter Drive System for Hot Rolling Mills (Second Generation)

Hitachi has supplied high-voltage, large-capacity insulated-gate bipolar transistor (IGBT) inverter drive system to new and existing hot rolling mills in Japan and elsewhere. To better satisfy the needs of users throughout the world, Hitachi has now developed a newly designed second-generation high-voltage, large-capacity IGBT inverter drive system. The system dimensions and range of available capacities have been completely revised.

The main features are as follows.

- (1) Achieves long-term product availability and large output capacity by adopting the global standard 3.3-kV/1.5-kA (3.0-kAp) IGBT devices and a more advanced technique for connecting the IGBTs in series.
- (2) Smaller system dimensions resulting from a simple circuit configuration. Panel width dimension is 50% less compared to similar conventional inverters (with 15-MVA capacity).
- (3) The main circuits can be connected together in parallel to offer a range of different capacities and supply drive systems that match user needs. The maximum capacity is 22.0 MVA (44.0 MVA in a two-bank configuration).

(Commencement of production: October 2014)



15.0-MVA converter/inverter

Parameter	Specification				
Circuit type	NPC three-level inverter				
Compatible motors	Three-terminal		Six-terminal		
No. of converter panels	1		1 × 2 banks		
No. of cell units in parallel	1	2	3	2 × 2	3 × 2
Rated output capacity (MVA)	8.0	15.0	22.0	30.0	44.0
Rated output voltage (Vrms)	4,500				
Cooling	Water-cooled (pure water)				
Overload specifications	150%/1 min				
Conversion efficiency	98% or higher (converter + inverter)				

NPC: neutral point clamped

4 Photograph and specifications of high-voltage, large-capacity IGBT inverter drive system for hot rolling mills (second generation)

5 HITPHAMS Installations in China

The HITPHAMS* (Hitachi pharmaceutical manufacturing execution system) is one of Japan's most widely used manufacturing execution system (MES) that is compliant with good manufacturing practice (GMP), and has been supplied to approximately 140 sites in Japan (as of September 2014).

In response to the 2010 revisions to China-GMP, China Food and Drug Administration (CFDA) has required all pharmaceutical manufacturers to introduce production procedures and associated records management by 2015. Anticipating an increase in demand for MES from the more than 6,000 pharmaceutical manufacturers in China, Hitachi established an engineering center in Beijing in 2013 with the aim of entering this market. To satisfy the needs of local companies, Hitachi is working with local partners on promotional and networking activities such as participating in trade shows and holding seminars.

The first HITPHAMS installation was successfully completed at the Chinese site of a Japanese company in 2013. Installation of HITPHAMS at major Chinese pharmaceutical manufacturer has also commenced, with the first system being installed in April 2014.

In the future, Hitachi intends to take full advantage of its successes with installing HITPHAMS and on its specialist know-how in validation consulting to contribute to high-quality pharmaceutical manufacturing by companies in Japan, China, and the rest of the world.

* HITPHAMS is a registered trademark of Hitachi, Ltd. in the United States, China and Japan.



5 Use of HITPHAMS at the site of a Japanese company in China

6 High-pressure Hydrogen Filling System for Hydrogen Stations

Measures aimed at creating a "hydrogen society" that makes full use of hydrogen as an energy source are accelerating. As a future basis for "secondary energy" (usable energy produced from other primary energy sources), hydrogen is characterized by having a low load on the environment, and work is proceeding with applications such as fuel cell vehicles. Now, Hitachi has supplied a high-pressure hydrogen filling system for hydrogen stations as part of its hydrogen distribution infrastructure business.

Consisting of a high-pressure, high-capacity compressor [45 MPa, 1,500 m³/h(Normal)], accumulator (4 m³), and dispenser, the supplied system enables the distribution of hydrogen to filling stations on a large scale using high-pressure hydrogen tanker trucks. Handling large quantities of hydrogen at high pressure requires pipework made of high-strength materials that are resistant to hydrogen embrittlement, and Hitachi has been striving to enhance existing techniques for installation work to improve safety.

In the future, Hitachi intends to contribute to the creation of a hydrogen society in a variety of ways, including through the supply of this system, for which demand is expected to grow as use of fuel cell vehicles becomes more widespread.



6 High-pressure, high-capacity compressor (top), accumulator (middle), and dispenser (bottom)



7 Factory testing of fuel removal and transportation crane for Unit 4 at Fukushima Daiichi Nuclear Power Station (the orange object is the spring shock absorber)

7 Crane for Fuel Removal and Transportation from Unit 4 at Fukushima Daiichi Nuclear Power Station

Hitachi has developed a crane (rated load: 100 t, crane span: 21.1 m) for the removal and transportation of spent fuel from Unit 4 at the Fukushima Daiichi Nuclear Power Station of Tokyo Electric Power Co., Inc.

The crane is located inside the new enclosure built around the reactor building (which has appeared from time to time in the Japanese media), where it is used to lift out steel casks that contain spent fuel and transport them out of the reactor building. A major feature of the crane is that it has been fitted with a large spring shock absorber that was designed specifically to minimize the effect of shocks to suspended casks that might occur during an earthquake. Hitachi worked with the spring manufacturer to conduct a series of design studies and verification tests to develop a new large spring shock absorber of a type never before used in an overhead crane.

The entire process from design to installation of a crane in a reactor building normally takes about five years. In this case, however, the people involved were galvanized by a strong sense of purpose, and together with cooperation from companies across the Hitachi Group, they succeeded in delivering the crane to the site in little more than a year, and had it in operation within a total elapsed time of less than two years.
(Hitachi Plant Mechanics Co., Ltd.)

8 Industrial LED Lighting

With demand over recent years for energy efficiency and electricity savings in all areas of society, the use of light-emitting diode (LED) lighting with low power consumption and long life is steadily growing in the home, and in retail, office, and other commercial buildings. There is also growing demand for the installation of LED lighting at industrial sites such as factories or

in overhead cranes. Demand is also forecast for the replacement market as restrictions on mercury vapor lighting imposed by the Minamata Convention on Mercury come into force in 2020. In order for LEDs to be used for industrial lighting, however, it is essential to minimize the negative effects on products of harsh environmental conditions that include vibration, shock, dust, and wide temperature variations.

To satisfy these requirements, Hitachi has been working on LED lighting that has excellent tolerance for such environments, and by making various design improvements, has succeeded in developing a new and highly reliable LED lights for industrial uses. The development included performance testing for vibration and shock (vibration: 0.5 G, shock: 5 G), dust tightness (IP6X protection rating), proofing against water immersion (IPX7), high temperatures and humidities [60°C, 95% relative humidity (RH)], heat cycle (−30°C to 60°C), and electrical noise tolerance [$1 \mu\text{s} \pm 1,500 \text{ V}$ during operation (in-house standard time) and $1 \mu\text{s} \pm 2,000 \text{ V}$ when not in operation (in-house standard time)]. This succeeded in developing lights that have a long design life of 60,000 hours.

(Hitachi Plant Mechanics Co., Ltd.)



8 Industrial LED lights installed on a crane